

# Camera Control Unit

## Operating Instructions

Before operating the unit, please read this manual thoroughly and retain it for future reference.

HDCU5000  
HDCU5500  
HDCU3500

---

# Table of Contents

<b>Overview</b> .....	<b>3</b>
System Configuration .....	4
<b>Location and Function of Parts</b> .....	<b>9</b>
Front Panel .....	9
HDCU5000 Rear Panel .....	11
HDCU5500/3500 Rear Panel .....	13
Option Kits .....	15
<b>Status Display</b> .....	<b>16</b>
Displaying the Status Screen .....	16
Status Display Screen .....	16
<b>Settings Using the Menu of the Unit</b> .....	<b>19</b>
Changing Menu Item Settings .....	19
<b>Settings Using the Web Menu</b> .....	<b>21</b>
Accessing the Web Menu .....	21
Web Browsers .....	21
Structure of the Web Menu .....	22
Name and Function of Settings/Information Display Area .....	23
CCU Information List Screen .....	24
<b>Menu Tree</b> .....	<b>25</b>
SYSTEM CONFIG Menu .....	25
VIDEO/MONITOR Menu .....	26
AUDIO/INTERCOM Menu .....	27
MAINTENANCE Menu .....	27
FILE Menu .....	27
NETWORK Menu .....	28
DIAGNOSIS Menu .....	29
<b>Menu List</b> .....	<b>30</b>
SYSTEM CONFIG Menu .....	30
Return Formats and Output Formats .....	48
VIDEO/MONITOR Menu .....	66
AUDIO/INTERCOM Menu .....	69
MAINTENANCE Menu .....	72
FILE Menu .....	74
NETWORK Menu .....	75
DIAGNOSIS Menu .....	82
<b>Appendix</b> .....	<b>84</b>
Precautions .....	84
Error Messages .....	84
<b>Specifications</b> .....	<b>85</b>
HDCU5000 .....	85
HDCU5500 .....	86
HDCU3500 .....	87
HKCU-FB50 .....	88
HKCU-SDI50 .....	89
HKCU-SFP50 .....	89
HKCU-SM50 .....	89

# Overview

The HDCU5000/5500 Camera Control Unit connects to an HDC5000/5500 Color Camera, via an optical fiber cable, and carries out signal processing, provides an interface with external equipment, and supplies power to the camera. The HDCU3500 Camera Control Unit connects to an HDC3500 Color Camera, HDC3100 Fiber Color Camera, or HDC2000-series<sup>1)</sup> HD Color Camera, via an optical fiber cable, and carries out signal processing, provides an interface with external equipment, and supplies power to the camera.

The unit is equipped as standard with a function for down-converting 4K signals (HDCU5000/5500 only) or HD signals<sup>2)</sup> to SD signals<sup>3)</sup> and a function for up-converting the image from another camera as the return video, which give the unit the flexibility to operate in 4K, HD, and SD camera systems.

The unit may be combined with an RCP-3000/1000 series Remote Control Panel (optional) to form a camera control system. In addition, by combining the unit with an MSU-1000/1500 Master Setup Unit (optional), you can form a system capable of controlling multiple cameras.

The unit can be mounted in a standard 19-inch EIA rack. The height is 3 units (use the RMM-301 Rack Mount Adaptor (option) for the HDCU5500/3500).

- 1) HDC2000 series: HDC2000/2580/2500/2400/1700
- 2) HD (high-definition) signals: Generic name for 1125-/750-line HDTV signals.
- 3) SD (standard-definition) signals: Generic name for NTSC/PAL signals, 525/625 component signals, and 525/625 composite signals.

\* Some models may not be available, depending on the country or region.

## Note

Before operating the system, check that the software and ROM versions of this unit and system configuration devices are compatible versions.

You can expand the functionality by installing the following option products.

*For details about installation of option products, contact a Sony service or sales representative.*

### **HKCU-FB50 UHB Transmission Board Kit (HDCU3500)**

Upgrades the unit to the equivalent of the HDCU5500.

### **HKCU-SDI50 12G-SDI Extension Kit (HDCU5000)**

Enables 12G-SDI output at 4K using a single system of four outputs.

### **HKCU-SFP50 ST 2110 Interface Kit (HDCU5000/5500/3500)**

Enables operation in an IP transmission system.

### **HKCU-SM50 Single Mode Fiber Connector Kit (HDCU5000/5500/3500)**

Enables connection with Sony cameras that support optical fiber transmission over a single-mode fiber cable. It can connect to HDC3500/3100 and HDC2000 series cameras.

\* The HDCE-100 Camera Extension Adaptor (option) is required for single-mode fiber connection.

### **HZCU-CNFG50 Config Control Software (HDCU5000/5500/3500)**

Enables configuration of the unit via the LAN-COM connector of the CCU using the EMBER+ protocol.

### **HZCU-SNMP50 SNMP Agent Software (HDCU5000/5500/3500)**

Enables remote monitoring via the LAN-COM connector of the CCU using the SNMP protocol.

### **HZCU-UHD35 4K/HDR Processor Software (HDCU5000/5500/3500)**

Enables conversion of HD signals transmitted from a camera to 4K signals.

\* Supported on the HDCU5000/5500 when the HKCU-SM50 is installed.

# System Configuration

## Note

Production of some of the peripherals and related devices shown in the figures may have been discontinued. For advice on choosing devices, please contact your Sony representative or dealer.

## HDCU5000/5500 connection example (optical fiber transmission)

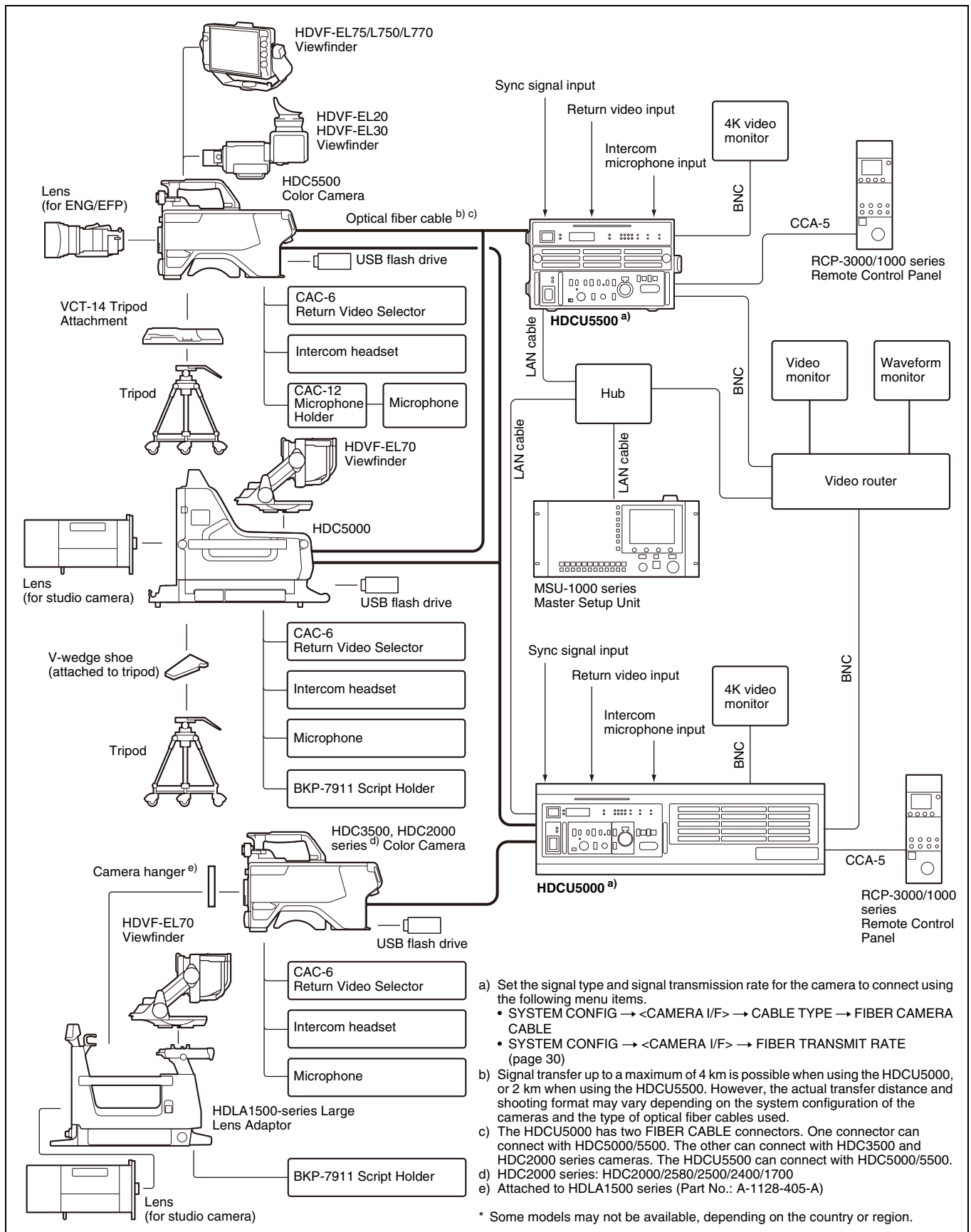

## HDCU3500 connection example (optical fiber transmission)

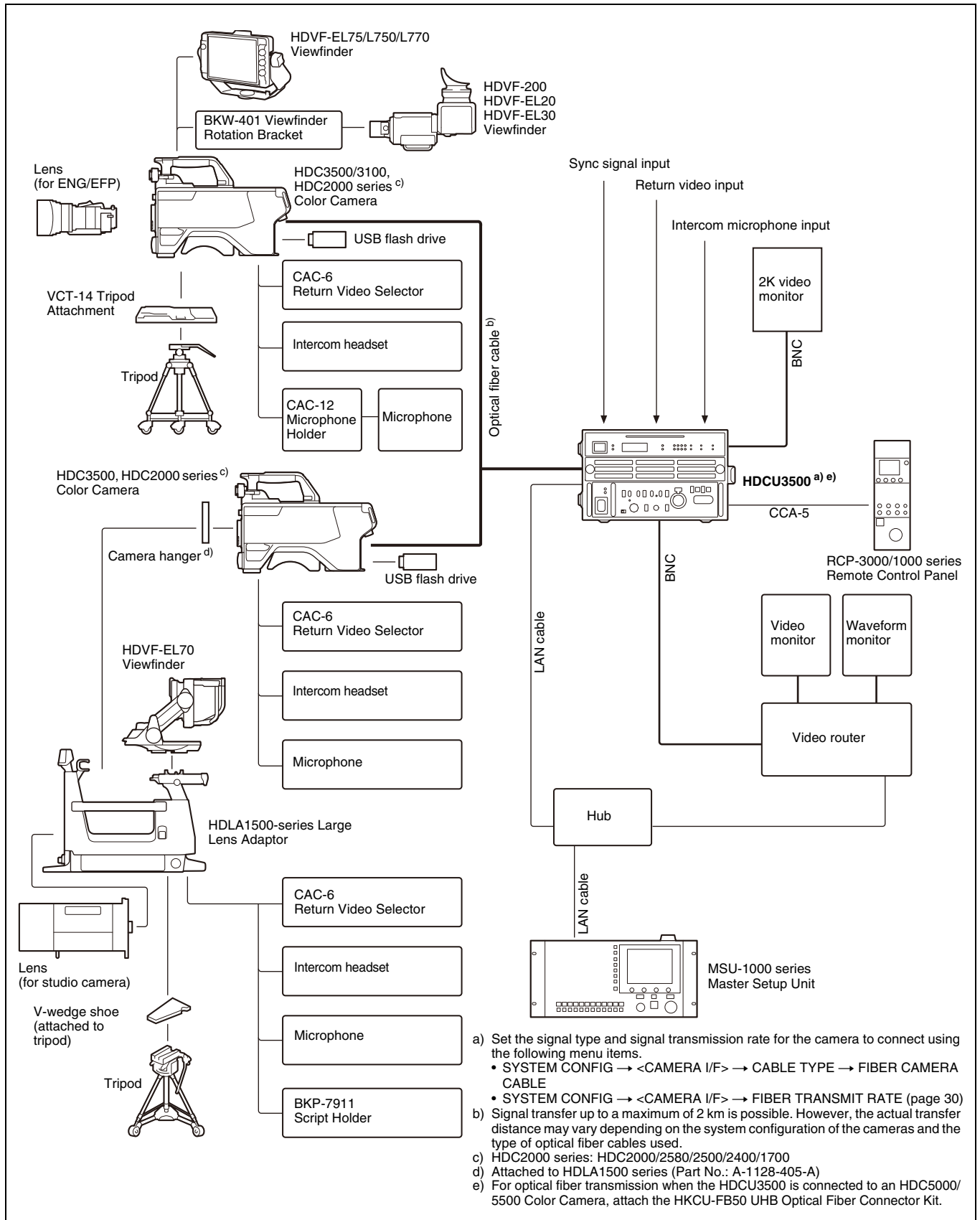

## Connection example (IP connection)

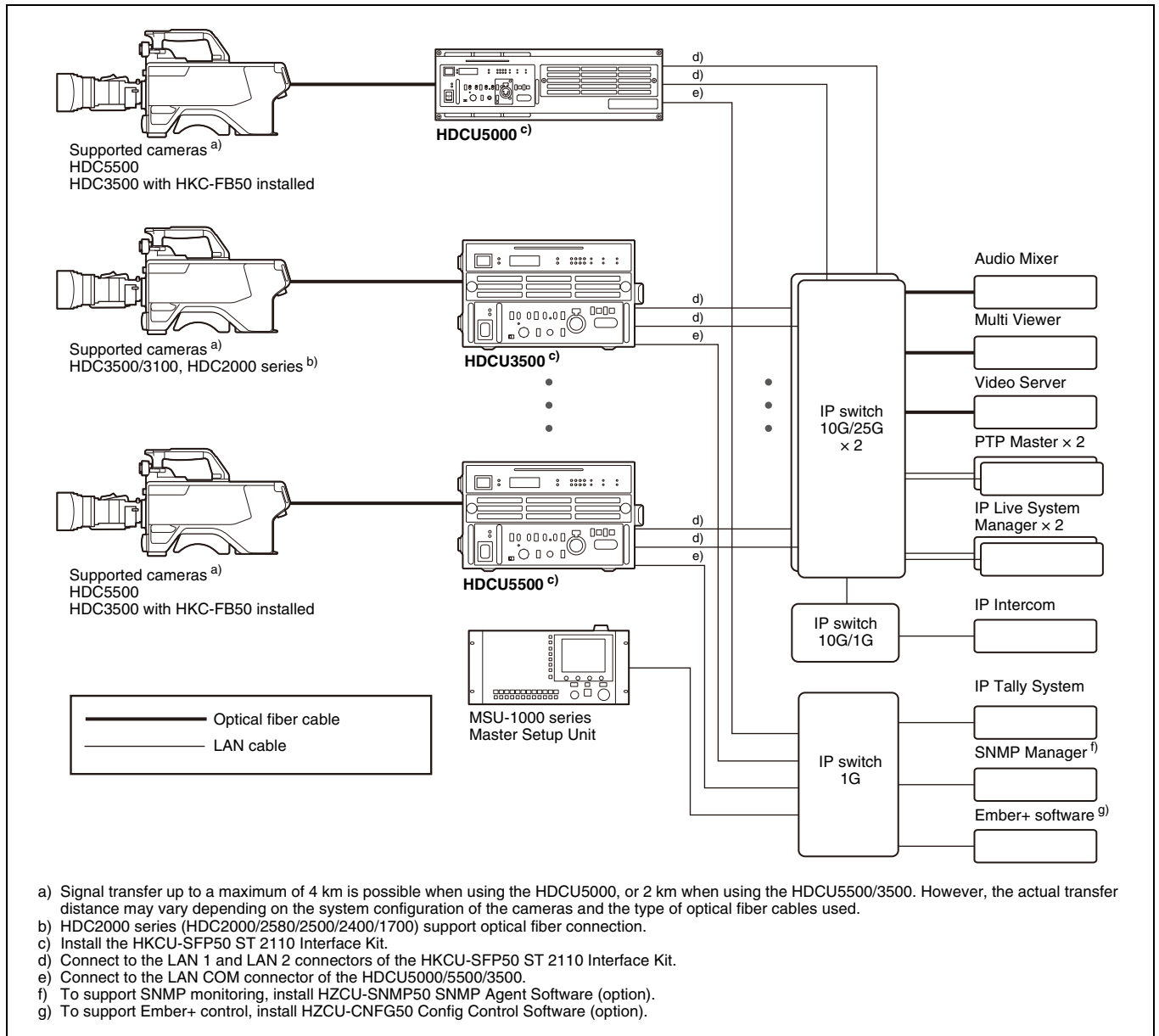

## Connection example (single-mode fiber connection)

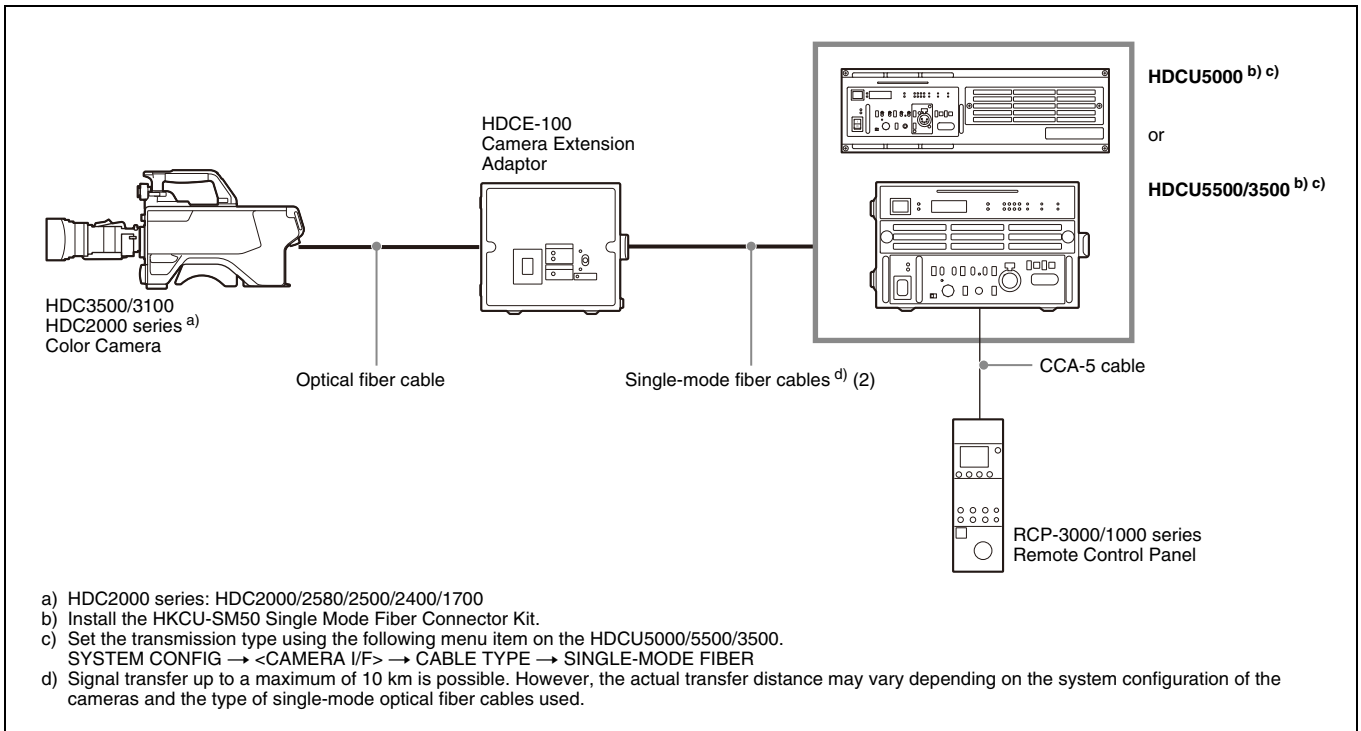

## Connection example (coax connection)

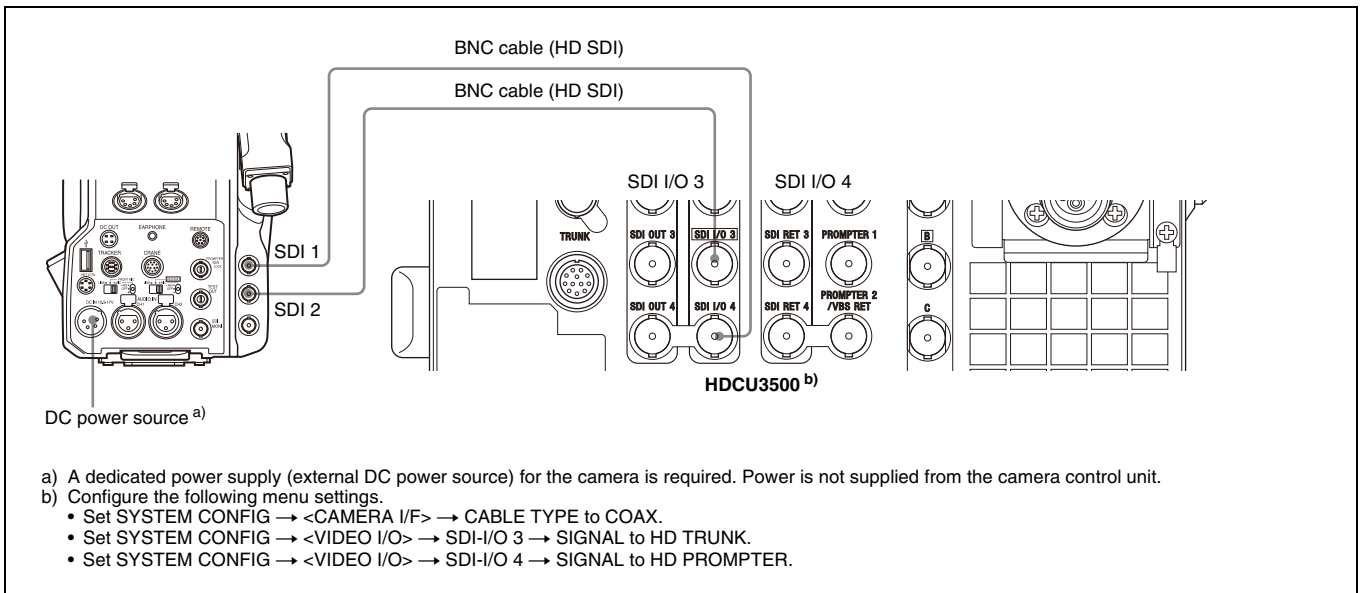

## Connection example (coax (HDCE) connection)

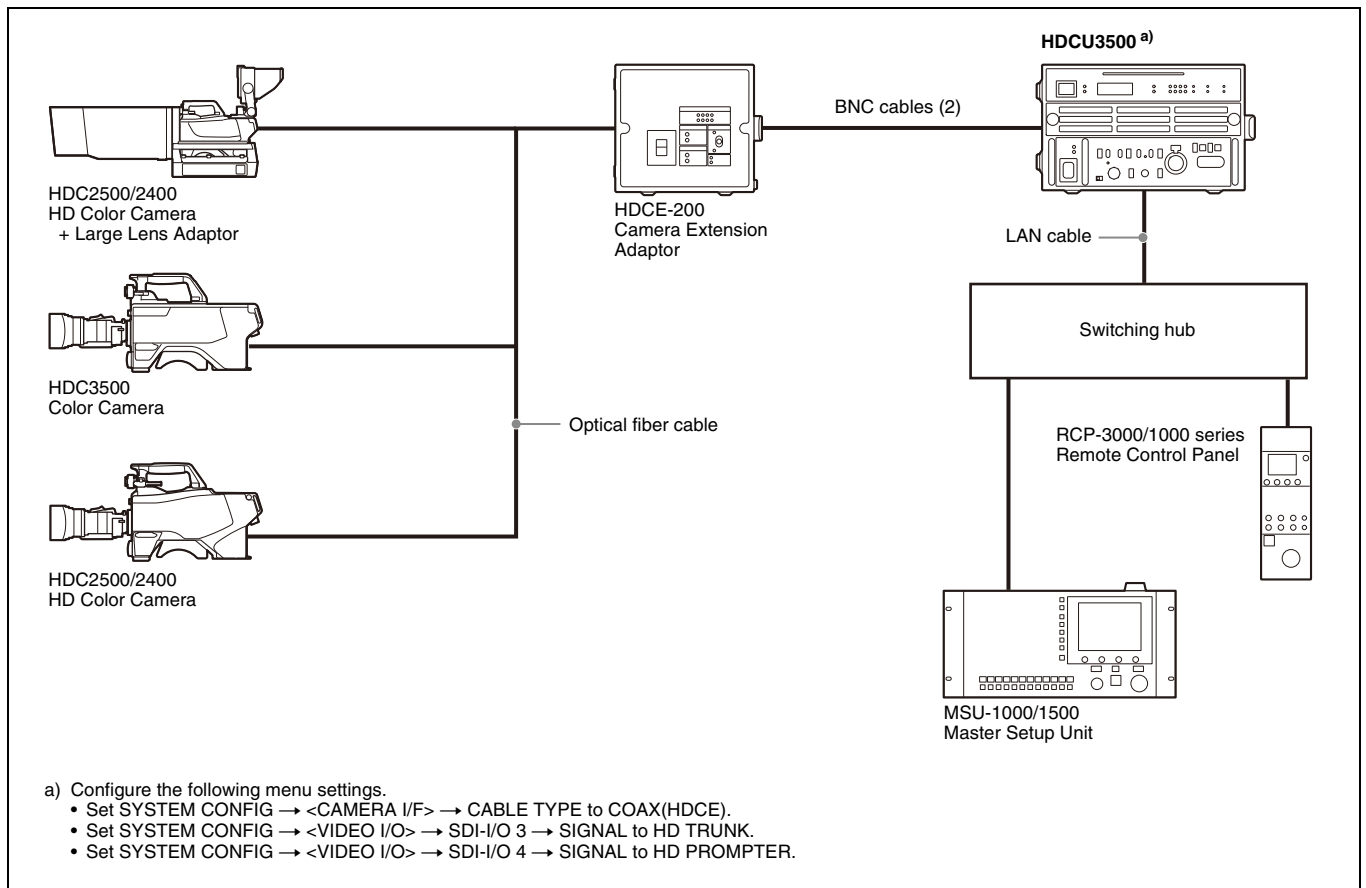



# Location and Function of Parts

## Front Panel

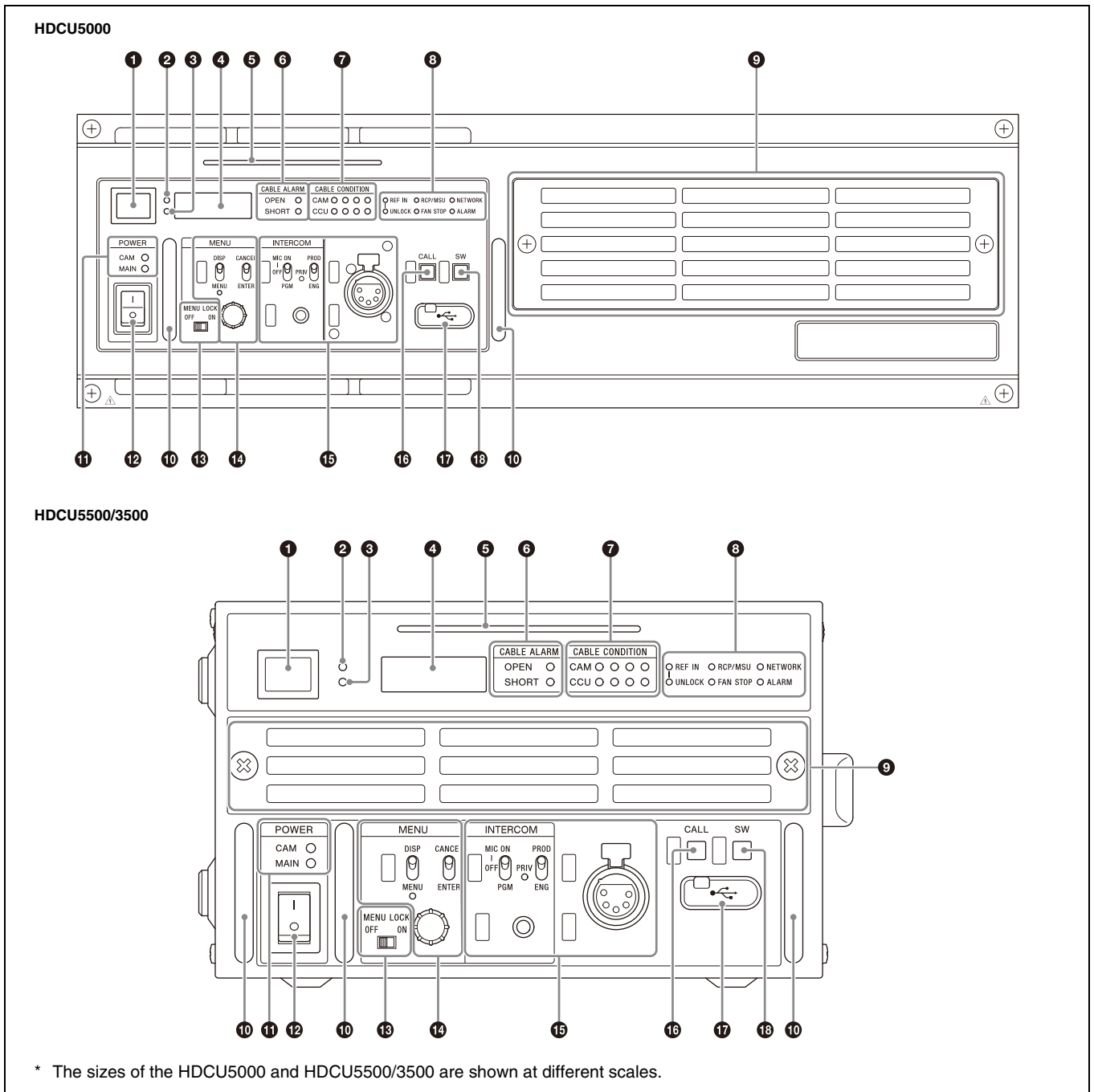

### 1 Red tally indicator

Lights in red when this unit receives a red tally signal. You can attach the supplied number plate here.

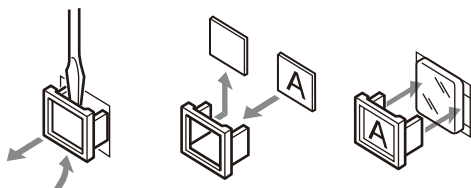

### 2 Yellow tally indicator

Lights in yellow when this unit receives a yellow tally signal.

### 3 Green tally indicator

Lights in green when this unit receives a green tally signal.

### 4 CCU number display

Displays the camera number set in the CCU menu. When the camera number is 0, the IP address and subnet mask of the LAN COM connector are displayed scrolling at regular intervals.

When the camera number is not 0, the IP address and subnet mask of the LAN COM connector are displayed scrolling for a fixed time only when the DISP/MENU lever is held up in the DISP position for 3 seconds.

### 5 SIGNAL BAR indicator

Indicates the output status of the video signal.

**During gray signal output:** Off

**During color bar output:** Lights in the color specified with the MAINTENANCE → <FRONT PANEL> → SIGNAL BAR → READY COLOR menu item.

**During camera video output:** Lights in a white flowing pattern.

### 6 CABLE ALARM indicators

**OPEN:** Lights up when a camera is not connected to the CAMERA FIBER connector on the rear panel of this unit via an optical fiber cable. Power is not supplied to the camera while this indicator is lit.

**SHORT:** Lights up when an overcurrent flows through the optical fiber cable. Power is not supplied to the camera while this indicator is lit.

### 7 CABLE CONDITION (signal reception status) indicators

Indicates the communication status of the camera (CAM) and camera control unit (CCU).

**When the two indicators on the right (green) are lit:** Reception status is excellent.

**When the second indicator from the right (green) is lit:** Reception status is good.

**When the second indicator from the left (yellow) is lit:** Reception status is low.

**When the indicator on the left (red) is lit:** Reception status is at the lowest level.

### 8 Status display indicator

**REF IN (green):** Indicates presence of REFERENCE input signal.

**UNLOCK (red):** Not locked to the REFERENCE input signal.

**RCP/MSU:** Displays the status when there is a remote control panel connected.

**On:** Indicates that external control equipment (MSU-1000/1500 Master Setup Unit, RCP-3000/1000 series Remote Control Panel, or other equipment) is connected.

**Off:** Indicates that external control equipment is not connected.

*For details, see "NETWORK Menu" (page 75).*

**NETWORK:** Displays the network genlock status when using the HKCU-SFP50 ST 2110 Interface Kit.

**Low-speed flashing:** PTP master not detected

**High-speed flashing:** Locking to PTP master

**Lit:** Locked to PTP master

**Not lit:** Network genlock setting disabled

**ALARM:** Lights when various errors occur.

**FAN STOP:** Lights when the fan is stopped.

### 9 Filter cover

Remove the screws on the left/right of the filter cover to remove the filter cover.

The filter (black sponge) is placed under the cover. If the filter becomes dirty, you can remove it and clean it with cold or warm water. When using a detergent, use a neutral solution.

Be sure to dry the filter thoroughly before replacing it on the unit.

### 10 Guard bar

#### Note

Do not pull the guard bar with excessive force.

### 11 POWER indicators

**CAM:** Lights when power is being supplied to the camera.

**MAIN:** Lights when the unit is turned on. In addition, this flashes when a fan error occurs.

### 12 POWER switch

Turns the entire camera system on and off, including the unit, the camera, and the RCP-3000/1000 series Remote Control Panel connected to the REMOTE connector of this unit. Switch to "I" to turn the power on, and switch to "O" to turn the power off.

### 13 Menu lock switch

Locks out operation of the front panel menu operation area.

### 14 MENU control block

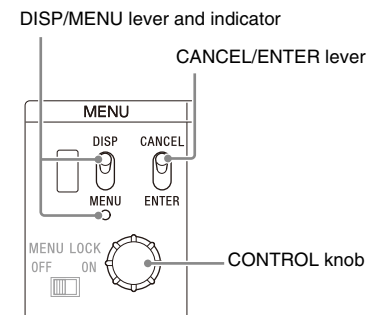

#### • DISP/MENU lever and indicator

Selects the status display or setup menu display. In setup menu mode, the indicator turns on.

When the camera number is not 0, the IP address and subnet mask of the LAN COM connector are displayed on the CCU number display scrolling for a fixed time only when the DISP/MENU lever is held up in the DISP position for 3 seconds. When <OUTPUT FORMAT1> → SDI-OUT4 → MONITOR is set to C, you can return to the M setting for MONITOR by holding the DISP/MENU lever down in the MENU position for 3 seconds.

#### • CANCEL/ENTER lever

In setup menu mode, used to cancel and enter settings.

#### • CONTROL knob (rotary encoder)

In status screen mode, used to change the displayed page. In setup menu mode, used to move the cursor on a page and to change menu settings.

Pushing the knob has the same function as setting the CANCEL/ENTER lever to ENTER.

## 15 INTERCOM audio input/output and control block

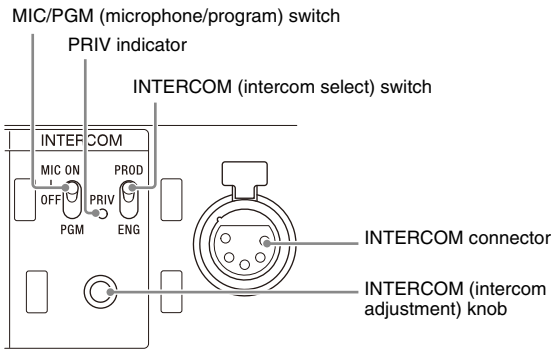

### • INTERCOM (intercom adjustment) knob

Adjusts the headset audio level.

### • MIC/PGM (microphone/program) switch

**ON:** Turns the headset microphone on.

**OFF:** Turns the headset microphone off.

**PGM:** Selects program audio output.

### • INTERCOM (intercom select) switch

Selects the intercom signal input/output connection source for the INTERCOM connector on the front panel.

**PROD:** Connects the producer line.

**PRIV:** Blocks the connection to the producer line or engineer line, allowing private intercom talk between the CCU and the camera.

**ENG:** Connects the engineer line.

### • PRIV (private) indicator

Lights when the intercom is in private mode.

### • INTERCOM connector (XLR 5-pin)

Connect the intercom headset.

## 16 Call button

When pressed, this outputs a call signal to the camera or external control devices (the RCP-3000/1000 series Remote Control Panel, etc.) that are connected to this unit. Use this when you want to call and speak with the camera operator or external control device operator via intercom. This button lights in red when it is pressed or the call button of other equipment is pressed.

## 17 USB port

Used to connect to a USB device.

## 18 Assignable button

You can set a function for this button via the CCU menu.

## HDCU5000 Rear Panel

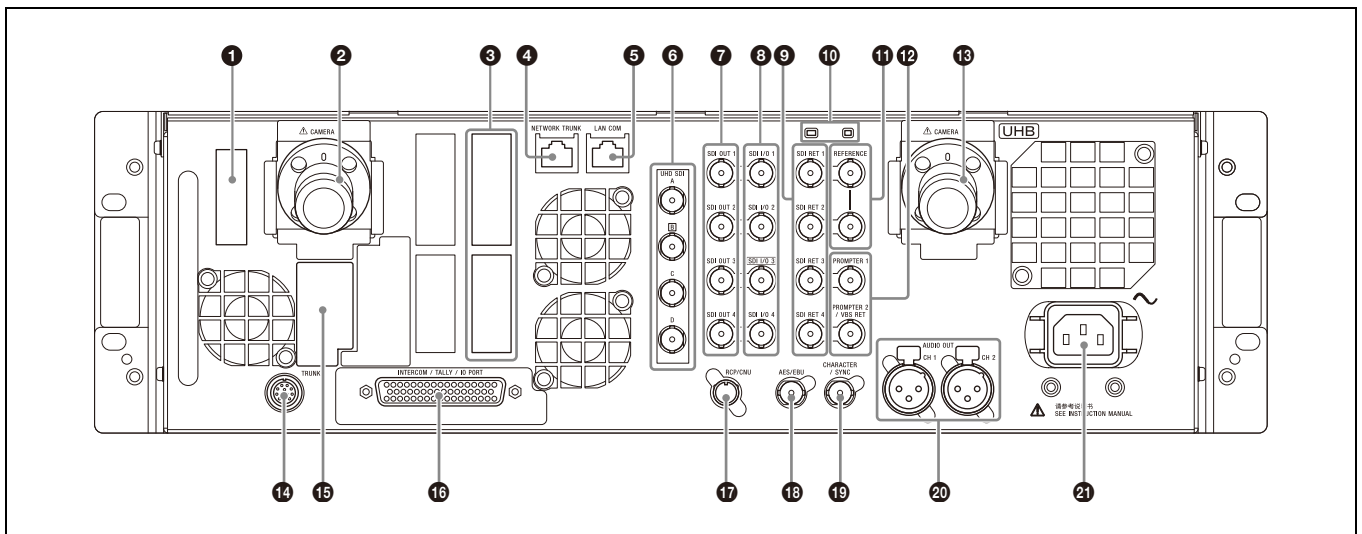

### 1 Option kit mounting port

The HKCU-SFP50 ST 2110 Interface Kit (option) can be installed. For an overview of option kits, see "Option Kits" (page 15).

### 2 CAMERA FIBER connector for HDC3500/3100 and HDC2000 series

Used to connect a video camera, using an optical fiber cable. All video camera signals, including power supply, control, video, and audio, are sent and received over one optical fiber cable.

#### Note

Dust on the connection surface of the optical fiber cable may result in transmission errors. When not connected, always cover the end of the connector with the supplied cap.

### 3 Option kit mounting port

Used to install HKCU-SDI50 12G-SDI Extension Kit. For an overview of option kits, see "Option Kits" (page 15).

### 4 NETWORK TRUNK connector (RJ-45 8-pin)

Used to connect the device connected to the NETWORK TRUNK connector of a camera with the network connection device.

### 5 LAN COM connector (RJ-45 8-pin)

Used to connect to a LAN. Connect a LAN hub (10BASE-T/100BASE-TX/1000BASE-T), using a LAN cable (shielded type of category 5 or higher).

## ⑥ UHD SDI A/B/C/D connectors (BNC-type)

The signal from the video camera is output as UHD (4K) SDI signals. The C and D connectors can also be used as input connectors.

*For details on settings, contact a Sony service or sales representative.*

## ⑦ SDI OUT (3G/HD/SD SDI output) 1/2/3/4 connectors (BNC-type)

The signal from the video camera may be output as 3G signals, HD-SDI signals, or SD-SDI signals. They can output signals with superimposed text characters and markers.

*For details on settings, contact a Sony service or sales representative.*

## ⑧ SDI I/O (3G/HD SDI input/output) 1/2/3/4 connectors (BNC-type)

These can be used as return video inputs, HD prompter inputs, camera video signal outputs, and HD-TRUNK outputs. Set them in NETWORK TRUNK on the <TRUNK/PROMPTER> page of the MAINTENANCE menu according to the application.

## ⑨ SDI RET (3G/HD/SD SDI return video input) 1/2/3/4 connectors (BNC-type)

Four different 3G/HD/SD SDI return video input signals may be received independently. The selection of RET 1 to 4 is made by the return switch of the video camera. The aspect ratio can also be selected for an SD signal. The type of input signal on RET 1 to 4 may be set individually using the setup menu, or using the MSU-1500 series Master Setup Unit.

*For details on the setup menu, contact a Sony service or sales representative.*

*Refer also to the Master Setup Unit manual.*

## ⑩ Rear indicator

Displays calls and statuses.

## ⑪ REFERENCE IN/OUT connectors (BNC-type)

Input an HD tri-level sync signal or SD reference signal (black burst signal, or black burst signal with 10-field ID) to the REFERENCE IN connector.

The input signal is output from the REFERENCE OUT connector as-is (loop-through). If loop-through output is not used, terminate the unused connector at 75 ohms.

## ⑫ INPUT area

### ① PROMPTER (tele-prompter input) 1/2 connectors (BNC-type)

Input the prompter signal of 1 channel or 2 channels depending on the setting of PROMPTER2/VBS-RET on the <REAR I/F> page of the SYSTEM CONFIG menu and PROMPTER CHANNEL MODE on the <TRUNK/PROMPTER> page of the MAINTENANCE menu. When PROMPTER/VBS-RET is set to DISABLE, the input signal is output from the other connector as-is (loop-through). If loop-through output is not used, terminate the unused connector at 75 ohms. When PROMPTER/VBS-RET is set to ENABLE, both connectors become inputs and they are terminated at 75 ohms inside the unit.

If the signal used is a 1.0 Vp-p, 75-ohm analog signal, it may be output from the PROMPTER OUT connector of the video camera with a frequency bandwidth of 5 MHz, regardless of signal format.

### Note

In the case of the HDC5500, connect to the PROMPTER1 connector. It is not supported by the PROMPTER2 connector.

### ② VBS-RET (VBS return video input) connector\* (BNC-type)

A single VBS return video signal can be input independently.

\* This connector doubles as the PROMPTER 2 connector.

The RET selection is made by the return switch of the video camera. The type of input signal on each RET connector may be set individually using the setup menu, or using the MSU-1000 series Master Setup Unit. The aspect ratio may also be selected for SD signals.

*For details on setup menu operations, contact a Sony service or sales representative.*

*Refer also to the Master Setup Unit manual.*

*For details on how to select the signal, contact a Sony service or sales representative.*

### ⑬ CAMERA FIBER connector for HDC5000/5500

Used to connect a video camera, using an optical fiber cable. All video camera signals, including power supply, control, video, and audio, are sent and received over one optical fiber cable.

### Note

Dust on the connection surface of the optical fiber cable may result in transmission errors. When not connected, always cover the end of the connector with the supplied cap.

### ⑭ TRUNK connector (round 12-pin)

Used to connect to the CCU connector on a camera via an RS-232C or RS-422A interface. Communication with up to two channels is available.

### ⑮ Option kit mounting port

The optional HKCU-SM50 Single Mode Fiber Connector Kit can be installed.

For an overview of option kits, see "Option Kits" (page 15).

### ⑯ INTERCOM/TALLY/IO (intercom / tally / input/output) connector (D-sub 50-pin)

Used to input and output intercom, tally, and program audio signals. Connect to the intercom/tally/program audio connector of the intercom system.

**REAR PREVIEW function:** Pin 35 is assigned for the output pin of the REAR PREVIEW function.

### ⑰ RCP/CNU connector (round 8-pin)

Used to connect to an MSU-1000 series Master Setup Unit, CNU-700 Camera Command Network Unit, or RCP-3000/1000 series Remote Control Panel via a CCA-5 connection cable. Control signals are sent and received via this connector. When using an RCP-3000/1000 series unit, power is also supplied.

**18 AES/EBU connector (BNC-type)**

Outputs the AES/EBU format digital audio signal that is input to the video camera.

**19 CHARACTER (character output) / SYNC connector (BNC-type)**

**CHARACTER:** Outputs the self-diagnostic results or setup menu of the unit as an SD analog video signal.

**SYNC:** Outputs an SD composite sync (without burst signal) or HD tri-level sync signal from the internal sync signal generator (default: SD composite sync signal).

*For details on how to select the signal, contact a Sony service or sales representative.*

**20 AUDIO OUT CH1, CH2 (audio output 1, 2) connectors (XLR 3-pin)**

Used to output the audio signal to the AUDIO IN connectors of the video camera.

**21 ~ AC IN (AC power input) connector**

Use the specified AC power cord to connect to an AC power supply. The AC power cord can be secured to this unit using the plug holder (optional).

**HDCU5500/3500 Rear Panel**

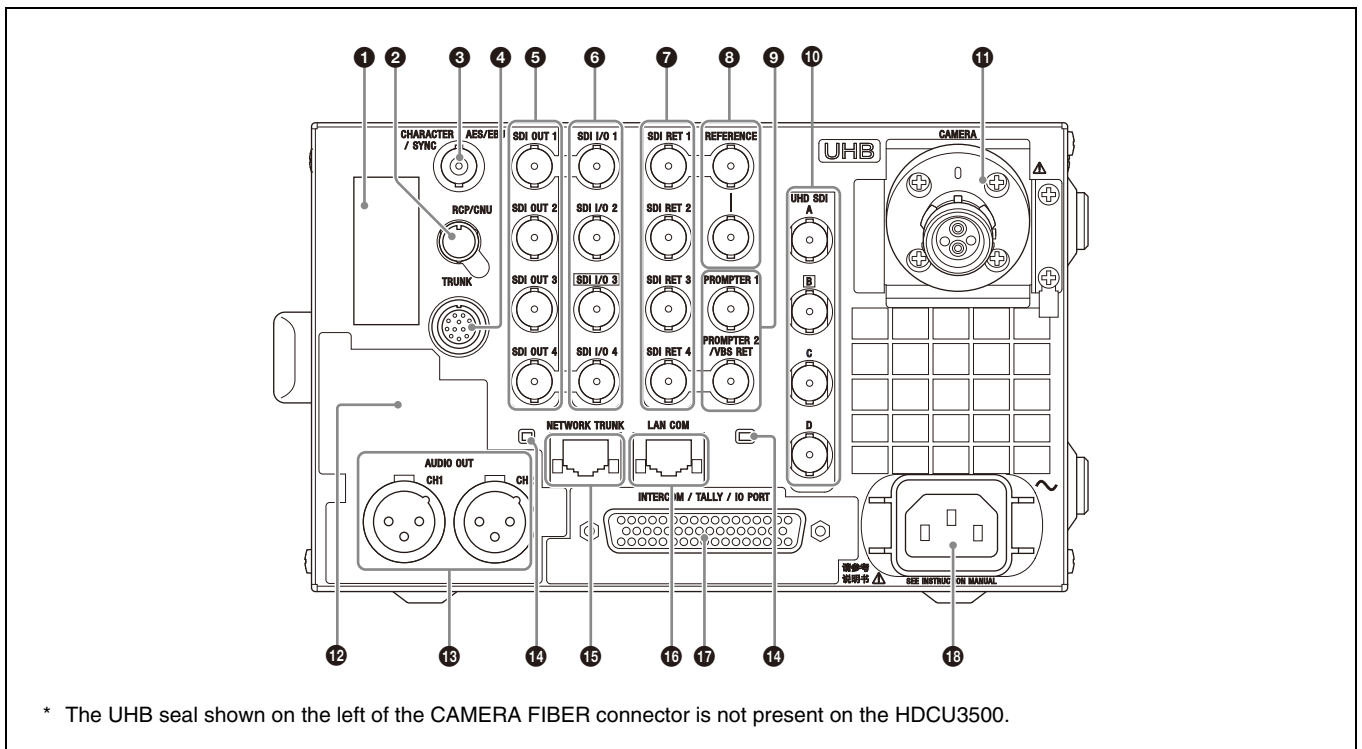

**1 Option kit mounting port**

The HKCU-SFP50 ST 2110 Interface Kit (option) can be installed. For an overview of option kits, see "Option Kits" (page 15).

**2 RCP/CNU connector (round 8-pin)**

Used to connect to an MSU-1000 series Master Setup Unit, CNU-700 Camera Command Network Unit, or RCP-3000/1000 series Remote Control Panel via a CCA-5 connection cable. Control signals are sent and received via this connector. When using an RCP-3000/1000 series unit, power is also supplied.

**3 CHARACTER (character output), AES/EBU, SYNC connector (BNC-type)**

**CHARACTER:** Outputs the self-diagnostic results or setup menu of the unit as an SD analog video signal.

**AES/EBU:** Outputs the AES/EBU format digital audio signal that is input to the video camera.

**SYNC:** Outputs an SD composite sync (without burst signal) or HD tri-level sync signal from the internal sync signal generator (default: SD composite sync signal).

*For details on how to select the signal, contact a Sony service or sales representative.*

**4 TRUNK connector (round 12-pin)**

Used to connect to the CCU connector on a camera via an RS-232C or RS-422A interface. Communication with up to two channels is available.

**5 SDI OUT (3G/HD/SD SDI output) 1/2/3/4 connectors (BNC-type)**

The signal from the video camera may be output as 3G signals, HD-SDI signals, or SD-SDI signals. They can output signals with superimposed text characters and markers.

*For details on settings, contact a Sony service or sales representative.*

## ⑥ SDI I/O (3G/HD SDI input/output) 1/2/3/4 connectors (BNC-type)

These can be used as return video inputs, HD prompter inputs, camera video signal outputs, and HD-TRUNK outputs. Set them in NETWORK TRUNK on the <TRUNK/PROMPTER> page of the MAINTENANCE menu according to the application.

## ⑦ SDI RET (3G/HD/SD SDI return video input) 1/2/3/4 connectors (BNC-type)

Four different 3G/HD/SD SDI return video input signals may be received independently. The selection of RET 1 to 4 is made by the return switch of the video camera. The aspect ratio can also be selected for an SD signal. The type of input signal on RET 1 to 4 may be set individually using the setup menu, or using the MSU-1500 series Master Setup Unit.

*For details on the setup menu, contact a Sony service or sales representative.*

*Refer also to the Master Setup Unit manual.*

## ⑧ REFERENCE IN/OUT connectors (BNC-type)

Input an HD tri-level sync signal or SD reference signal (black burst signal, or black burst signal with 10-field ID) to the REFERENCE IN connector.

The input signal is output from the REFERENCE OUT connector as-is (loop-through). If loop-through output is not used, terminate the unused connector at 75 ohms.

## ⑨ INPUT area

### ① PROMPTER (tele-prompter input) 1/2 connectors (BNC-type)

Input the prompter signal of 1 channel or 2 channels depending on the setting of PROMPTER2/VBS-RET on the <REAR I/F> page of the SYSTEM CONFIG menu and PROMPTER CHANNEL MODE on the <TRUNK/PROMPTER> page of the MAINTENANCE menu. When PROMPTER/VBS-RET is set to DISABLE, the input signal is output from the other connector as-is (loop-through). If loop-through output is not used, terminate the unused connector at 75 ohms. When PROMPTER/VBS-RET is set to ENABLE, both connectors become inputs and they are terminated at 75 ohms inside the unit.

If the signal used is a 1.0 Vp-p, 75-ohm analog signal, it may be output from the PROMPTER OUT connector of the video camera with a frequency bandwidth of 5 MHz, regardless of signal format.

#### Note

In the case of the HDC5500, connect to the PROMPTER1 connector. It is not supported by the PROMPTER2 connector.

### ② VBS-RET (VBS return video input) connector\* (BNC-type)

A single VBS return video signal can be input independently.

\* This connector doubles as the PROMPTER 2 connector.

The RET selection is made by the return switch of the video camera. The type of input signal on each RET connector may be set individually using the setup menu, or using the MSU-1000 series Master Setup Unit. The aspect ratio may also be selected for SD signals.

*For details on setup menu operations, contact a Sony service or sales representative.*

*Refer also to the Master Setup Unit manual.*

*For details on how to select the signal, contact a Sony service or sales representative.*

## ⑩ HDCU3500: UHD SDI A/B/C/D connectors (BNC-type)

The signal from the video camera is output as 3G/1.5G SDI signals.

If replaced with the HKCU-FB50 UHB Transmission Board Kit (option), the specifications become equivalent to the HDCU5500 and support UHD (4K) output.

When HZCU-UHD35 4K/HDR Processor Software (option) is installed, the signal from the video camera is output as a UHD (4K) SDI signal. The C and D connectors can also be used as input connectors.

*For details on settings, contact a Sony service or sales representative.*

## ⑩ HDCU5500, or HDCU3500 with HKCU-FB50 installed: UHD SDI A/B/C/D connectors (BNC-type)

The signal from the video camera is output as UHD (4K) SDI signals. The C and D connectors can also be used as input connectors.

*For details on settings, contact a Sony service or sales representative.*

## ⑪ CAMERA FIBER connector

Used to connect a video camera, using an optical fiber cable. All video camera signals, including power supply, control, video, and audio, are sent and received over one optical fiber cable.

#### Note

Dust on the connection surface of the optical fiber cable may result in transmission errors. When not connected, always cover the end of the connector with the supplied cap.

## ⑫ Option kit mounting port

The optional HKCU-SM50 Single Mode Fiber Connector Kit can be installed.

For an overview of option kits, see "Option Kits" (page 15).

## ⑬ AUDIO OUT CH1, CH2 (audio output 1, 2) connectors (XLR 3-pin)

Used to output the audio signal to the AUDIO IN connectors of the video camera.

## ⑭ Rear indicator

Displays calls and statuses.

## ⑮ NETWORK TRUNK connector (RJ-45 8-pin)

Used to connect the device connected to the NETWORK TRUNK connector of a camera with the network connection device.

## ⑯ LAN COM connector (RJ-45 8-pin)

Used to connect to a LAN. Connect a LAN hub (10BASE-T/100BASE-TX/1000BASE-T), using a LAN cable (shielded type of category 5 or higher).

**17 INTERCOM/TALLY/IO (intercom / tally / input/output) connector (D-sub 50-pin)**

Used to input and output intercom, tally, and program audio signals. Connect to the intercom/tally/program audio connector of the intercom system.

**REAR PREVIEW function:** Pin 35 is assigned for the output pin of the REAR PREVIEW function.

**18 ~ AC IN (AC power input) connector**

Use the specified AC power cord to connect to an AC power supply. The AC power cord can be secured to this unit using the plug holder (optional).

**Option Kits**

**Note**

For safety, only a qualified technician with service training should perform tasks inside the unit.

For details about installation, contact a Sony service or sales representative.

**HKCU-FB50 UHB Transmission Board Kit**

This unit is an option kit that replaces the 10 UHD SDI A/B/C/D connectors on the rear of the HDCU3500 and enables 4K transfer on the HDCU3500.

**Note**

HZCU-UHD35 4K/HDR Processor Software (option) is required for 4K output.

**HKCU-SDI50 12G-SDI Extension Kit**

This unit is an option kit that can be installed in the option kit mounting port 3 on the rear of the HDCU5000 Camera Control Unit and enables support for 1-system quad 12G-SDI output at 4K.

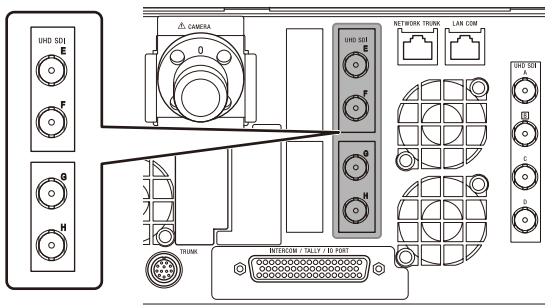

**HKCU-SFP50 ST 2110 Interface Kit**

This unit is an option kit that can be installed in the option kit mounting port 1 on the rear of the HDCU5000/5500/3500 Camera Control Unit and enables connection with SMPTE ST 2110 compliant devices.

**For HDCU5000**

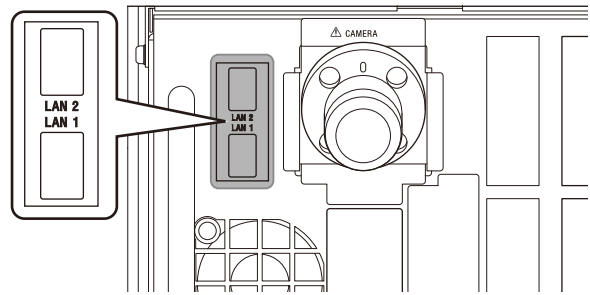

**For HDCU5500/3500**

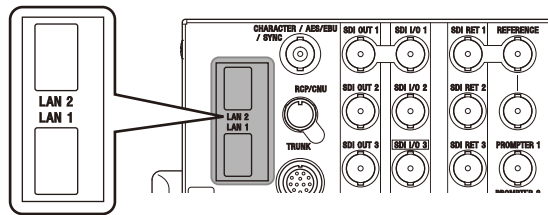

IP video signals and audio input/output, intercom, and network synchronization are performed using the LAN 1 and LAN 2 connectors (SFP+/SFP28). This enables one 4K and three HD IP inputs/outputs on the HDCU5000/5500/3500.

For RCP/MSU device connection and IP tally input, use the LAN COM connector.

The input/output signal format is set using <OUTPUT FORMAT IP> and <RETURN FORMAT IP> in the setup menu of the HDCU5000/5500/3500.

**Note**

An OTM-10GSR1 or other SFP+ module or SFP28 module is required to use IP output.

**HKCU-SM50 Single Mode Fiber Connector Kit**

This unit is an option kit that can be installed in the option kit mounting port 15 on the rear of the HDCU5000 Camera Control Unit or 12 on the rear of the HDCU5500/3500 Camera Control Unit, and enables single mode fiber transfer on the HDCU5000/5500/3500.

**Note**

It can only be used to connect with HDC3500/3100 and HDC2000-series cameras. It cannot be connected with the HDC5000/5500.

**For HDCU5000**

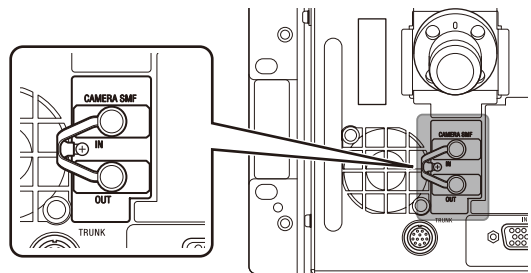



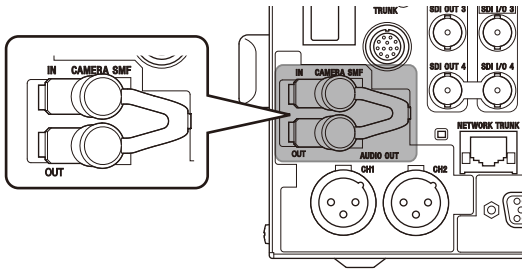

The CAMERA SMF IN connector inputs the video signal from the camera, audio (microphone) signal, HD-TRUNK signal, and NETWORK TRUNK signal.

The CAMERA SMF OUT connector outputs the return video signal to the camera, prompter video signal, program audio signal, and NETWORK TRUNK signal. The RS-422A and RS-232C interfaces are also supported.

**Note**

Dust on the connection surface of the connector may result in transmission errors. When not connected, always cover the end of the connector with a cap.

## Status Display

The CCU system status can be monitored using a video monitor connected to the CHARACTER, SDI OUT 3, or SDI OUT 4 connector.

**Note**

To use the SDI OUT 3 or SDI OUT 4 connector, set SYSTEM CONFIG → <OUTPUT FORMAT1> → SDI-OUT3 or SDI-OUT4 → MONITOR in the setup menu to M.

For information on monitoring and changing settings, see “Settings Using the Menu of the Unit” (page 19).

## Displaying the Status Screen

The menu screen is controlled using the knob and levers in the MENU control block on the front panel.

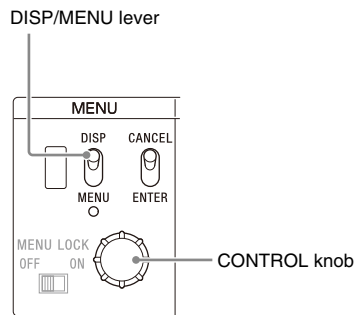

### To display the status screen

Set the DISP/MENU lever to the DISP position. The most recently viewed status screen page is displayed (when first powered on, the camera settings page is displayed). Turning the CONTROL knob changes the displayed page.

### To exit the status screen display

In status screen display mode, set the DISP/MENU lever to the DISP position.

## Status Display Screen

The following information is displayed on the status display screen.

- System status
- Input/output signal format information of each SDI connector
- Camera and unit audio status
- Camera and unit intercom status
- Warning display



## Camera settings

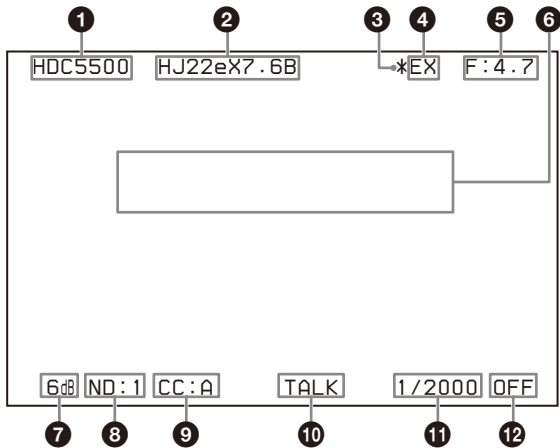

### 1 Camera name indication

Displays the name of the connected camera.

### 2 Lens file name indication

Displays the lens file name.

### 3 F drop indication

Displayed when an F drop occurs.

### 4 EX (lens extender) indication

Displayed during use of the lens extender.

### 5 F-stop value indication

Displays the lens F-stop value (iris value).

### 6 Camera auto control information area

**Top:** Displays the Auto Setup type and execution status.

**Bottom:** Displays the execution item.

### 7 Gain value indication

Displays the video output signal gain setting value (dB).

### 8 ND filter indication

Displays the currently selected ND filter type.

### 9 CC filter indication

Displays the currently selected CC filter type.

### 10 Camera microphone status indication

Displayed when the camera microphone is on.

### 11 Shutter speed/Clear scan frequency indication

Displays the shutter speed. When ECS is on, displays the clear scan frequency.

### 12 Shutter/ECS indication

Displays the on/off state of the shutter/ECS.

## Notes

- Items that are turned off using the <DISPLAY> page settings of the VIDEO/MONITOR menu are not displayed.
- A “-” mark is displayed for each item when a camera is not connected.

## System status

*System Status*		01/11
Camera Format	:	1080/59.94P
Camera Cable	:	Connected
Cable Type	:	Fiber Camera Cable
Power Supply	:	On
Cable Length	:	~100m
CAM		□□□□□■< OK
CCU		□□□□□■< OK
Reference	:	Not Detected Unlock
CCU No.	:	96
RCP/MSU	:	Connected

**Camera Format:** Signal format of connected camera

**Camera Cable:** Camera cable connection status

**Camera Type:** Camera cable type

**Power Supply:** Camera power supply status

**Cable Length:** Cable length

**CAM:** Camera light sensor level

**CCU:** Control unit light sensor level

**Reference:** Reference signal format used and genlock status  
 (“Not Detected” is displayed when a reference signal is not input.)

**CCU No.:** CCU number setting status

**RCP/MSU:** RCP/MSU connection status

## Input/output signal format status of SDI connectors

### SDI-OUT connectors

*Multi Format1*		02/11
SDI-OUT		
1:	1080/59.94P/36-A	
	OETF:HLG_BT.2100	Color:BT.2020
2:	1080/59.94P/36-A	
	OETF:HLG_BT.2100	Color:BT.2020
3:	1080/59.94P/36-A	
	OETF:HLG_BT.2100	Color:BT.2020
4:	1080/59.94P/36-A	
	OETF:HLG_BT.2100	Color:BT.2020

### SDI-I/O connectors

*Multi Format2*		03/11
SDI-I/O		
1:	1080/59.94P/36-A	
	OETF:HLG_BT.2100	Color:BT.2020
2:	1080/59.94P/36-A	
	OETF:HLG_BT.2100	Color:BT.2020
3:	(HD Trunk)	
4:	(Disable)	

## UHD-SDI connectors

```
*Multi Format3*                                04/11
UHD-SDI
A 3840x2160/59.94P/12G
OETF:HLG_BT2100 COLOR: BT2020
B 3840x2160/59.94P/12G
OETF:HLG_BT2100 COLOR: BT2020
C 3840x2160/59.94P/12G
OETF:HLG_BT2100 COLOR: BT2020
D 3840x2160/59.94P/12G
OETF:HLG_BT2100 COLOR: BT2020
```

Displayed only when HKCU-SDI50 is installed.

```
*Multi Format4*                                05/11
UHD-SDI
E 3840x2160/59.94P/12G
OETF:HLG_BT2100 COLOR: BT2020
F 3840x2160/59.94P/12G
OETF:HLG_BT2100 COLOR: BT2020
G 3840x2160/59.94P/12G
OETF:HLG_BT2100 COLOR: BT2020
H 3840x2160/59.94P/12G
OETF:HLG_BT2100 COLOR: BT2020
```

## IP-OUT connectors

Displayed only when HKCU-SFP50 is installed.

```
*Multi Format IP*                              06/11
IP-OUT
1:1080/59.94P/36-A
OETF:HLG_BT.2100 Color: BT.2020
SOURCE:CAMERA
2:M 1080/59.94P/36-A
OETF:HLG_BT.2100 Color: BT.2020
SOURCE:CAMERA
3:C 1080/59.94P/36-A
OETF:HLG_BT.2100 Color: BT.2020
SOURCE:HD TRUNK
```

## Camera and unit audio status

```
*Audio*                                         07/11
Camera
MIC Gain CH1 :60dB
           CH2 :60dB
CCU
AES/EBU Out :AES/EBU
Analog Out  :AES/EBU
```

**Camera MIC Gain CH1:** Camera microphone circuit 1 amp gain status

**Camera MIC Gain CH2:** Camera microphone circuit 2 amp gain status

**CCU AES/EBU Out:** Output format of the AES/EBU connector

**CCU Analog Out:** Output format of the analog output connector

## Camera and unit intercom status

```
*Intercom*                                     08/11
Camera
Engineer      :MIC On
Producer      :MIC Off
CCU
MIC/PGM       :MIC Off
Line          :System
```

**Camera Engineer:** Camera microphone status of the ENG line of the camera

**Camera Producer:** Camera microphone status of the PROD line of the camera

**CCU MIC/PGM:** Status of MIC/PGM switch on the front of the unit

**CCU Line:** Intercom system connection status

## Network status

Displayed only when HKCU-SFP50 is installed.

```
*Network*                                       09/11
LAN 1:Link Up          2:Link Up
SPD 1:25G              2:25G
FEC 1:RS-FEC          2:RS-FEC
LSM 1:Disconnected    2:Disconnected
PTP 1:Locked          2:Locked
Ref :1080/50I
      Locked
RDS :Connected
```

**LAN1:** Link status of the LAN1 connector

**SPD1:** Link speed of the LAN1 connector

**FEC1:** FEC setting for 25G of the LAN1 connector

**LSM1:** Connection status of the LAN1 connector with Live System Manager

**PTP1:** Network genlock status of the LAN1 connector

\* The above items are also shown for the LAN2 connector.

**Ref:** Used reference format setting and genlock status

**RDS:** Connection status with NMOS Registration & Discovery System

## IP stream status

Displayed only when HKCU-SFP50 is installed.

```
*IP Stream*                               10/11
OUT VIDEO1          IN RETURN1
  VIDEO2          RETURN2
  VIDEO3          RETURN3
  -----
          AUDIO          PGM
          HD TRUNK AUDIO
          INTERCOM          INTERCOM
          META1
          META2
          META3
          -----
```

Displays the stream status during IP transmission.

**OUT:** Outgoing IP stream

**IN:** Incoming IP stream

-----: No incoming/outgoing stream

## Warning display

```
*Alarm*                                   11/11
CCU:PS FAN STOP
CCU:GENLOCK ERROR
```

Displays any warning that occurs.

# Settings Using the Menu of the Unit

The CCU system and peripheral settings can be checked and modified using a video monitor connected to the CHARACTER, SDI OUT 3, or SDI OUT 4 connector.

### Note

To use the SDI OUT 3 or SDI OUT 4 connector, set SYSTEM CONFIG → <OUTPUT FORMAT1> → SDI-OUT3 or SDI-OUT4 → MONITOR in the setup menu to M.

## Changing Menu Item Settings

The menu screen is controlled using the knob and levers in the MENU control block on the front panel. Setting the CANCEL/ENTER lever to the ENTER position and pressing the CONTROL knob perform the same function.

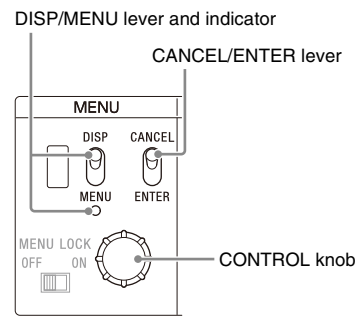

### To display a menu page

Set the DISP/MENU lever to the MENU position. When first powered on, the CCU MENU page is displayed. When <OUTPUT FORMAT1> → SDI-OUT4 → MONITOR is set to C (characters are not added), you can hold the DISP/MENU lever in the MENU position for 3 seconds to force display of the CCU MENU.

### To display the CCU MENU page

In menu display mode, turn the CONTROL knob to move the pointer (➡) to TOP in the upper right corner of the menu page, then press the CONTROL knob. The CCU MENU showing the menu configuration is displayed.

```
** CCU MENU **
→SYSTEM CONFIG
VIDEO/MONITOR
AUDIO/INTERCOM
MAINTENANCE
FILE
NETWORK
DIAGNOSIS
```

Menu name	Description
SYSTEM CONFIG	Input/output signal format and system-related settings
VIDEO/MONITOR	Video-related settings
AUDIO/INTERCOM	Audio- and intercom-related settings
MAINTENANCE	CCU configuration settings
FILE	CCU file-related settings
NETWORK	Network-related settings
DIAGNOSIS	Displays the unit status.

### To select an item in the CCU MENU

Turn the CONTROL knob to move the pointer (➡) up/down to the desired menu item, then press the CONTROL knob. The most recently viewed page in the selected menu is displayed.

### To change the displayed page

- 1 Turn the CONTROL knob to move the pointer (➡) to the page number, then press the CONTROL knob.

The pointer (➡) changes to a flashing question mark (?).

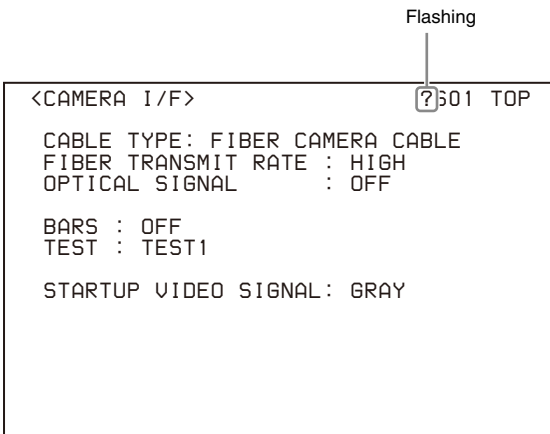

- 2 Turn the CONTROL knob to change the displayed page to the desired page, then press the CONTROL knob.

The question mark (?) changes back to the pointer (➡). Items on the page can now be selected and changed.

### To change a menu item setting

If a question mark (?) is displayed beside the page number, press the CONTROL knob to restore the pointer (➡). Items on the page can now be selected and changed.

- 1 Turn the CONTROL knob to move the pointer to the desired item, then press the CONTROL knob.
 

The pointer (➡) changes to a flashing question mark (?).
- 2 Turn the CONTROL knob to change the setting.

#### To cancel a changed setting

Set the CANCEL/ENTER lever to the CANCEL position before pressing the CONTROL knob. The item is restored to its current setting.

### To suspend menu changes

Set the DISP/MENU lever to the MENU position to exit the menu screen.

The DISP/MENU lever can be set to the MENU position again to restart the operation.

- 3 Press the CONTROL knob.

The question mark (?) changes back to the pointer (➡), and the item setting is registered.

- 4 Repeat steps 1 to 3 to change other settings on the same page.

### To enter a character string

Some menu items require a character string input.

Moving the pointer (➡) to an item with a character string input and pressing the CONTROL knob displays a rectangular cursor and a list of selectable characters.

Turning the CONTROL knob moves the cursor between characters. The following menu item has character strings:

- VIDEO/MONITOR menu → BAR CHARACTER page → BAR CHARACTER

- 1 Move the text cursor to the input position, then press the CONTROL knob.

A second cursor is displayed in the character list.

- 2 Turn the CONTROL knob to move the cursor to the desired character, then press the CONTROL knob.

Repeat steps 1 and 2 to enter other characters.

- Select INS to insert a space character at the cursor position.
- Select DEL to delete the character at the cursor position.
- Select RET to return to step 1 without changing the string.
- Entering the maximum number of characters (up to the right edge) moves the cursor to ESC on the lower right of the character list.

- 3 Turn the CONTROL knob to move the cursor to END, then press the CONTROL knob.

The new input string is registered.

### To cancel the character string setting

Turn the CONTROL knob to move the cursor to ESC, then press the CONTROL knob.

### To exit the menu display

In menu display mode, set the DISP/MENU lever to the MENU position.

# Settings Using the Web Menu

You can configure the unit, execute functions, and monitor settings information using the web menu. You can also monitor tally information and monitor the front panel information of the CCUs (camera control unit) connected to a private network on the same subnet as the unit. The web menu is accessed using a web browser on a PC.

## Note

Use of a monitor with resolution 1000x720 or higher is recommended to display the web menu normally.

## Accessing the Web Menu

- 1 Referring to the following connection example, connect a PC which has a web browser installed and the unit on the same private network.

## Note

The unit uses the multicast protocol for acquiring and updating information from other CCUs on the same subnet. Accordingly, use of a router that supports the IGMP Snooping function is recommended. If the IGMP Snooping function is not available, CCU information will be present on the network in the broadcasting state, increasing the load of devices on the same network. When <WEB MENU> → SERVICE DISCOVERY is set to OFF in the NETWORK menu, the multicast protocol is not used and only the information for the local unit is acquired and displayed.

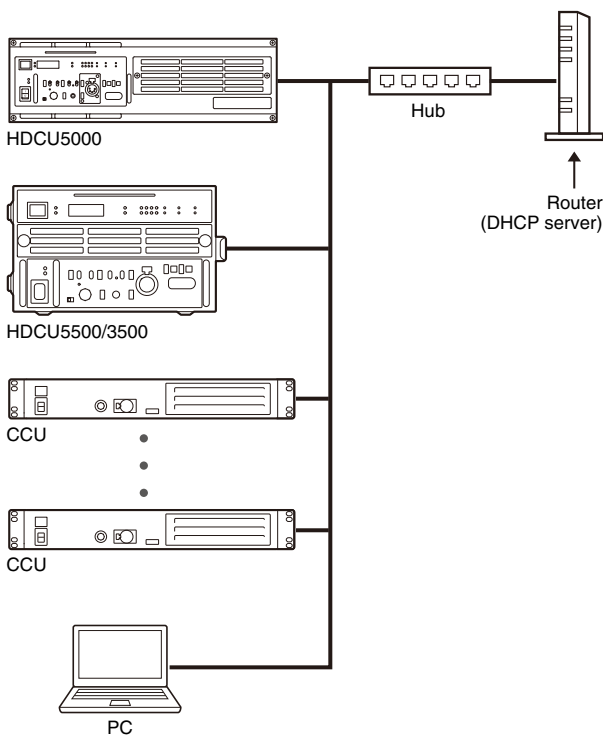

- 2 Check that the devices are turned on.

- 3 Check that <WEB MENU> → WEB MENU is set to ENABLE in the NETWORK menu.

- 4 Check the network settings of the unit using one of the following.

- In the setup menu of the unit (page 19), set <IP ADDRESS> → PORT to LAN-COM in the NETWORK menu to display the IP address of the unit and the subnet mask on the menu display.
- On the front panel of the unit, push and hold the DISP/MENU lever up in the DISP position for 3 seconds to display the IP address and subnet mask in the CCU number display area.

- 5 Enter the IP address of the unit in the web browser.

The web menu is accessed.

## Web Browsers

The use of Chrome is recommended. Use of a web browser other than Chrome may corrupt the layout of the web menu or may cause some functions to operate incorrectly.

# Structure of the Web Menu

The web menu is comprised by an area showing the settings and information of the unit and an area showing a list view of the information for other CCU units on the same subnet.

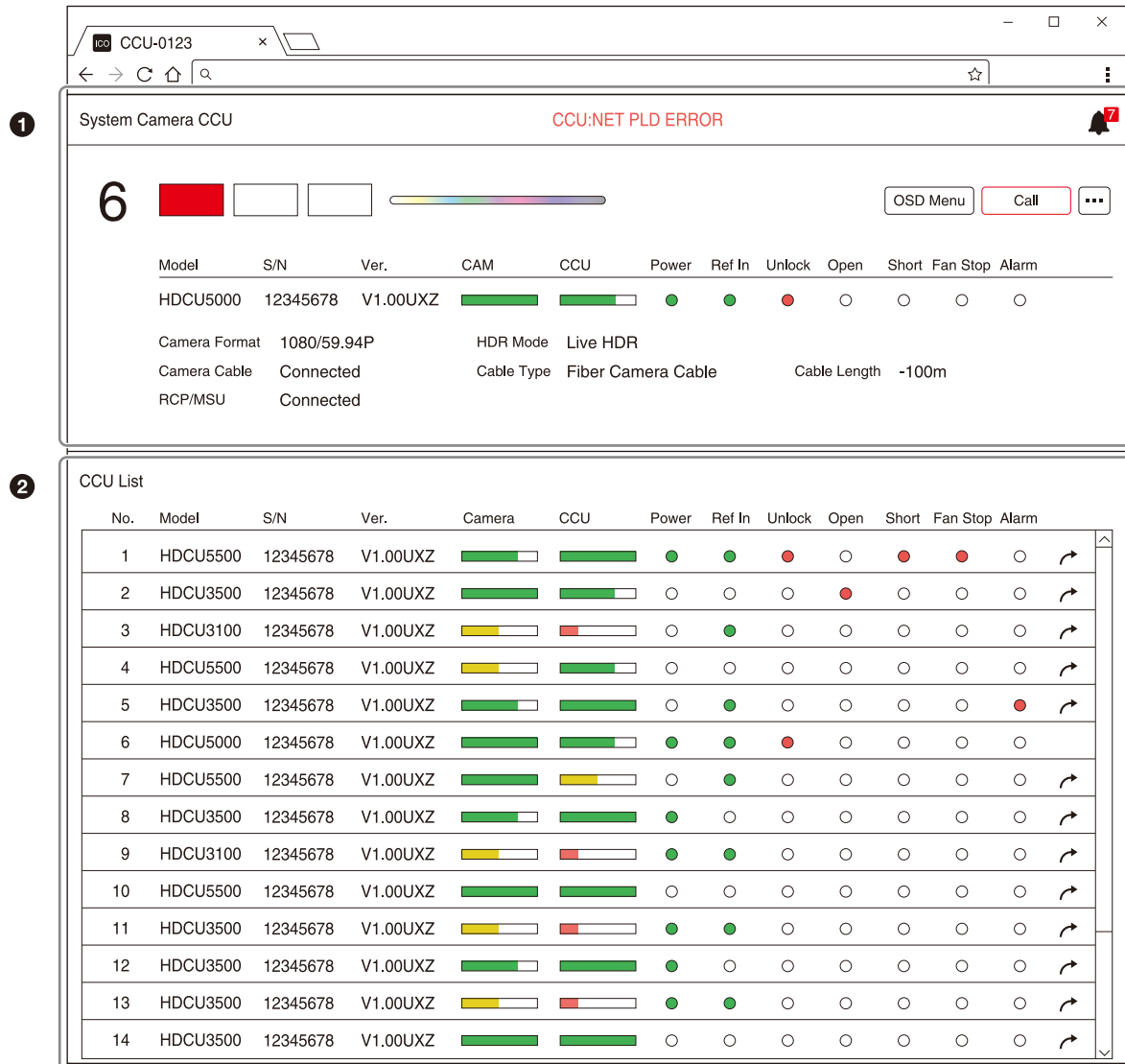

## 1 Unit settings/information display area

For details, see "Name and Function of Settings/Information Display Area" (page 23).

## 2 Information about CCU units on the same subnet

For details, see "CCU Information List Screen" (page 24).

### Notes

- The web menu actually displays white text on a dark gray background. The illustrations in this document show the colors reversed for increased clarity.
- Information for CCU units on another VLAN cannot be displayed.
- When the menu lock switch of the unit is in the ON position, the unit cannot be configured from the web menu.
- If the IP address is changed by direct operation on the unit or OSD operation in the web menu, a dialog displaying the changed IP address information appears in the web menu. Click the link in the dialog to reconnect to the unit using the new IP address and display the web menu again.

- If connection with a CCU being accessed using the web menu is lost for 30 seconds, a dialog appears and an attempt is made to reconnect. If 30 minutes elapse without reestablishing a connection, a dialog appears that prompts you to reload. If a connection is not reestablished in this dialog, the connection process is aborted and connection with the CCU is lost.

# Name and Function of Settings/Information Display Area

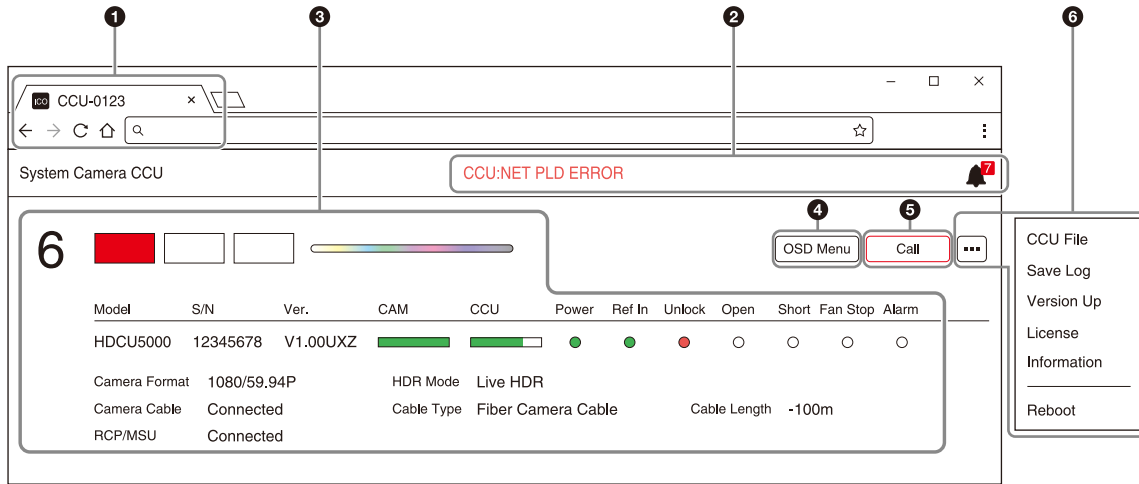

**Note**

When a setting of the unit is changed using the setup menu, the display in the web menu is also updated.

**1 Favicon / CCU number display**

Displays the favicon and CCU number in a tab.

**2 Error message display**

Displays the number of current errors at the top right of the icon. Click the icon to display the error messages in a pull-down list.

Error messages are also displayed in the center of the header. If there are multiple error messages, the error messages are displayed alternately at a set interval while they are blinking.

**3 Front panel information display**

Displays information about the front panel of the unit. The light sensor level of the camera and CCU are displayed in nine gradations of bar color and length.

Light sensor level	Bar display
High	(Bar color: green)
	(Bar color: green)
	(Bar color: green)
	(Bar color: green)
	(Bar color: yellow)
	(Bar color: yellow)
	(Bar color: red)
	(Bar color: red)
Low	(No bar display)

**4 OSD Menu button**

Click to display the OSD menu screen of the unit. The configuration items displayed on the OSD menu screen are the same as those displayed in the setup menu of the unit. You can switch between the OSD menu screen display and the status screen display of the status of the unit.

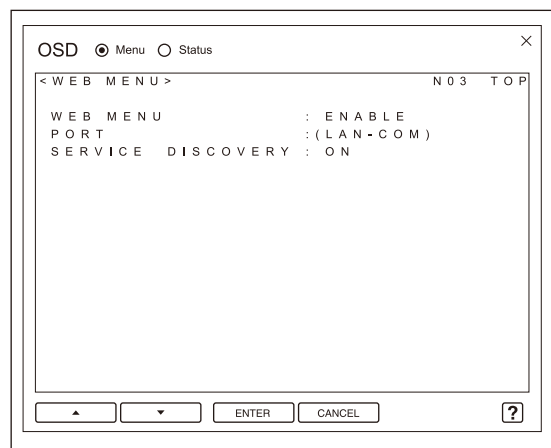

Click the  $\Delta$  (up) button and  $\nabla$  (down) button at the bottom of the screen to switch between screens. Clicking the ENTER button applies/executes a setting. Clicking the CANCEL button cancels a setting.

You can operate the unit using these buttons, the knobs and levers on the front panel, a mouse, or a keyboard.

OSD menu button	Front panel knob/lever	Mouse	Keyboard
$\Delta$ button	CONTROL knob	Scroll up	$\uparrow$
$\nabla$ button	CONTROL knob	Scroll down	$\downarrow$
ENTER button	CANCEL/ENTER lever	Left-click	$\rightarrow$
CANCEL button	CANCEL/ENTER lever	Right-click	$\leftarrow$

**Note**

When a setting of the unit is changed using the setup menu, the display in the OSD menu screen is also updated.

**Help screen**

Clicking the icon at the bottom right of the screen displays a help screen describing how to operate the OSD menu.

**5 Call button**

The call button of the unit lights up while the Call button is pressed using a mouse. Also, the display of the Call button on the screen changes to dark red while the Call button of the unit is pressed.

## 6 button

Click to display a context menu containing a list of the functions that can be executed from the web menu.

**CCU File:** Executes the same functions as on the <CCU FILE> page of the FILE menu of the unit. You can upload a CCU file stored on a PC to the unit, or download a CCU file from the unit to a PC.

**Save Log:** Downloads the log file (log.zip) of the unit.

**Version Up:** Store the package file on the PC used to access the web menu before updating the unit using this function. During the update process, a screen indicating that the unit is updating appears in the web menu. When the update is completed, the unit restarts automatically and the web menu connects again automatically.

**License:** Downloads the device information file (DEVICE.DAT) required for license authentication to a PC via the web menu. It can also perform the following operations which are equivalent to functions on the <OPTION> page of the MAINTENANCE menu.

- ① Install license key (USB flash drive not required)
- ② Check the status of software licenses

**Information:** Displays software license information (equivalent to the <OPTION> page of the MAINTENANCE menu), version information (equivalent to the <VERSION> page of the DIAGNOSIS menu), and camera diagnosis information (equivalent to the <CAMERA DIAGNOSIS> page of the DIAGNOSIS menu).

**Reboot:** Reboots the unit.

## CCU Information List Screen

This screen displays information about CCU units on the same subnet in list view sorted by CCU number. To display the CCU information list, set <WEB MENU> → SERVICE DISCOVERY to ON in the NETWORK menu.

Currently accessed CCU

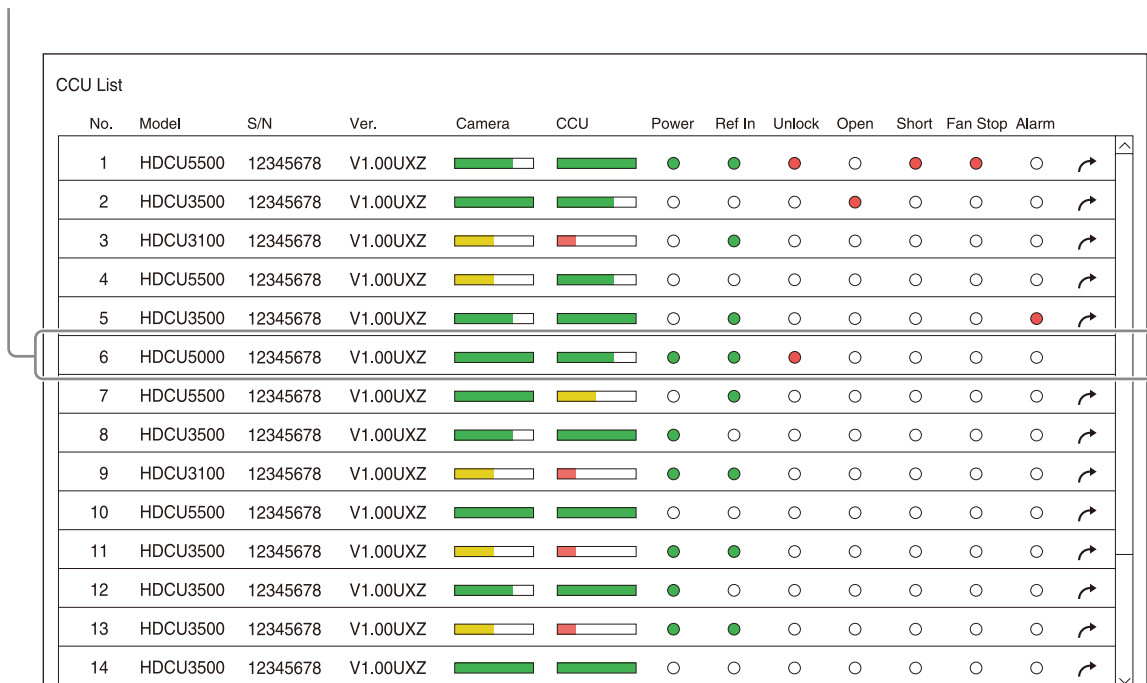

No.	Model	S/N	Ver.	Camera	CCU	Power	Ref In	Unlock	Open	Short	Fan Stop	Alarm	
1	HDCU5500	12345678	V1.00UXZ										
2	HDCU3500	12345678	V1.00UXZ										
3	HDCU3100	12345678	V1.00UXZ										
4	HDCU5500	12345678	V1.00UXZ										
5	HDCU3500	12345678	V1.00UXZ										
6	HDCU5000	12345678	V1.00UXZ										
7	HDCU5500	12345678	V1.00UXZ										
8	HDCU3500	12345678	V1.00UXZ										
9	HDCU3100	12345678	V1.00UXZ										
10	HDCU5500	12345678	V1.00UXZ										
11	HDCU3500	12345678	V1.00UXZ										
12	HDCU3500	12345678	V1.00UXZ										
13	HDCU3500	12345678	V1.00UXZ										
14	HDCU3500	12345678	V1.00UXZ										

### Notes

- The information displayed in the CCU information list is acquired via the network. There may be a short delay before the information is reflected on the screen compared to the settings/information display area.
- If communication from a CCU is not received for 30 seconds, the corresponding CCU row becomes gray. When updated information is detected, the background color returns to normal.
- When the setting of a CCU displayed in the list changes, the display of the list is updated.
- Models supported by the CCU information list display are HDCU3100 V2.2 and later, HDCU3170 V2.2 and later, and HDCU5000/5500/3500 V1.0 and later.

The front panel information of each CCU is displayed on each row. You can switch to the web menu of a CCU by clicking the  button.

The  button is not displayed in the row of the currently accessed CCU. The background color also differs from the other rows.



# Menu Tree

## SYSTEM CONFIG Menu

Menu items marked "1)" are displayed only for HDCU5000/5500 or HDCU3500 (with HZCU-UHD35 installed).  
Menu items marked "2)" are displayed only when HKCU-SFP50 is installed.

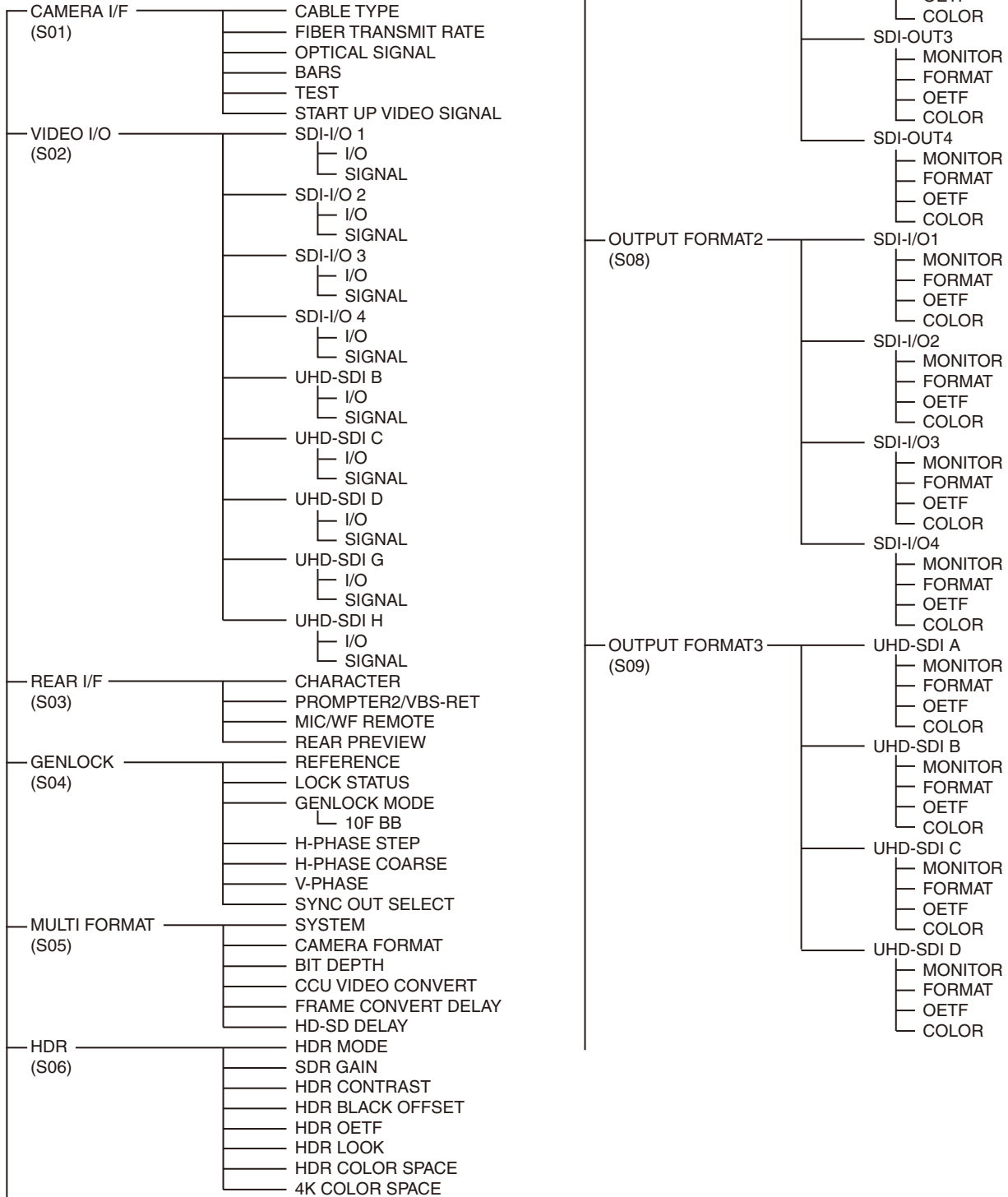

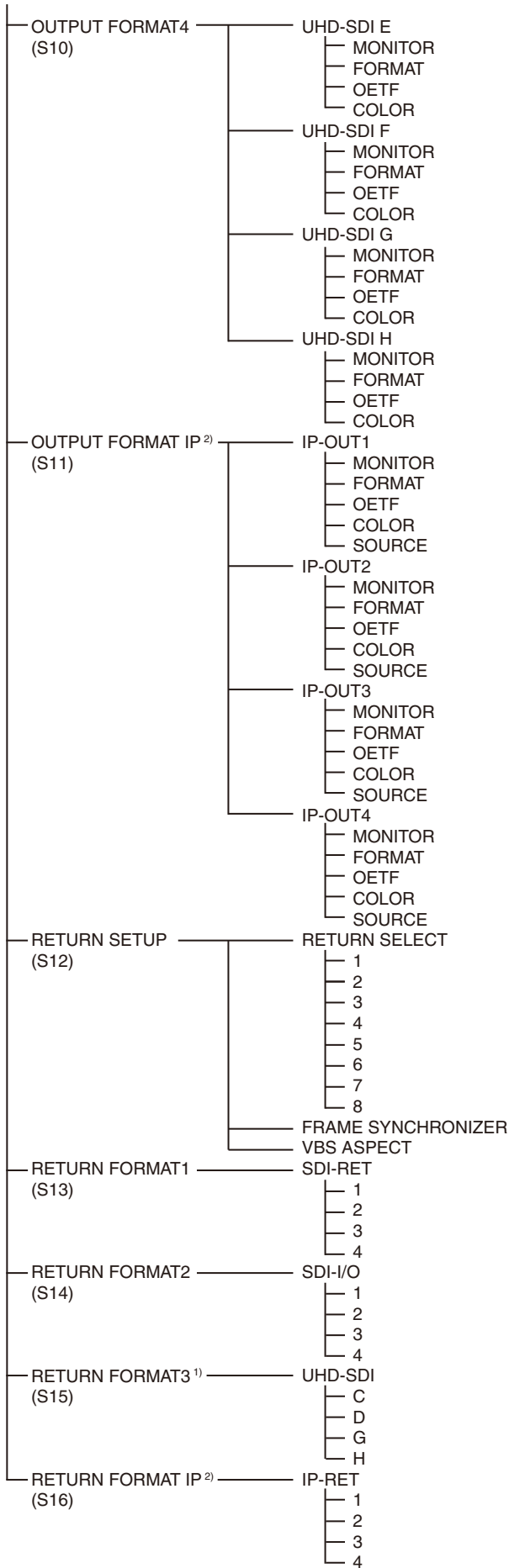

## VIDEO/MONITOR Menu

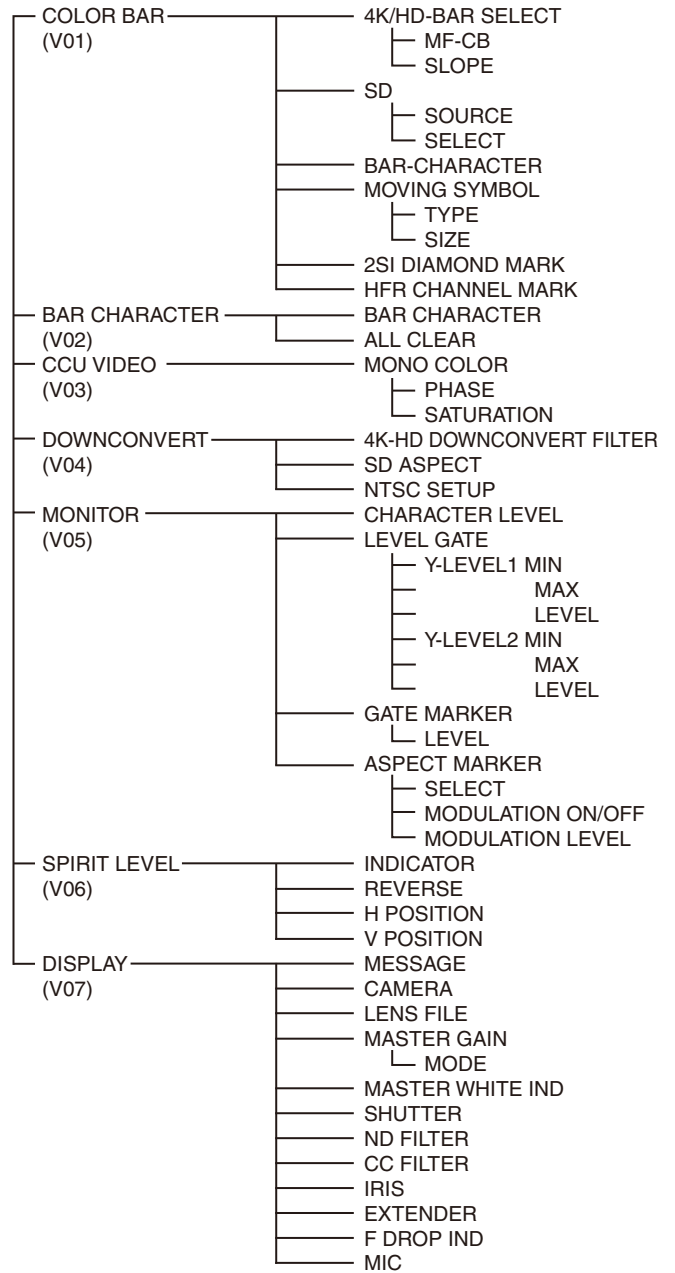

## AUDIO/INTERCOM Menu

Menu items marked "1)" are displayed only when HKCU-SFP50 is installed.

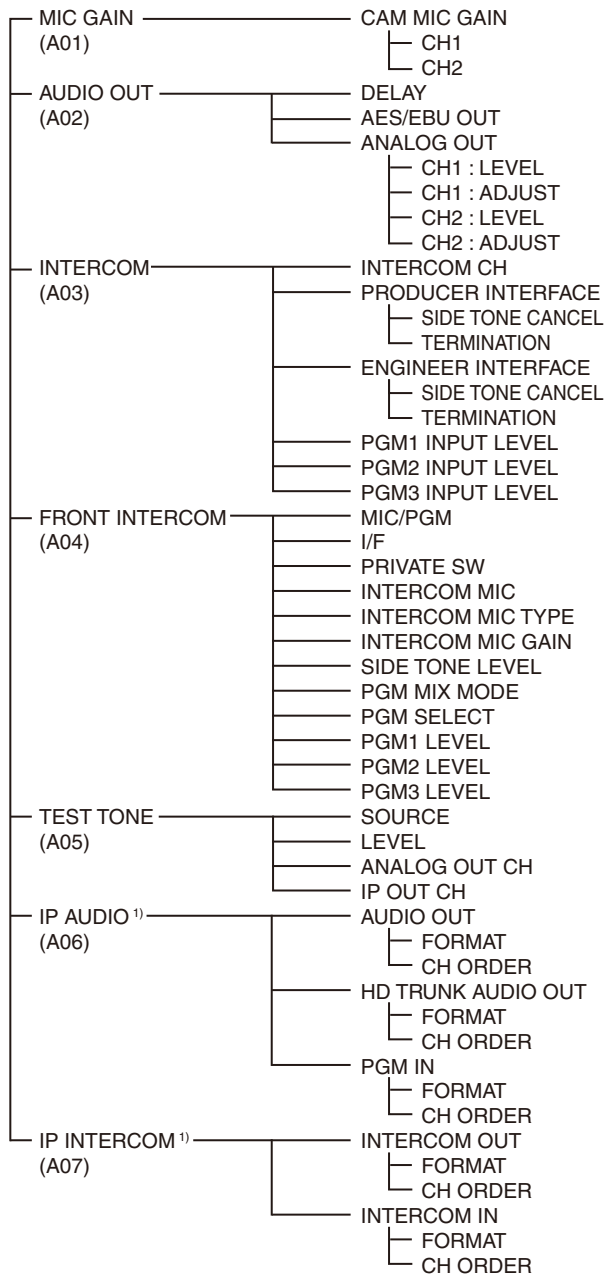

## MAINTENANCE Menu

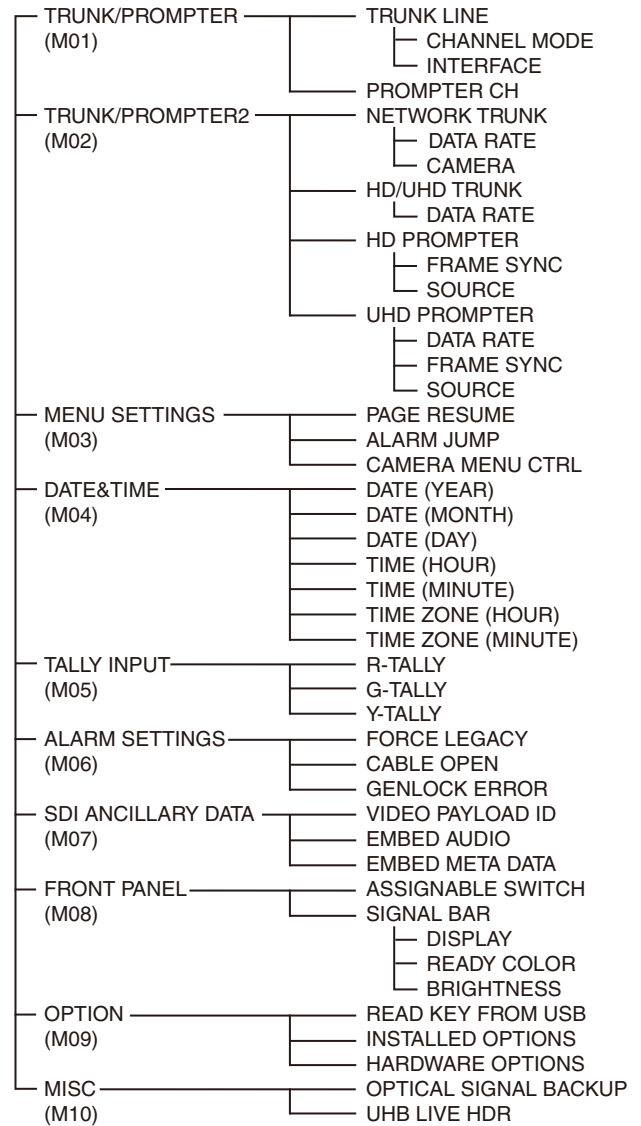

## FILE Menu

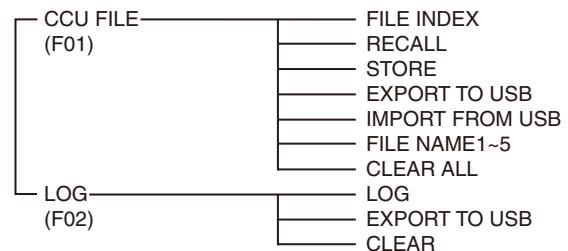

# NETWORK Menu

Menu items marked "1)" are displayed only when HKCU-SFP50 is installed.

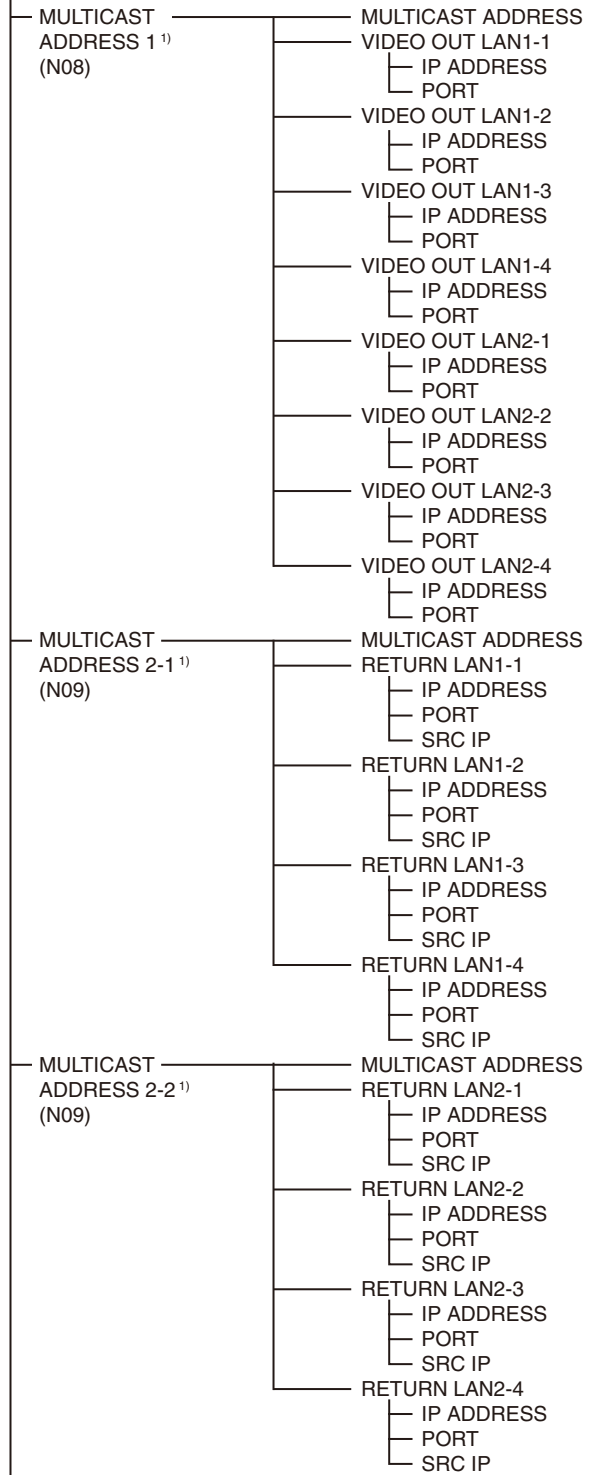
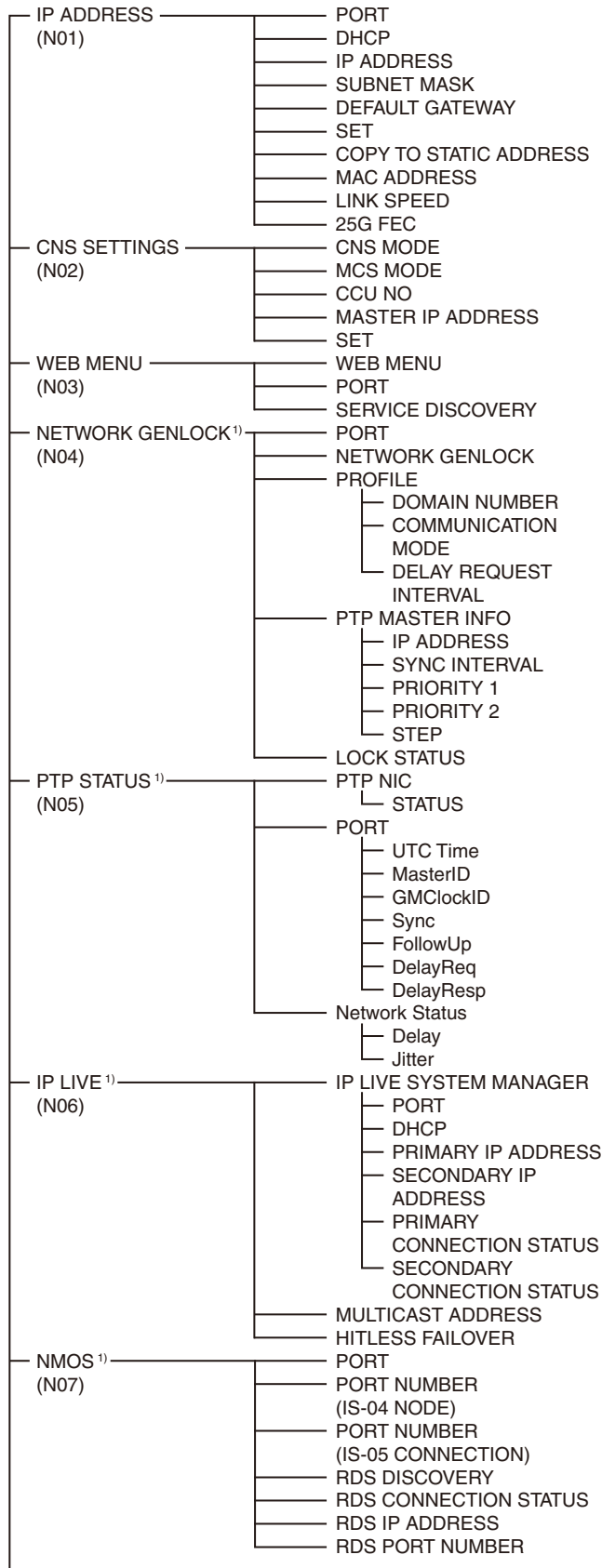

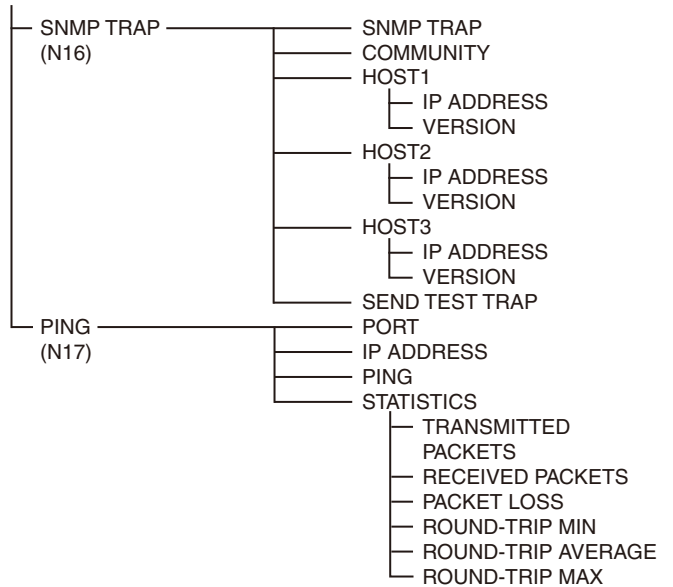
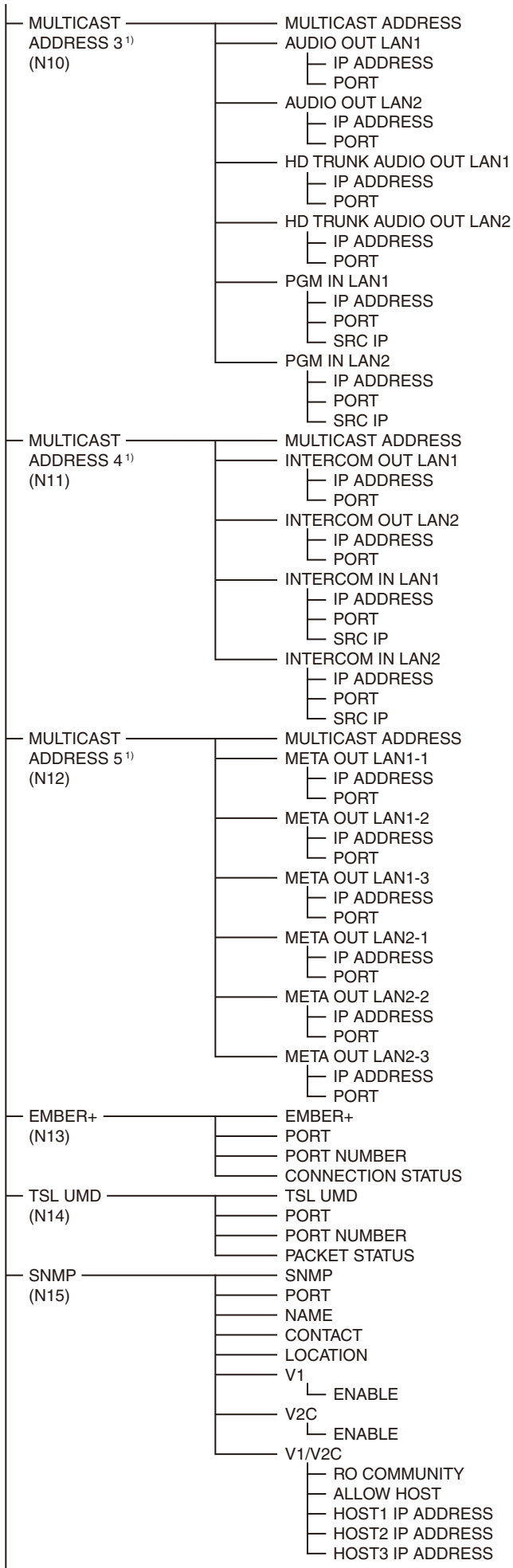

## DIAGNOSIS Menu

Menu items marked "1)" are displayed only on the HDCU5500/3500.

Menu items marked "2)" are displayed only on the HDCU5000.

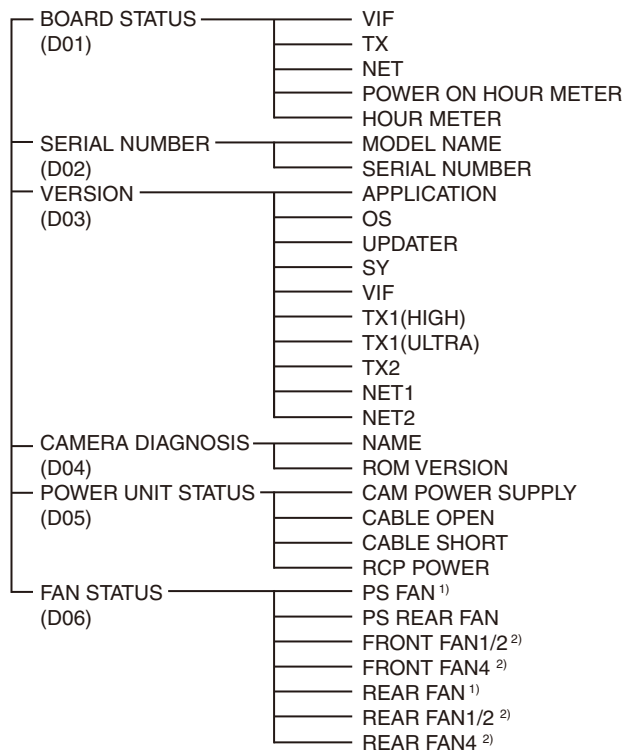

# Menu List

## Legend

The following conventions are used in the menu list table.

**Settings column values (e.g. ON, OFF, 0):** Default settings are underlined

**Execute using ENTER:** When using the setup menu directly, press the CONTROL knob or move the CANCEL/ENTER lever to the ENTER position to execute. When using the web menu, click the ENTER button in the OSD menu to execute.

## SYSTEM CONFIG Menu

SYSTEM CONFIG			
Page name Page No.	Item	Set value	Description
<CAMERA I/F> S01	CABLE TYPE	<u>FIBER CAMERA CABLE</u> , COAX, COAX(HDCE), SINGLE-MODE FIBER	Specifies the cable type used for connecting the camera.  <b>SINGLE-MODE FIBER:</b> Selectable only when the HKCU-SM50 is installed.
	FIBER TRANSMIT RATE	<u>HIGH</u> , ULTRA, ---	Sets the transfer rate when an optical fiber cable is connected.  <b>HIGH:</b> When the HDC3500 (without HKC-FB50 installed), HDC3100, or HDC2000 series is connected <b>ULTRA:</b> When the HDC5000/5500 or HDC3500 (with HKC-FB50 installed) is connected <b>---</b> : When CABLE TYPE is set to COAX or COAX(HDCE)
	OPTICAL SIGNAL	ON, <u>OFF</u>	Turns the optical signal output from the CCU to the camera ON/OFF.  (Displayed only when connected using optical fiber composite cable.)
	BARS	<u>OFF</u> , ON	Turns color bars ON/OFF.
	TEST	<u>OFF</u> , TEST1, TEST2	Turns TEST SAW ON/OFF.
	START UP VIDEO SIGNAL	<u>BARS</u> , GRAY	Selects the signal to output until the unit connects with the camera after power-on.
	<VIDEO I/O> S02	SDI-I/O 1	
I/O		IN, <u>OUT</u>	Selects input or output.
SIGNAL		When OUT is selected in I/O: <u>SDI-OUT</u> When IN is selected in I/O: SDI-RET	Sets the signal function.
SDI-I/O 2			Sets SDI I/O 2.
I/O		IN, <u>OUT</u>	Selects input or output.
SIGNAL		When OUT is selected in I/O: <u>SDI-OUT</u> When IN is selected in I/O: SDI-RET	Sets the signal function.
SDI-I/O 3			Sets SDI I/O 3.
I/O		IN, <u>OUT</u>	Selects input or output.
SIGNAL		When OUT is selected in I/O: SDI-OUT, <u>HD TRUNK</u> When IN is selected in I/O: SDI-RET	Sets the signal function.

**SYSTEM CONFIG**

Page name Page No.	Item	Set value	Description
<VIDEO I/O> S02	SDI-I/O 4		Sets SDI I/O 4.
	I/O	<b>IN</b> , <b>OUT</b>	Selects input or output.
	SIGNAL	When OUT is selected in I/O: SDI-OUT When IN is selected in I/O: SDI-RET, <b>HD PROMPTER</b>	Sets the signal function.
UHD-SDI B	I/O	<b>OUT</b>	Output (fixed)
	SIGNAL	<b>SDI-OUT</b> , UHD TRUNK	Sets the signal function.
	<b>Note</b>		
			UHD TRUNK is available on the HDCU5000/5500 only.
UHD-SDI C	I/O	<b>IN</b> , <b>OUT</b>	Selects input or output.
	SIGNAL	When OUT is selected in I/O: <b>SDI-OUT</b> When IN is selected in I/O: SDI-RET	Sets the signal function.
	UHD-SDI D	I/O	<b>IN</b> , <b>OUT</b>
SIGNAL		When OUT is selected in I/O: <b>SDI-OUT</b> When IN is selected in I/O: SDI-RET, UHD PROMPTER	Sets the signal function.
<b>Note</b>			
			UHD PROMPTER is available on the HDCU5000/5500 only.
UHD-SDI G	I/O	<b>IN</b> , <b>OUT</b>	Selects input or output.
	SIGNAL	When OUT is selected in I/O: <b>SDI-OUT</b> When IN is selected in I/O: SDI-RET	Sets the signal function.
	UHD-SDI H	I/O	<b>IN</b> , <b>OUT</b>
SIGNAL		When OUT is selected in I/O: <b>SDI-OUT</b> When IN is selected in I/O: SDI-RET	Sets the signal function.

SYSTEM CONFIG			
Page name Page No.	Item	Set value	Description
<REAR I/F> S03	CHARACTER	<b>CHARACTER</b> , AES/EBU, SYNC	Sets the function to assign to the CHARACTER, AES/EBU, SYNC connector. <b>CHARACTER</b> : Set to VBS output on which character superposition is performed. <b>AES/EBU</b> : Set to AES/EBU output.  <b>Note</b> AES/EBU is available on the HDCU5500/3500 only. <b>SYNC</b> : Set to SD composite sync or HD tri-level reference sync signal output from the internal sync signal generator.
	PROMPTER2/ VBS-RET	<b>ENABLE</b>	Sets the function to assign to the PROMPTER2/ VBS-RET connector.  <b>Note</b> Set to ENABLE (fixed). <b>ENABLE</b> : Set to both signal input for the second tele-prompter and VBS return signal input.
	MIC/WF REMOTE	<b>MIC REMOTE</b> , WF REMOTE	Switches the function of pins 36 to 43 when a D-Sub 50-pin board is mounted as the INTERCOM/TALLY/ IO PORT connector.
	REAR PREVIEW	<b>MOMENTARY</b> , TOGGLE	Sets the operation mode of the REAR PREVIEW connector output.
<GENLOCK> S04	REFERENCE	NOT DETECTED, EXT IN, 1080/59.94I, 1080/23.98PsF, 720/59.94P, 1080/50I, 1080/24PsF, 720/50P	Signal input of the REFERENCE IN connector (Display only).
	LOCK STATUS	When HD or SD is selected in GENLOCK MODE: LOCKED, NOT LOCKED	Lock status of the external reference signal (Display only).
	GENLOCK MODE	HD, <b>SD</b> , NETWORK	Sets the lock mode of the external reference signal.  <b>Notes</b> • NETWORK is displayed only when the HKCU-SFP50 ST 2110 Interface Kit is installed. • Set to NETWORK if operating within an SMPTE ST 2110 compliant system. • When set to NETWORK, an external reference input on the REFERENCE IN connector is not required, and network synchronization operates using the LAN 1 and LAN 2 connectors of the HKCU-SFP50. The network synchronization setting is configured on the <NETWORK GENLOCK> page of the NETWORK menu.
	10F BB	<b>OFF</b> , ON	Sets whether to use the 10-field ID added to the external reference signal  This can be selected when GENLOCK MODE is SD and <MULTI FORMAT> page → SYSTEM is 1.001(525).
	H-PHASE STEP	When HD is selected in GENLOCK MODE: -3.01 to 3.45 µsec <b>0.00</b> When SD is selected in GENLOCK MODE: -8.29 to 9.48 µsec <b>0.00</b>	Adjusts the horizontal lock phase in relation to the reference signal (steps)
H-PHASE COARSE	-99 to 99, <b>0</b>	Adjusts the horizontal lock phase in relation to the reference signal (fine adjustment)	
V-PHASE	<b>0</b> to 7	Adjusts the vertical lock phase in relation to the reference signal (line)	
SYNC OUT SELECT	<b>SD SYNC</b> , HD SYNC	Sets the output signal of the REFERENCE OUT connector.	



SYSTEM CONFIG			
Page name Page No.	Item	Set value	Description
<MULTI FORMAT> S05	SYSTEM	<b>1.001(525)</b> , 1.000(625)	Selects the operating frequency of the system.
	CAMERA FORMAT	<p>When FIBER TRANSMIT RATE is set to ULTRA and 1.001(525) is selected in SYSTEM: 3840x2160/59.94P(2x), 3840x2160/59.94P, 3840x2160/29.97P, 3840x2160/23.98P, <b>1080/59.94P</b>, 1080/29.97PsF, 1080/23.98PsF, 1080/59.94I (RGB444), 1080/29.97PsF (RGB444), 1080/23.98PsF (RGB444), 1080/59.94P(2x), 1080/59.94P(3x), 1080/59.94P(4x), 1080/59.94P(6x), 1080/59.94P(8x)</p> <p>When FIBER TRANSMIT RATE is set to ULTRA and 1.000(625) is selected in SYSTEM: 3840x2160/50P(2x), 3840x2160/50P, 3840x2160/25P, 3840x2160/24P, <b>1080/50P</b>, 1080/25PsF, 1080/24PsF, 1080/50I (RGB444), 1080/25PsF (RGB444), 1080/24PsF (RGB444), 1080/50P(2x), 1080/50P(3x), 1080/50P(4x), 1080/50P(6x), 1080/50P(8x)</p> <p>When FIBER TRANSMIT RATE is set to HIGH and 1.001(525) is selected in SYSTEM: UHD/59.94P (4K/HDR), 1080/59.94P (4K/HDR), 1080/59.94P, <b>1080/59.94I</b>, 1080/29.97PsF, 1080/23.98PsF, 720/59.94P, 1080/59.94I (RGB444), 1080/29.97PsF (RGB444), 1080/23.98PsF (RGB444), 1080/59.94I(2x), 720/59.94P(2x)</p> <p>When FIBER TRANSMIT RATE is set to HIGH and 1.000(625) is selected in SYSTEM: UHD/50P (4K/HDR), 1080/50P (4K/HDR), 1080/50P, <b>1080/50I</b>, 1080/25PsF, 1080/24PsF, 720/50P, 1080/50I (RGB444), 1080/25PsF (RGB444), 1080/24PsF (RGB444), 1080/50I(2x), 720/50P(2x)</p>	<p>Selects the system format.</p> <p><b>Note</b> The formats available for selection vary depending on the active format of the connected camera.</p>
	BIT DEPTH	10BIT, 12BIT	<p>Sets the RGB4:4:4 output bit length, and changes the CCU output format.</p> <p>This can be selected only when CAMERA FORMAT is set to 1080/59.94I (RGB444), 1080/29.97PsF (RGB444), 1080/23.98PsF (RGB444), 1080/50I (RGB444), 1080/25PsF (RGB444), or 1080/24PsF (RGB444).</p>

SYSTEM CONFIG																					
Page name Page No.	Item	Set value	Description																		
<MULTI FORMAT> S05	CCU VIDEO CONVERT	<b>DISABLE</b> , ENABLE	Sets the video converter function. Set to ENABLE when CAMERA FORMAT is set to the following.																		
			<table border="1"> <thead> <tr> <th>CAMERA FORMAT</th> <th>Conversion output</th> </tr> </thead> <tbody> <tr> <td>3840x2160/59.94P(2x)</td> <td>720/59.94P</td> </tr> <tr> <td>3840x2160/59.94P UHD/59.94P(4K/HDR)</td> <td></td> </tr> <tr> <td>1080/59.94P(4K/HDR)</td> <td></td> </tr> <tr> <td>1080/59.94P 1080/59.94P(2x), (3x), (4x), (6x), (8x)</td> <td></td> </tr> <tr> <td>3840x2160/50P(2x)</td> <td>720/50P</td> </tr> <tr> <td>3840x2160/50P UHD/50P(4K/HDR)</td> <td></td> </tr> <tr> <td>1080/50P(4K/HDR)</td> <td></td> </tr> <tr> <td>1080/50P 1080/50P(2x), (3x), (4x), (6x), (8x)</td> <td></td> </tr> </tbody> </table>	CAMERA FORMAT	Conversion output	3840x2160/59.94P(2x)	720/59.94P	3840x2160/59.94P UHD/59.94P(4K/HDR)		1080/59.94P(4K/HDR)		1080/59.94P 1080/59.94P(2x), (3x), (4x), (6x), (8x)		3840x2160/50P(2x)	720/50P	3840x2160/50P UHD/50P(4K/HDR)		1080/50P(4K/HDR)		1080/50P 1080/50P(2x), (3x), (4x), (6x), (8x)	
			CAMERA FORMAT	Conversion output																	
3840x2160/59.94P(2x)	720/59.94P																				
3840x2160/59.94P UHD/59.94P(4K/HDR)																					
1080/59.94P(4K/HDR)																					
1080/59.94P 1080/59.94P(2x), (3x), (4x), (6x), (8x)																					
3840x2160/50P(2x)	720/50P																				
3840x2160/50P UHD/50P(4K/HDR)																					
1080/50P(4K/HDR)																					
1080/50P 1080/50P(2x), (3x), (4x), (6x), (8x)																					
When ENABLE is selected, set FRAME SYNCHRONIZER to ON. <b>Tip:</b> When CCU VIDEO CONVERT is set to ENABLE, the video convert function within the CCU introduces a delay, which is compensated for by advancing the camera signal.																					
FRAME CONVERT DELAY	0.8, 1.2, <b>1.6</b> [F@23.98PsF]	Sets the video delay time for 2-3 Pulldown. This is enabled only when SYSTEM is 1.001(525).																			
HD-SD DELAY	LINE, <b>FRAME</b> 90H, 120H, <b>1E</b> , 2F	Sets the delay for SD signals down-converted from HD signals. The delay duration display will be as follows when CAMERA FORMAT is set to a 1080 format. <b>When LINE is selected:</b> 90H <b>When FRAME is selected:</b> 1F The delay duration display will be as follows when CAMERA FORMAT is set to a 720 format. <b>When LINE is selected:</b> 120H <b>When FRAME is selected:</b> 2F																			

**SYSTEM CONFIG**

Page name Page No.	Item	Set value	Description
<HDR> S06	HDR MODE	<b>OFF</b> , LIVE HDR	<b>OFF</b> : Normal shooting operation. <b>LIVE HDR</b> : Used for LIVE HDR shooting.
	<div style="text-align: right;"><b>Note</b></div> <p>When LIVE HDR is selected, camera paint functions can be used for both HDR output and SDR output. However, some paint functions are not supported for HDR output.</p>		
	SDR GAIN	-15 to 0.0, <b>0</b> dB	Enabled in LIVE HDR mode only. Gain setting applied to SDR output
	HDR CONTRAST	<b>100</b> to 560%	Enabled in LIVE HDR mode only. HDR output contrast maintained by setting SDR GAIN (Display only)
	HDR BLACK OFFSET	-99 to 99, <b>0</b>	Enabled in LIVE HDR mode only. HDR output black offset
	HDR OETF	<b>S-Log3</b> , HLG	Sets the video output OETF.
	HDR LOOK	Natural, Mild, <b>Live</b>	Sets the video output LOOK.
	HDR COLOR SPACE	<b>BT709</b> , BT2020	Selects the color space of the video output. <b>BT709</b> : Sets the color output format to BT709. <b>BT2020</b> : Sets the color output format to BT2020.
	4K COLOR SPACE	<b>BT709</b> , BT2020	Selects the color space of 4K video output. Same settings as HDR COLOR SPACE when HDR MODE is set to LIVE HDR. <b>BT709</b> : Sets the color output format to BT709. <b>BT2020</b> : Sets the color output format to BT2020.

**SYSTEM CONFIG**

Page name Page No.	Item	Set value	Description	
<OUTPUT FORMAT1> S07	SDI-OUT1		Sets the output for the SDI OUT 1 connector.	
	MONITOR	C	Sets whether to add characters to the output signal. <b>C:</b> Characters are not added.	
	<b>Note</b>			
	This is fixed to C.			
	FORMAT	<i>FIBER TRANSMIT RATE is HIGH and SYSTEM is 1.001(525): see page 54</i> <i>FIBER TRANSMIT RATE is HIGH and SYSTEM is 1.000(625): see page 56</i> <i>FIBER TRANSMIT RATE is ULTRA and SYSTEM is 1.001(525): see page 58</i> <i>FIBER TRANSMIT RATE is ULTRA and SYSTEM is 1.000(625): see page 62</i>		Sets the output signal format of the SDI OUT 1 connector.
	OETF	<b>SDR</b> , HDR OETF		Sets the gamma curve of the video output.
	COLOR	BT709, BT2020		Selects the color space of SDI-OUT1 video output. <b>BT709:</b> Sets the color output format to BT709. <b>BT2020:</b> Sets the color output format to BT2020.
	SDI-OUT2		Sets the output for the SDI OUT 2 connector.	
	MONITOR	C	Sets whether to add characters to the output signal. <b>C:</b> Characters are not added.	
	<b>Note</b>			
This is fixed to C.				
	FORMAT	<i>FIBER TRANSMIT RATE is HIGH and SYSTEM is 1.001(525): see page 54</i> <i>FIBER TRANSMIT RATE is HIGH and SYSTEM is 1.000(625): see page 56</i> <i>FIBER TRANSMIT RATE is ULTRA and SYSTEM is 1.001(525): see page 58</i> <i>FIBER TRANSMIT RATE is ULTRA and SYSTEM is 1.000(625): see page 62</i>	Sets the output signal format of the SDI OUT 2 connector.	
	OETF	<b>SDR</b> , HDR OETF	Sets the gamma curve of the video output.	
	COLOR	BT709, BT2020	Selects the color space of SDI-OUT2 video output. <b>BT709:</b> Sets the color output format to BT709. <b>BT2020:</b> Sets the color output format to BT2020.	

**SYSTEM CONFIG**

Page name Page No.	Item	Set value	Description	
<OUTPUT FORMAT1> S07	SDI-OUT3		Sets the output for the SDI OUT 3 connector.	
	MONITOR	C, <b>M</b>	Sets whether to add characters to the output signal. <b>C</b> : Characters are not added. <b>M</b> : Characters are added.	
	FORMAT	<i>FIBER TRANSMIT RATE is HIGH and SYSTEM is 1.001(525): see page 54</i> <i>FIBER TRANSMIT RATE is HIGH and SYSTEM is 1.000(625): see page 56</i> <i>FIBER TRANSMIT RATE is ULTRA and SYSTEM is 1.001(525): see page 58</i> <i>FIBER TRANSMIT RATE is ULTRA and SYSTEM is 1.000(625): see page 62</i>	Sets the output signal format of the SDI OUT 3 connector.	
	OETF	<b>SDR</b> , HDR OETF	Sets the gamma curve of the video output.	
	COLOR	BT709, BT2020	Selects the color space of SDI-OUT3 video output. <b>BT709</b> : Sets the color output format to BT709. <b>BT2020</b> : Sets the color output format to BT2020.	
	SDI-OUT4		Sets the output for the SDI OUT 4 connector.	
	MONITOR	C, <b>M</b>	Sets whether to add characters to the output signal. <b>C</b> : Characters are not added. <b>M</b> : Characters are added.	
				<p><b>Note</b></p> <p>When this is set to C (characters are not added), the CCU MENU will not be displayed. To display it, hold the DISP/MENU lever in the MENU position for 3 seconds.</p>
	FORMAT	<i>FIBER TRANSMIT RATE is HIGH and SYSTEM is 1.001(525): see page 54</i> <i>FIBER TRANSMIT RATE is HIGH and SYSTEM is 1.000(625): see page 56</i> <i>FIBER TRANSMIT RATE is ULTRA and SYSTEM is 1.001(525): see page 58</i> <i>FIBER TRANSMIT RATE is ULTRA and SYSTEM is 1.000(625): see page 62</i>	Sets the output signal format of the SDI OUT 4 connector.	
	OETF	<b>SDR</b> , HDR OETF	Sets the gamma curve of the video output.	
COLOR	BT709, BT2020	Selects the color space of SDI-OUT4 video output. <b>BT709</b> : Sets the color output format to BT709. <b>BT2020</b> : Sets the color output format to BT2020.		

**SYSTEM CONFIG**

Page name Page No.	Item	Set value	Description	
<OUTPUT FORMAT2> S08	SDI-I/O1		Sets the output for the SDI I/O 1 connector.	
	MONITOR	C	Sets whether to add characters to the output signal. <b>C:</b> Characters are not added.	
	<b>Note</b>			
	This is fixed to C.			
	FORMAT	<i>FIBER TRANSMIT RATE is HIGH and SYSTEM is 1.001(525): see page 54</i> <i>FIBER TRANSMIT RATE is HIGH and SYSTEM is 1.000(625): see page 56</i> <i>FIBER TRANSMIT RATE is ULTRA and SYSTEM is 1.001(525): see page 58</i> <i>FIBER TRANSMIT RATE is ULTRA and SYSTEM is 1.000(625): see page 62</i>		Sets the output signal format of the SDI I/O 1 connector.
	OETF	<b>SDR</b> , HDR OETF		Sets the gamma curve of the video output.
	COLOR	BT709, BT2020		Selects the color space of SDI-I/O1 video output. <b>BT709:</b> Sets the color output format to BT709. <b>BT2020:</b> Sets the color output format to BT2020.
	SDI-I/O2		Sets the output for the SDI I/O 2 connector.	
	MONITOR	C	Sets whether to add characters to the output signal. <b>C:</b> Characters are not added.	
	<b>Note</b>			
This is fixed to C.				
FORMAT	<i>FIBER TRANSMIT RATE is HIGH and SYSTEM is 1.001(525): see page 54</i> <i>FIBER TRANSMIT RATE is HIGH and SYSTEM is 1.000(625): see page 56</i> <i>FIBER TRANSMIT RATE is ULTRA and SYSTEM is 1.001(525): see page 58</i> <i>FIBER TRANSMIT RATE is ULTRA and SYSTEM is 1.000(625): see page 62</i>		Sets the output signal format of the SDI I/O 2 connector.	
OETF	<b>SDR</b> , HDR OETF		Sets the gamma curve of the video output.	
COLOR	BT709, BT2020		Selects the color space of SDI-I/O2 video output. <b>BT709:</b> Sets the color output format to BT709. <b>BT2020:</b> Sets the color output format to BT2020.	

**SYSTEM CONFIG**

Page name Page No.	Item	Set value	Description	
<OUTPUT FORMAT2> S08	SDI-I/O3		Sets the output for the SDI I/O 3 connector.	
	MONITOR	C	Sets whether to add characters to the output signal. <b>C:</b> Characters are not added.	
	<b>Note</b>			
	This is fixed to C.			
	FORMAT	<i>FIBER TRANSMIT RATE is HIGH and SYSTEM is 1.001(525): see page 54</i> <i>FIBER TRANSMIT RATE is HIGH and SYSTEM is 1.000(625): see page 56</i> <i>FIBER TRANSMIT RATE is ULTRA and SYSTEM is 1.001(525): see page 58</i> <i>FIBER TRANSMIT RATE is ULTRA and SYSTEM is 1.000(625): see page 62</i>		Sets the output signal format of the SDI I/O 3 connector.
	OETF	<b>SDR</b> , HDR OETF		Sets the gamma curve of the video output.
	COLOR	BT709, BT2020		Selects the color space of SDI-I/O3 video output. <b>BT709:</b> Sets the color output format to BT709. <b>BT2020:</b> Sets the color output format to BT2020.
	SDI-I/O4		Sets the output for the SDI I/O 4 connector.	
	MONITOR	C	Sets whether to add characters to the output signal. <b>C:</b> Characters are not added.	
	<b>Note</b>			
This is fixed to C.				
	FORMAT	<i>FIBER TRANSMIT RATE is HIGH and SYSTEM is 1.001(525): see page 54</i> <i>FIBER TRANSMIT RATE is HIGH and SYSTEM is 1.000(625): see page 56</i> <i>FIBER TRANSMIT RATE is ULTRA and SYSTEM is 1.001(525): see page 58</i> <i>FIBER TRANSMIT RATE is ULTRA and SYSTEM is 1.000(625): see page 62</i>	Sets the output signal format of the SDI I/O 4 connector.	
	OETF	<b>SDR</b> , HDR OETF	Sets the gamma curve of the video output.	
	COLOR	BT709, BT2020	Selects the color space of SDI-I/O4 video output. <b>BT709:</b> Sets the color output format to BT709. <b>BT2020:</b> Sets the color output format to BT2020.	

**SYSTEM CONFIG**

Page name Page No.	Item	Set value	Description	
<OUTPUT FORMAT3> S09	UHD-SDI A		Sets the output of the UHD SDI A connector.	
	MONITOR	C	Sets whether to add characters to the output signal. <b>C:</b> Characters are not added.	
	<b>Note</b>			
	This is fixed to C.			
	FORMAT	<i>FIBER TRANSMIT RATE is HIGH and SYSTEM is 1.001(525): see page 54</i> <i>FIBER TRANSMIT RATE is HIGH and SYSTEM is 1.000(625): see page 56</i> <i>FIBER TRANSMIT RATE is ULTRA and SYSTEM is 1.001(525): see page 58</i> <i>FIBER TRANSMIT RATE is ULTRA and SYSTEM is 1.000(625): see page 62</i>		Sets the output signal format of the UHD SDI A connector.
	OETF	SDR, 4K OETF		Sets the gamma curve of the video output.
	COLOR	BT709, BT2020		Selects the color space of UHD-SDI A video output. <b>BT709:</b> Sets the color output format to BT709. <b>BT2020:</b> Sets the color output format to BT2020.
	UHD-SDI B		Sets the output of the UHD SDI B connector.	
	MONITOR	C	Sets whether to add characters to the output signal. <b>C:</b> Characters are not added.	
	<b>Note</b>			
This is fixed to C.				
FORMAT	<i>FIBER TRANSMIT RATE is HIGH and SYSTEM is 1.001(525): see page 54</i> <i>FIBER TRANSMIT RATE is HIGH and SYSTEM is 1.000(625): see page 56</i> <i>FIBER TRANSMIT RATE is ULTRA and SYSTEM is 1.001(525): see page 58</i> <i>FIBER TRANSMIT RATE is ULTRA and SYSTEM is 1.000(625): see page 62</i>		Sets the output signal format of the UHD SDI B connector.	
OETF	SDR, 4K OETF		Sets the gamma curve of the video output.	
COLOR	BT709, BT2020		Selects the color space of UHD-SDI B video output. <b>BT709:</b> Sets the color output format to BT709. <b>BT2020:</b> Sets the color output format to BT2020.	



**SYSTEM CONFIG**

Page name Page No.	Item	Set value	Description	
<OUTPUT FORMAT3> S09	UHD-SDI C		Sets the output of the UHD SDI C connector.	
	MONITOR	C	Sets whether to add characters to the output signal. <b>C:</b> Characters are not added.	
	<b>Note</b>			
	This is fixed to C.			
	FORMAT	<i>FIBER TRANSMIT RATE is HIGH and SYSTEM is 1.001(525): see page 54</i> <i>FIBER TRANSMIT RATE is HIGH and SYSTEM is 1.000(625): see page 56</i> <i>FIBER TRANSMIT RATE is ULTRA and SYSTEM is 1.001(525): see page 58</i> <i>FIBER TRANSMIT RATE is ULTRA and SYSTEM is 1.000(625): see page 62</i>		Sets the output signal format of the UHD SDI C connector.
	OETF	SDR, 4K OETF		Sets the gamma curve of the video output.
	COLOR	BT709, BT2020		Selects the color space of UHD-SDI C video output. <b>BT709:</b> Sets the color output format to BT709. <b>BT2020:</b> Sets the color output format to BT2020.
	UHD-SDI D		Sets the output of the UHD SDI D connector.	
	MONITOR	C	Sets whether to add characters to the output signal. <b>C:</b> Characters are not added.	
	<b>Note</b>			
This is fixed to C.				
FORMAT	<i>FIBER TRANSMIT RATE is HIGH and SYSTEM is 1.001(525): see page 54</i> <i>FIBER TRANSMIT RATE is HIGH and SYSTEM is 1.000(625): see page 56</i> <i>FIBER TRANSMIT RATE is ULTRA and SYSTEM is 1.001(525): see page 58</i> <i>FIBER TRANSMIT RATE is ULTRA and SYSTEM is 1.000(625): see page 62</i>		Sets the output signal format of the UHD SDI D connector.	
OETF	SDR, 4K OETF		Sets the gamma curve of the video output.	
COLOR	BT709, BT2020		Selects the color space of UHD-SDI D video output. <b>BT709:</b> Sets the color output format to BT709. <b>BT2020:</b> Sets the color output format to BT2020.	

**SYSTEM CONFIG**

Page name Page No.	Item	Set value	Description
<OUTPUT FORMAT4> S10 Displayed only when HKCU-SDI50 is installed.	UHD-SDI E		Sets the output of the UHD SDI E connector.
	MONITOR	C	Sets whether to add characters to the output signal. <b>C:</b> Characters are not added.
	<b>Note</b>		
	This is fixed to C.		
	FORMAT	<i>FIBER TRANSMIT RATE is HIGH and SYSTEM is 1.001(525): see page 54</i> <i>FIBER TRANSMIT RATE is HIGH and SYSTEM is 1.000(625): see page 56</i> <i>FIBER TRANSMIT RATE is ULTRA and SYSTEM is 1.001(525): see page 58</i> <i>FIBER TRANSMIT RATE is ULTRA and SYSTEM is 1.000(625): see page 62</i>	Sets the output signal format of the UHD SDI E connector.
	OETF	SDR, 4K OETF	Sets the gamma curve of the video output.
	COLOR	BT709, BT2020	Selects the color space of UHD-SDI E video output. <b>BT709:</b> Sets the color output format to BT709. <b>BT2020:</b> Sets the color output format to BT2020.
	UHD-SDI F		Sets the output of the UHD SDI F connector.
	MONITOR	C	Sets whether to add characters to the output signal. <b>C:</b> Characters are not added.
	<b>Note</b>		
This is fixed to C.			
FORMAT	<i>FIBER TRANSMIT RATE is HIGH and SYSTEM is 1.001(525): see page 54</i> <i>FIBER TRANSMIT RATE is HIGH and SYSTEM is 1.000(625): see page 56</i> <i>FIBER TRANSMIT RATE is ULTRA and SYSTEM is 1.001(525): see page 58</i> <i>FIBER TRANSMIT RATE is ULTRA and SYSTEM is 1.000(625): see page 62</i>	Sets the output signal format of the UHD SDI F connector.	
OETF	SDR, 4K OETF	Sets the gamma curve of the video output.	
COLOR	BT709, BT2020	Selects the color space of UHD-SDI F video output. <b>BT709:</b> Sets the color output format to BT709. <b>BT2020:</b> Sets the color output format to BT2020.	

SYSTEM CONFIG			
Page name Page No.	Item	Set value	Description
<OUTPUT FORMAT4> S10 Displayed only when HKCU-SDI50 is installed.	UHD-SDI G		Sets the output of the UHD SDI G connector.
	MONITOR	C	Sets whether to add characters to the output signal. <b>C:</b> Characters are not added.
	<b>Note</b>		
	This is fixed to C.		
	FORMAT	<i>FIBER TRANSMIT RATE is HIGH and SYSTEM is 1.001(525): see page 54</i> <i>FIBER TRANSMIT RATE is HIGH and SYSTEM is 1.000(625): see page 56</i> <i>FIBER TRANSMIT RATE is ULTRA and SYSTEM is 1.001(525): see page 58</i> <i>FIBER TRANSMIT RATE is ULTRA and SYSTEM is 1.000(625): see page 62</i>	Sets the output signal format of the UHD SDI G connector.
	OETF	SDR, 4K OETF	Sets the gamma curve of the video output.
	COLOR	BT709, BT2020	Selects the color space of UHD-SDI G video output. <b>BT709:</b> Sets the color output format to BT709. <b>BT2020:</b> Sets the color output format to BT2020.
	UHD-SDI H		Sets the output of the UHD SDI H connector.
	MONITOR	C	Sets whether to add characters to the output signal. <b>C:</b> Characters are not added.
	<b>Note</b>		
This is fixed to C.			
FORMAT	<i>FIBER TRANSMIT RATE is HIGH and SYSTEM is 1.001(525): see page 54</i> <i>FIBER TRANSMIT RATE is HIGH and SYSTEM is 1.000(625): see page 56</i> <i>FIBER TRANSMIT RATE is ULTRA and SYSTEM is 1.001(525): see page 58</i> <i>FIBER TRANSMIT RATE is ULTRA and SYSTEM is 1.000(625): see page 62</i>	Sets the output signal format of the UHD SDI H connector.	
OETF	SDR, 4K OETF	Sets the gamma curve of the video output.	
COLOR	BT709, BT2020	Selects the color space of UHD-SDI H video output. <b>BT709:</b> Sets the color output format to BT709. <b>BT2020:</b> Sets the color output format to BT2020.	

**SYSTEM CONFIG**

Page name Page No.	Item	Set value	Description	
<OUTPUT FORMAT IP> S11 Displayed only when HKCU-SFP50 is installed.	IP-OUT1		Sets the output for the LAN 1 and LAN 2 connectors.	
	MONITOR	C	Sets whether to add characters to the output signal. <b>C:</b> Characters are not added.	
	<b>Note</b>			
	This is fixed to C.			
	FORMAT	<i>FIBER TRANSMIT RATE is HIGH and SYSTEM is 1.001(525): see page 54</i> <i>FIBER TRANSMIT RATE is HIGH and SYSTEM is 1.000(625): see page 56</i> <i>FIBER TRANSMIT RATE is ULTRA and SYSTEM is 1.001(525): see page 58</i> <i>FIBER TRANSMIT RATE is ULTRA and SYSTEM is 1.000(625): see page 62</i>		Sets the output signal format of the LAN 1 and LAN 2 connectors.
	OETF	<b>SDR</b> , HDR OETF		Sets the gamma curve of the video output.
	COLOR	BT709, BT2020		Selects the color space of IP-OUT1 video output. <b>BT709:</b> Sets the color output format to BT709. <b>BT2020:</b> Sets the color output format to BT2020.
	SOURCE	CAMERA		Selects the signal source to output.
	IP-OUT2			Sets the output for the LAN 1 and LAN 2 connectors.
	MONITOR	<b>C</b> , M		Sets whether to add characters to the output signal. <b>C:</b> Characters are not added. <b>M:</b> Characters are added.
FORMAT	<i>FIBER TRANSMIT RATE is HIGH and SYSTEM is 1.001(525): see page 54</i> <i>FIBER TRANSMIT RATE is HIGH and SYSTEM is 1.000(625): see page 56</i> <i>FIBER TRANSMIT RATE is ULTRA and SYSTEM is 1.001(525): see page 58</i> <i>FIBER TRANSMIT RATE is ULTRA and SYSTEM is 1.000(625): see page 62</i>		Sets the output signal format of the LAN 1 and LAN 2 connectors.	
OETF	<b>SDR</b> , HDR OETF		Sets the gamma curve of the video output.	
COLOR	BT709, BT2020		Selects the color space of IP-OUT2 video output. <b>BT709:</b> Sets the color output format to BT709. <b>BT2020:</b> Sets the color output format to BT2020.	
SOURCE	CAMERA		Selects the signal source to output.	

SYSTEM CONFIG				
Page name Page No.	Item	Set value	Description	
<OUTPUT FORMAT IP> S11 Displayed only when HKCU-SFP50 is installed.	IP-OUT3		Sets the output for the LAN 1 and LAN 2 connectors.	
	MONITOR	C, <b>M</b>	Sets whether to add characters to the output signal. <b>C</b> : Characters are not added. <b>M</b> : Characters are added.	
	<b>Notes</b>			
	<ul style="list-style-type: none"> <li>Fixed to M when SOURCE is set to CAMERA.</li> <li>Fixed to C when SOURCE is set to HD TRUNK.</li> </ul>			
	FORMAT	<i>FIBER TRANSMIT RATE is HIGH and SYSTEM is 1.001(525): see page 54</i> <i>FIBER TRANSMIT RATE is HIGH and SYSTEM is 1.000(625): see page 56</i> <i>FIBER TRANSMIT RATE is ULTRA and SYSTEM is 1.001(525): see page 58</i> <i>FIBER TRANSMIT RATE is ULTRA and SYSTEM is 1.000(625): see page 62</i>		Sets the output signal format of the LAN 1 and LAN 2 connectors.
	OETF	SDR		Sets the gamma curve of the video output.
	COLOR	<b>BT709</b>		Selects the color space of IP-OUT3 video output. <b>BT709</b> : Sets the color output format to BT709.
	SOURCE	<b>CAMERA</b> , HD TRUNK		Selects the signal source to output.
	IP-OUT4			Sets the output for the LAN 1 and LAN 2 connectors.
	<b>Notes</b>			
<ul style="list-style-type: none"> <li>IP-OUT4 is a setting for dedicated 4K output.</li> <li>Output is supported on the HDCU3500 when the HZCU-UHD35 option is enabled.</li> </ul>				
MONITOR	C		Sets whether to add characters to the output signal. <b>C</b> : Characters are not added.	
<b>Note</b>				
This is fixed to C.				
FORMAT	<i>FIBER TRANSMIT RATE is HIGH and SYSTEM is 1.001(525): see page 54</i> <i>FIBER TRANSMIT RATE is HIGH and SYSTEM is 1.000(625): see page 56</i> <i>FIBER TRANSMIT RATE is ULTRA and SYSTEM is 1.001(525): see page 58</i> <i>FIBER TRANSMIT RATE is ULTRA and SYSTEM is 1.000(625): see page 62</i>		Sets the output signal format of the LAN 1 and LAN 2 connectors.	
OETF	<b>SDR</b> , HDR OETF		Sets the gamma curve of the video output.	
COLOR	BT709, BT2020		Selects the color space of IP-OUT4 video output.	
SOURCE	CAMERA		Selects the signal source to output.	

SYSTEM CONFIG			
Page name Page No.	Item	Set value	Description
<RETURN SETUP> S12	RETURN SELECT		Sets the format of the return signal to be input.
	1	<b>SDI-RET1</b> , SDI-RET2, SDI-RET3, SDI-RET4, SDI-I/O1, SDI-I/O2, SDI-I/O3, SDI-I/O4, UHD-SDI C, UHD-SDI D, UHD-SDI G, UHD-SDI H, VBS-RET, IP-RET1, IP-RET2, IP-RET3, IP-RET4	For details on the selectable RETURN FORMAT options for each SYSTEM (system operating frequency) setting and CAMERA FORMAT (system format) setting in <MULTI FORMAT>, see the following. <i>FIBER TRANSMIT RATE is HIGH and SYSTEM is 1.001(525): page 54</i>
	2	SDI-RET1, <b>SDI-RET2</b> , SDI-RET3, SDI-RET4, SDI-I/O1, SDI-I/O2, SDI-I/O3, SDI-I/O4, UHD-SDI C, UHD-SDI D, UHD-SDI G, UHD-SDI H, VBS-RET, IP-RET1, IP-RET2, IP-RET3, IP-RET4	<i>FIBER TRANSMIT RATE is HIGH and SYSTEM is 1.000(625): page 56</i> <i>FIBER TRANSMIT RATE is ULTRA and SYSTEM is 1.001(525): page 58</i>
	3	SDI-RET1, SDI-RET2, <b>SDI-RET3</b> , SDI-RET4, SDI-I/O1, SDI-I/O2, SDI-I/O3, SDI-I/O4, UHD-SDI C, UHD-SDI D, UHD-SDI G, UHD-SDI H, VBS-RET, IP-RET1, IP-RET2, IP-RET3, IP-RET4	<i>FIBER TRANSMIT RATE is ULTRA and SYSTEM is 1.000(625): page 62</i>
	4	SDI-RET1, SDI-RET2, SDI-RET3, <b>SDI-RET4</b> , SDI-I/O1, SDI-I/O2, SDI-I/O3, SDI-I/O4, UHD-SDI C, UHD-SDI D, UHD-SDI G, UHD-SDI H, VBS-RET, IP-RET1, IP-RET2, IP-RET3, IP-RET4	
	5	SDI-RET1, SDI-RET2, SDI-RET3, SDI-RET4, <b>SDI-I/O1</b> , SDI-I/O2, SDI-I/O3, SDI-I/O4, UHD-SDI C, UHD-SDI D, UHD-SDI G, UHD-SDI H, VBS-RET, IP-RET1, IP-RET2, IP-RET3, IP-RET4	
	6	SDI-RET1, SDI-RET2, SDI-RET3, SDI-RET4, SDI-I/O1, <b>SDI-I/O2</b> , SDI-I/O3, SDI-I/O4, UHD-SDI C, UHD-SDI D, UHD-SDI G, UHD-SDI H, VBS-RET, IP-RET1, IP-RET2, IP-RET3, IP-RET4	
	7	SDI-RET1, SDI-RET2, SDI-RET3, SDI-RET4, SDI-I/O1, SDI-I/O2, <b>SDI-I/O3</b> , SDI-I/O4, UHD-SDI C, UHD-SDI D, UHD-SDI G, UHD-SDI H, VBS-RET, IP-RET1, IP-RET2, IP-RET3, IP-RET4	
	8	SDI-RET1, SDI-RET2, SDI-RET3, SDI-RET4, SDI-I/O1, SDI-I/O2, SDI-I/O3, <b>SDI-I/O4</b> , UHD-SDI C, UHD-SDI D, UHD-SDI G, UHD-SDI H, VBS-RET, IP-RET1, IP-RET2, IP-RET3, IP-RET4	
		FRAME SYNCHRONIZER	<b>OFF</b> , ON
	VBS ASPECT	SQUEEZE, LETTER BOX, <b>EDGE CROP</b>	Sets the aspect ratio of the VBS input signal.
<RETURN FORMAT1> S13	SDI-RET		
	1	1080/59.94P/3G, 1080/50P/3G	Sets the format of the return signal to be input to the SDI RET connectors.
	2	<b>1080/59.94I(PsF)</b> , 50I(PsF), 1080/23.98PsF, 24PsF,	
	3	720/59.94P, 50P, 525/59.94I(PsF), 625/50I(PsF)	When an SD signal is set (525 or 625), set the aspect ratio of the input signal.
	4		SQUEEZE, LETTER BOX, <b>EDGE CROP</b>

#### Notes

- IP-RET1, IP-RET2, IP-RET3, IP-RET4 can be selected on the HDCU5000/5500 when HKCU-SFP50 is installed.
- IP-RET1, IP-RET2, IP-RET3 can be selected on the HDCU3500 when HKCU-SFP50 is installed. IP-RET4 can be selected when the HZCU-UHD35 option is enabled.
- UHD-SDI G and UHD-SDI H can be selected on the HDCU5000 when HKCU-SDI50 is installed.

SYSTEM CONFIG			
Page name Page No.	Item	Set value	Description
<RETURN FORMAT2> S14	SDI-I/O		
	1	1080/59.94P, 1080/50P,	Sets the format of the return signal to be input to the SDI I/O connectors.
	2	<b>1080/59.94I(PsF)</b> , 50I(PsF),	
	3	1080/23.98PsF, 24PsF,	
	4	720/59.94P, 50P, 525/59.94I(PsF),	
	625/50I(PsF)		
			<b>Note</b> “DISABLED” is displayed if <VIDEO I/O> → SDI-I/O 1, SDI-I/O 2, SDI-I/O 3, SDI-I/O 4 is set to SDI-RET.
<RETURN FORMAT3> S15 Displayed only for HDCU5000/5500 or HDCU3500 (with HZCU-UHD35 installed).	UHD-SDI		
	C	<b>3840x2160/59.94P/12G</b>	Sets the format of the return signal to be input to the UHD SDI connectors.
	D	3840x2160/29.97P/6G	
	G	3840x2160/23.98P/6G	
	H	3840x2160/50P/12G	
	3840x2160/25P/6G 3840x2160/24P/6G		
			<b>Notes</b> • “DISABLED” is displayed if <VIDEO I/O> → UHD-SDI C, UHD-SDI D is set to SDI-RET. • UHD-SDI G and UHD-SDI H are displayed only when HKCU-SDI50 is installed on the HDCU5000.
<RETURN FORMAT IP> S16 Displayed only when HKCU-SFP50 is installed.	IP-RET		
	1	IP-RET1,2	Sets the format of the return signal to be input on the LAN 1 and LAN 2 connectors.
	2	1080/59.94P, 1080/50P,	
	3	<b>1080/59.94I</b> , 1080/50I	
	4	IP-RET3	
	1080/59.94I(PsF), 1080/50I(PsF) IP-RET4 3840x2160/59.94P/12G, 3840x2160/50P/12G		





## Return format (when FIBER TRANSMIT RATE is set to HIGH and SYSTEM is set to 1.001(525))

### Note

UHD-SDI A and UHD-SDI B are dedicated output connectors, and a return format cannot be configured.

CAMERA FORMAT	SYSTEM CONFIG → <RETURN FORMAT3>	SYSTEM CONFIG → <RETURN FORMAT1>	SYSTEM CONFIG → <RETURN FORMAT2>	SYSTEM CONFIG → <RETURN FORMAT IP>
	UHD-SDI C, UHD-SDI D	SDI-RET1, SDI-RET2, SDI-RET3, SDI-RET4	SDI-I/O1, SDI-I/O2, SDI-I/O3, SDI-I/O4	IP-RET1, IP-RET2, IP-RET3, IP-RET4
UHD/59.94P (4K/HDR)	3840×2160/59.94P/12G	1080/59.94P/3G 1080/59.94I(PsF) 720/59.94P *1 525/59.94I(PsF)	1080/59.94P/3G 1080/59.94I(PsF) 720/59.94P *1 525/59.94I(PsF)	3840×2160/59.94P/12G (IP-RET4 only) 1080/59.94P/3G (IP-RET1, IP-RET2 only) 1080/59.94I (IP-RET1, IP-RET2, IP-RET3 only)
1080/59.94P (4K/HDR)	3840×2160/59.94P/12G	1080/59.94P/3G 1080/59.94I(PsF) 720/59.94P *1 525/59.94I(PsF)	1080/59.94P/3G 1080/59.94I(PsF) 720/59.94P *1 525/59.94I(PsF)	3840×2160/59.94P/12G (IP-RET4 only) 1080/59.94P/3G (IP-RET1, IP-RET2 only) 1080/59.94I (IP-RET1, IP-RET2, IP-RET3 only)
1080/59.94P	–	1080/59.94P/3G 1080/59.94I(PsF) 720/59.94P *1 525/59.94I(PsF)	1080/59.94P/3G 1080/59.94I(PsF) 720/59.94P *1 525/59.94I(PsF)	1080/59.94P/3G (IP-RET1, IP-RET2 only) 1080/59.94I (IP-RET1, IP-RET2, IP-RET3 only)
1080/59.94I	–	1080/59.94I(PsF) 525/59.94I(PsF)	1080/59.94I(PsF) 525/59.94I(PsF)	1080/59.94I (IP-RET1, IP-RET2, IP-RET3 only)
1080/29.97PsF	–	1080/59.94I(PsF) 525/59.94I(PsF)	1080/59.94I(PsF) 525/59.94I(PsF)	–
1080/23.98PsF	–	1080/59.94I(PsF) 1080/23.98PsF 525/59.94I(PsF)	1080/59.94I(PsF) 1080/23.98PsF 525/59.94I(PsF)	–
720/59.94P	–	720/59.94P 525/59.94I(PsF)	720/59.94P 525/59.94I(PsF)	–
1080/ 59.94I(RGB444)	–	1080/59.94I(PsF)/RGB444/3G 1080/59.94I(PsF) 525/59.94I(PsF)	1080/59.94I(PsF)/RGB444/3G 1080/59.94I(PsF) 525/59.94I(PsF)	1080/59.94I (IP-RET1, IP-RET2, IP-RET3 only)
1080/ 29.97PsF(RGB444)	–	1080/59.94I(PsF)/RGB444/3G 1080/59.94I(PsF) 525/59.94I(PsF)	1080/59.94I(PsF)/RGB444/3G 1080/59.94I(PsF) 525/59.94I(PsF)	–
1080/ 23.98PsF(RGB444)	–	1080/23.98PsF/RGB444/3G 1080/59.94I(PsF) 1080/23.98PsF 525/59.94I(PsF)	1080/23.98PsF/RGB444/3G 1080/59.94I(PsF) 1080/23.98PsF 525/59.94I(PsF)	–
1080/59.94I(2x)	–	1080/59.94I(PsF) 525/59.94I(PsF)	1080/59.94I(PsF) 525/59.94I(PsF)	–
720/59.94P(2x)	–	720/59.94P 525/59.94I(PsF)	720/59.94P 525/59.94I(PsF)	–

\*1 720 input can be selected when CCU VIDEO CONVERT is set to ENABLE.

## Return format (when FIBER TRANSMIT RATE is set to HIGH and SYSTEM is set to 1.000(625))

### Note

UHD-SDI A and UHD-SDI B are dedicated output connectors, and a return format cannot be configured.

CAMERA FORMAT	SYSTEM CONFIG → <RETURN FORMAT3>	SYSTEM CONFIG → <RETURN FORMAT1>	SYSTEM CONFIG → <RETURN FORMAT2>	SYSTEM CONFIG → <RETURN FORMAT IP>
	UHD-SDI C, UHD-SDI D	SDI-RET1, SDI-RET2, SDI-RET3, SDI-RET4	SDI-I/O1, SDI-I/O2, SDI-I/O3, SDI-I/O4	IP-RET1, IP-RET2, IP-RET3, IP-RET4
UHD/50P (4K/HDR)	3840×2160/50P/12G	1080/50P/3G 1080/50I(PsF) 720/50P *1 625/50I(PsF)	1080/50P/3G 1080/50I(PsF) 720/50P *1 625/50I(PsF)	3840×2160/50P/12G (IP-RET4 only) 1080/50P/3G (IP-RET1, IP-RET2 only) 1080/50I (IP-RET1, IP-RET2, IP-RET3 only)
1080/50P (4K/HDR)	3840×2160/50P/12G	1080/50P/3G 1080/50I(PsF) 720/50P *1 625/50I(PsF)	1080/50P/3G 1080/50I(PsF) 720/50P *1 625/50I(PsF)	3840×2160/50P/12G (IP-RET4 only) 1080/50P/3G (IP-RET1, IP-RET2 only) 1080/50I (IP-RET1, IP-RET2, IP-RET3 only)
1080/50P	–	1080/50P/3G 1080/50I(PsF) 720/50P *1 625/50I(PsF)	1080/50P/3G 1080/50I(PsF) 720/50P *1 625/50I(PsF)	1080/50P/3G (IP-RET1, IP-RET2 only) 1080/50I (IP-RET1, IP-RET2, IP-RET3 only)
1080/50I	–	1080/50I(PsF) 625/50I(PsF)	1080/50I(PsF) 625/50I(PsF)	1080/50I (IP-RET1, IP-RET2, IP-RET3 only)
1080/25PsF	–	1080/50I(PsF) 625/50I(PsF)	1080/50I(PsF) 625/50I(PsF)	–
1080/24PsF	–	1080/50I(PsF) 1080/24PsF 625/50I(PsF)	1080/50I(PsF) 1080/24PsF 625/50I(PsF)	–
720/50P	–	720/50P 625/50I(PsF)	720/50P 625/50I(PsF)	–
1080/50I(RGB444)	–	1080/50I(PsF)/RGB444/3G 1080/50I(PsF) 625/50I(PsF)	1080/50I(PsF)/RGB444/3G 1080/50I(PsF) 625/50I(PsF)	1080/50I (IP-RET1, IP-RET2, IP-RET3 only)
1080/ 25PsF(RGB444)	–	1080/50I(PsF)/RGB444/3G 1080/50I(PsF) 625/50I(PsF)	1080/50I(PsF)/RGB444/3G 1080/50I(PsF) 625/50I(PsF)	–
1080/ 24PsF(RGB444)	–	1080/24PsF/RGB444/3G 1080/50I(PsF) 1080/24PsF 625/50I(PsF)	1080/24PsF/RGB444/3G 1080/50I(PsF) 1080/24PsF 625/50I(PsF)	–
1080/50I(2x)	–	1080/50I(PsF) 625/50I(PsF)	1080/50I(PsF) 625/50I(PsF)	–
720/50P(2x)	–	720/50P 625/50I(PsF)	720/50P 625/50I(PsF)	–

\*1 720 input can be selected when CCU VIDEO CONVERT is set to ENABLE.

## Return format (when FIBER TRANSMIT RATE is set to ULTRA and SYSTEM is set to 1.001(525))

### Note

UHD-SDI A and UHD-SDI B are dedicated output connectors, and a return format cannot be configured.

CAMERA FORMAT	SYSTEM CONFIG → <RETURN FORMAT3>	SYSTEM CONFIG → <RETURN FORMAT1>	SYSTEM CONFIG → <RETURN FORMAT2>	SYSTEM CONFIG → <RETURN FORMAT IP>
	UHD-SDI C, UHD-SDI D, UHD-SDI G <sup>*1</sup> , UHD-SDI H <sup>*1</sup>	SDI-RET1, SDI-RET2, SDI-RET3, SDI-RET4	SDI-I/O1, SDI-I/O2, SDI-I/O3, SDI-I/O4	IP-RET1, IP-RET2, IP-RET3, IP-RET4
3840×2160/ 59.94P(2x) (HDR/SDR)	3840×2160/59.94P/12G	1080/59.94P/3G 1080/59.94I(PsF) 720/59.94P <sup>*2</sup>	1080/59.94P/3G 1080/59.94I(PsF) 720/59.94P <sup>*2</sup>	3840×2160/59.94P/12G (IP-RET4 only) 1080/59.94P/3G (IP-RET1, IP-RET2 only)
3840×2160/ 59.94P (HDR/SDR)		525/59.94I(PsF)	525/59.94I(PsF)	1080/59.94I (IP-RET1, IP-RET2, IP-RET3 only)
3840×2160/ 29.97P (HDR/SDR)	3840×2160/29.97P/6G	1080/59.94I(PsF) 525/59.94I(PsF)	1080/59.94I(PsF) 525/59.94I(PsF)	–
3840×2160/ 23.98P (HDR/SDR)	3840×2160/23.98P/6G	1080/59.94I(PsF) 1080/23.98PsF 525/59.94I(PsF)	1080/59.94I(PsF) 1080/23.98PsF 525/59.94I(PsF)	–
1080/59.94P (HDR/SDR)	–	1080/59.94P/3G 1080/59.94I(PsF) 720/59.94P <sup>*2</sup> 525/59.94I(PsF)	1080/59.94P/3G 1080/59.94I(PsF) 720/59.94P <sup>*2</sup> 525/59.94I(PsF)	1080/59.94P/3G (IP-RET1, IP-RET2 only) 1080/59.94I (IP-RET3 only)
1080/29.97PsF (HDR/SDR)	–	1080/59.94I(PsF) 525/59.94I(PsF)	1080/59.94I(PsF) 525/59.94I(PsF)	–
1080/23.98PsF (HDR/SDR)	–	1080/59.94I(PsF) 1080/23.98PsF 525/59.94I(PsF)	1080/59.94I(PsF) 1080/23.98PsF 525/59.94I(PsF)	–
1080/ 59.94I(RGB444) (SDR)	–	1080/59.94I(PsF)/RGB444/3G 1080/59.94I(PsF) 525/59.94I(PsF)	1080/59.94I(PsF)/RGB444/3G 1080/59.94I(PsF) 525/59.94I(PsF)	1080/59.94I (IP-RET1, IP-RET2, IP-RET3 only)
1080/ 29.97PsF(RGB444) (SDR)	–	1080/59.94I(PsF)/RGB444/3G 1080/59.94I(PsF) 525/59.94I(PsF)	1080/59.94I(PsF)/RGB444/3G 1080/59.94I(PsF) 525/59.94I(PsF)	–
1080/ 23.98PsF(RGB444) (SDR)	–	1080/23.98PsF/RGB444/3G 1080/59.94I(PsF) 1080/23.98PsF 525/59.94I(PsF)	1080/23.98PsF/RGB444/3G 1080/59.94I(PsF) 1080/23.98PsF 525/59.94I(PsF)	–
1080/59.94P(2x) (HDR/SDR)	–	1080/59.94P/3G 1080/59.94I(PsF) 720/59.94P <sup>*3</sup> 525/59.94I(PsF)	1080/59.94P/3G 1080/59.94I(PsF) 720/59.94P <sup>*3</sup> 525/59.94I(PsF)	–
1080/59.94P(3x) (HDR/SDR)	–	1080/59.94P/3G 1080/59.94I(PsF) 720/59.94P <sup>*3</sup> 525/59.94I(PsF)	1080/59.94P/3G 1080/59.94I(PsF) 720/59.94P <sup>*3</sup> 525/59.94I(PsF)	–
1080/59.94P(4x) (HDR/SDR)	–	1080/59.94P/3G 1080/59.94I(PsF) 720/59.94P <sup>*3</sup> 525/59.94I(PsF)	1080/59.94P/3G 1080/59.94I(PsF) 720/59.94P <sup>*3</sup> 525/59.94I(PsF)	–

CAMERA FORMAT	SYSTEM CONFIG → <RETURN FORMAT3>	SYSTEM CONFIG → <RETURN FORMAT1>	SYSTEM CONFIG → <RETURN FORMAT2>	SYSTEM CONFIG → <RETURN FORMAT IP>
	UHD-SDI C, UHD-SDI D, UHD-SDI G <sup>*1</sup> , UHD-SDI H <sup>*1</sup>	SDI-RET1, SDI-RET2, SDI-RET3, SDI-RET4	SDI-I/O1, SDI-I/O2, SDI-I/O3, SDI-I/O4	IP-RET1, IP-RET2, IP-RET3, IP-RET4
1080/59.94P(6x) (HDR/SDR)	–	1080/59.94P/3G 1080/59.94I(PsF) 720/59.94P <sup>*3</sup> 525/59.94I(PsF)	1080/59.94P/3G 1080/59.94I(PsF) 720/59.94P <sup>*3</sup> 525/59.94I(PsF)	–
1080/59.94P(8x) (HDR/SDR)	–	1080/59.94P/3G 1080/59.94I(PsF) 720/59.94P <sup>*3</sup> 525/59.94I(PsF)	1080/59.94P/3G 1080/59.94I(PsF) 720/59.94P <sup>*3</sup> 525/59.94I(PsF)	–

\*1 Configurable only on HDCU5000 when HKCU-SDI50 is installed.

\*2 720 input can be selected when CCU VIDEO CONVERT is set to ENABLE.

\*3 720 input can be selected when both CCU VIDEO CONVERT is set to ENABLE and the HDR mode of the connected camera is set to OFF.

## Return format (when FIBER TRANSMIT RATE is set to ULTRA and SYSTEM is set to 1.000(625))

### Note

UHD-SDI A and UHD-SDI B are dedicated output connectors, and a return format cannot be configured.

CAMERA FORMAT	SYSTEM CONFIG → <RETURN FORMAT3>	SYSTEM CONFIG → <RETURN FORMAT1>	SYSTEM CONFIG → <RETURN FORMAT2>	SYSTEM CONFIG → <RETURN FORMAT IP>
	UHD-SDI C, UHD-SDI D, UHD-SDI G <sup>*1</sup> , UHD-SDI H <sup>*1</sup>	SDI-RET1, SDI-RET2, SDI-RET3, SDI-RET4	SDI-I/O1, SDI-I/O2, SDI-I/O3, SDI-I/O4	IP-RET1, IP-RET2, IP-RET3, IP-RET4
3840x2160/ 50P(2x) (HDR/SDR) 3840x2160/50P (HDR/SDR)	3840x2160/50P/12G	1080/50P/3G 1080/50I(PsF) 720/50P <sup>*2</sup> 625/50I(PsF)	1080/50P/3G 1080/50I(PsF) 720/50P <sup>*2</sup> 625/50I(PsF)	3840x2160/50P/12G (IP-RET4 only) 1080/50P/3G (IP-RET1, IP-RET2 only) 1080/50I (IP-RET1, IP-RET2, IP-RET3 only)
3840x2160/25P (HDR/SDR)	3840x2160/25P/6G	1080/50I(PsF) 625/50I(PsF)	1080/50I(PsF) 625/50I(PsF)	–
3840x2160/24P (HDR/SDR)	3840x2160/24P/6G	1080/50I(PsF) 1080/24PsF 625/50I(PsF)	1080/50I(PsF) 1080/24PsF 625/50I(PsF)	–
1080/50P (HDR/SDR)	–	1080/50P/3G 1080/50I(PsF) 720/50P <sup>*2</sup> 625/50I(PsF)	1080/50P/3G 1080/50I(PsF) 720/50P <sup>*2</sup> 625/50I(PsF)	1080/50P/3G (IP-RET1, IP-RET2 only) 1080/50I (IP-RET3 only)
1080/25PsF (HDR/SDR)	–	1080/50I(PsF) 625/50I(PsF)	1080/50I(PsF) 625/50I(PsF)	–
1080/24PsF (HDR/SDR)	–	1080/50I(PsF) 1080/24PsF 625/50I(PsF)	1080/50I(PsF) 1080/24PsF 625/50I(PsF)	–
1080/50I(RGB444) (SDR)	–	1080/50I(PsF)/RGB444/3G 1080/50I(PsF) 625/50I(PsF)	1080/50I(PsF)/RGB444/3G 1080/50I(PsF) 625/50I(PsF)	1080/50I (IP-RET1, IP-RET2, IP-RET3 only)
1080/ 25PsF(RGB444) (SDR)	–	1080/50I(PsF)/RGB444/3G 1080/50I(PsF) 625/50I(PsF)	1080/50I(PsF)/RGB444/3G 1080/50I(PsF) 625/50I(PsF)	–
1080/ 24PsF(RGB444) (SDR)	–	1080/24PsF/RGB444/3G 1080/50I(PsF) 1080/24PsF 625/50I(PsF)	1080/24PsF/RGB444/3G 1080/50I(PsF) 1080/24PsF 625/50I(PsF)	–
1080/50P(2x) (HDR/SDR)	–	1080/50P/3G 1080/50I(PsF) 720/50P <sup>*3</sup> 625/50I(PsF)	1080/50P/3G 1080/50I(PsF) 720/50P <sup>*3</sup> 625/50I(PsF)	–

CAMERA FORMAT	SYSTEM CONFIG → <RETURN FORMAT3>	SYSTEM CONFIG → <RETURN FORMAT1>	SYSTEM CONFIG → <RETURN FORMAT2>	SYSTEM CONFIG → <RETURN FORMAT IP>
	UHD-SDI C, UHD-SDI D, UHD-SDI G <sup>*1</sup> , UHD-SDI H <sup>*1</sup>	SDI-RET1, SDI-RET2, SDI-RET3, SDI-RET4	SDI-I/O1, SDI-I/O2, SDI-I/O3, SDI-I/O4	IP-RET1, IP-RET2, IP-RET3, IP-RET4
1080/50P(3×) (HDR/SDR)	–	1080/50P/3G 1080/50I(PsF) 720/50P <sup>*3</sup> 625/50I(PsF)	1080/50P/3G 1080/50I(PsF) 720/50P <sup>*3</sup> 625/50I(PsF)	–
1080/50P(4×) (HDR/SDR)	–	1080/50P/3G 1080/50I(PsF) 720/50P <sup>*3</sup> 625/50I(PsF)	1080/50P/3G 1080/50I(PsF) 720/50P <sup>*3</sup> 625/50I(PsF)	–
1080/50P(6×) (HDR/SDR)	–	1080/50P/3G 1080/50I(PsF) 720/50P <sup>*3</sup> 625/50I(PsF)	1080/50P/3G 1080/50I(PsF) 720/50P <sup>*3</sup> 625/50I(PsF)	–
1080/50P(8×) (HDR/SDR)	–	1080/50P/3G 1080/50I(PsF) 720/50P <sup>*3</sup> 625/50I(PsF)	1080/50P/3G 1080/50I(PsF) 720/50P <sup>*3</sup> 625/50I(PsF)	–

\*1 Configurable only on HDCU5000 when HKCU-SDI50 is installed.

\*2 720 input can be selected when CCU VIDEO CONVERT is set to ENABLE.

\*3 720 input can be selected when both CCU VIDEO CONVERT is set to ENABLE and the HDR mode of the connected camera is set to OFF.

**Formats settable for UHD SDI, SDI OUT, SDI I/O, and IP OUT connectors (when FIBER TRANSMIT RATE is set to HIGH and SYSTEM is set to 1.001(525))**

**Note**

For underlined formats, the mode can be switched between HDR and SDR according to the Live HDR mode setting of the connected camera.

CAMERA FORMAT	SYSTEM CONFIG → <OUTPUT FORMAT3> or SYSTEM CONFIG → <OUTPUT FORMAT4>	SYSTEM CONFIG → <OUTPUT FORMAT1>	SYSTEM CONFIG → <OUTPUT FORMAT2>	SYSTEM CONFIG → <OUTPUT FORMAT IP>
	<OUTPUT FORMAT3>: UHD-SDI A, UHD-SDI B, UHD-SDI C, UHD-SDI D <OUTPUT FORMAT4>: UHD-SDI E <sup>*1</sup> , UHD-SDI F <sup>*1</sup> , UHD-SDI G <sup>*1</sup> , UHD-SDI H <sup>*1</sup>	SDI-OUT1, SDI-OUT2, SDI-OUT3, SDI-OUT4	SDI-I/O1, SDI-I/O2, SDI-I/O3, SDI-I/O4	IP-OUT1 <sup>*2</sup> , IP-OUT2 <sup>*2</sup> , IP-OUT3 <sup>*2</sup> , IP-OUT4 <sup>*2</sup>
<u>UHD/59.94P</u> <u>(4K/HDR)</u> or <u>1080/59.94P</u> <u>(4K/HDR)</u>	<u>3840x2160/59.94P/12G</u> <u>3840x2160/59.94P/SQD/</u> <u>3G-A</u> <u>3840x2160/59.94P/SQD/</u> <u>3G-B</u> <u>3840x2160/59.94P/2SI/3G-A</u> <u>3840x2160/59.94P/2SI/3G-B</u> <u>1080/59.94P/3G-A</u> <u>1080/59.94P/3G-B</u> <u>1080/59.94I</u>	<For SDI-OUT1, SDI-OUT2> <u>3840x2160/59.94P/SQD/</u> <u>3G-A</u> <u>3840x2160/59.94P/SQD/</u> <u>3G-B</u> <u>3840x2160/59.94P/2SI/3G-A</u> <u>3840x2160/59.94P/2SI/3G-B</u> <u>1080/59.94P/3G-A</u> <u>1080/59.94P/3G-B</u> <u>1080/59.94I</u> <u>720/59.94P<sup>*3</sup></u> <u>525/59.94I</u>	<For SDI I/O1, SDI I/O2> <u>3840x2160/59.94P/SQD/</u> <u>3G-A</u> <u>3840x2160/59.94P/SQD/</u> <u>3G-B</u> <u>3840x2160/59.94P/2SI/3G-A</u> <u>3840x2160/59.94P/2SI/3G-B</u> <u>1080/59.94P/3G-A</u> <u>1080/59.94P/3G-B</u> <u>1080/59.94I</u> <u>720/59.94P<sup>*3</sup></u> <u>525/59.94I</u>	<For IP-OUT1, IP-OUT2> <u>1080/59.94P/3G-A</u> <u>1080/59.94P/3G-A</u> <u>1080/59.94I</u> <For IP-OUT3> <u>1080/59.94I</u> <For IP-OUT4> <u>3840x2160/59.94P/12G</u>
	<b>Notes</b>	<b>Note</b>	<b>Note</b>	
	<ul style="list-style-type: none"> <li>HZCU-UHD35 is required for 4K output.</li> <li>The UHD-SDI B, UHD-SDI C, UHD-SDI D, UHD-SDI E, UHD-SDI F, UHD-SDI G, and UHD-SDI H settings are linked to the UHD SDI A setting.</li> </ul>	<p>HZCU-UHD35 is required for 4K output.</p> <p>&lt;For SDI-OUT3, SDI-OUT4&gt; <u>1080/59.94P/3G-A</u> <u>1080/59.94P/3G-B</u> <u>1080/59.94I</u> <u>720/59.94P<sup>*3</sup></u> <u>525/59.94I</u></p>	<p>The format setting is linked to the SDI-OUT1 settings when SDI-OUT1 is set for 4K output.</p> <p>&lt;For SDI I/O3, SDI I/O4&gt; <u>1080/59.94P/3G-A</u> <u>1080/59.94P/3G-B</u> <u>1080/59.94I</u> <u>720/59.94P<sup>*3</sup></u> <u>525/59.94I</u></p>	
1080/59.94P	1080/59.94P/3G-A 1080/59.94P/3G-B 1080/59.94I	1080/59.94P/3G-A 1080/59.94P/3G-B 1080/59.94I 720/59.94P <sup>*3</sup> 525/59.94I	1080/59.94P/3G-A 1080/59.94P/3G-B 1080/59.94I 720/59.94P <sup>*3</sup> 525/59.94I	1080/59.94P/3G-A (IP-OUT1, IP-OUT2 only) 1080/59.94I (IP-OUT1, IP-OUT2, IP-OUT3 only)
1080/59.94I	1080/59.94I	1080/59.94I 525/59.94I	1080/59.94I 525/59.94I	1080/59.94I (IP-OUT1, IP-OUT2, IP-OUT3 only)
1080/29.97PsF	1080/29.97PsF	1080/29.97PsF 525/29.97PsF	1080/29.97PsF 525/29.97PsF	–
1080/23.98PsF	1080/23.98PsF	1080/23.98PsF 1080/59.94I 525/59.94I	1080/23.98PsF 1080/59.94I 525/59.94I	–
720/59.94P	720/59.94P	720/59.94P 525/59.94I	720/59.94P 525/59.94I	–
1080/ 59.94I(RGB444)	1080/59.94I(RGB444)/3G-B 1080/59.94I	1080/59.94I(RGB444)/3G-B 1080/59.94I 525/59.94I	1080/59.94I(RGB444)/3G-B 1080/59.94I 525/59.94I	1080/59.94I

CAMERA FORMAT	SYSTEM CONFIG → <OUTPUT FORMAT3> or SYSTEM CONFIG → <OUTPUT FORMAT4>	SYSTEM CONFIG → <OUTPUT FORMAT1>	SYSTEM CONFIG → <OUTPUT FORMAT2>	SYSTEM CONFIG → <OUTPUT FORMAT IP>
	<OUTPUT FORMAT3>: UHD-SDI A, UHD-SDI B, UHD-SDI C, UHD-SDI D <OUTPUT FORMAT4>: UHD-SDI E <sup>*1</sup> , UHD-SDI F <sup>*1</sup> , UHD-SDI G <sup>*1</sup> , UHD-SDI H <sup>*1</sup>	SDI-OUT1, SDI-OUT2, SDI-OUT3, SDI-OUT4	SDI-I/O1, SDI-I/O2, SDI-I/O3, SDI-I/O4	IP-OUT1 <sup>*2</sup> , IP-OUT2 <sup>*2</sup> , IP-OUT3 <sup>*2</sup> , IP-OUT4 <sup>*2</sup>
1080/ 29.97PsF(RGB444)	1080/29.97PsF(RGB444)/ 3G-B 1080/29.97PsF	1080/29.97PsF(RGB444)/ 3G-B 1080/29.97PsF 525/29.97PsF	1080/29.97PsF(RGB444)/ 3G-B 1080/29.97PsF 525/29.97PsF	–
1080/ 23.98PsF(RGB444)	1080/23.98PsF(RGB444)/ 3G-B 1080/23.98PsF	1080/23.98PsF(RGB444)/ 3G-B 1080/23.98PsF 1080/59.94I 525/59.94I	1080/23.98PsF(RGB444)/ 3G-B 1080/23.98PsF 1080/59.94I 525/59.94I	–
1080/59.94I(2x)	1080/59.94I(2x)/3G-B/ Link1&Link2 1080/59.94I	<For SDI-OUT1, SDI-OUT3> 1080/59.94I(2x)/Link1 1080/59.94I(2x)/3G-B/ Link1&Link2 1080/59.94I 525/59.94I  <For SDI-OUT2, SDI-OUT4> 1080/59.94I(2x)/Link2 1080/59.94I(2x)/3G-B/ Link1&Link2 1080/59.94I 525/59.94I	<For SDI I/O1, SDI I/O3> 1080/59.94I(2x)/Link1 1080/59.94I(2x)/3G-B/ Link1&Link2 1080/59.94I 525/59.94I  <For SDI I/O2, SDI I/O4> 1080/59.94I(2x)/Link2 1080/59.94I(2x)/3G-B/ Link1&Link2 1080/59.94I 525/59.94I	–
720/59.94P(2x)	720/59.94P(2x)/3G-B/ Link1&Link2 720/59.94P	<For SDI-OUT1, SDI-OUT3> 720/59.94P(2x)/Link1 720/59.94P(2x)/3G-B/ Link1&Link2 720/59.94P 525/59.94I  <For SDI-OUT2, SDI-OUT4> 720/59.94P(2x)/Link2 720/59.94P(2x)/3G-B/ Link1&Link2 720/59.94P 525/59.94I	<For SDI I/O1, SDI I/O3> 720/59.94P(2x)/Link1 720/59.94P(2x)/3G-B/ Link1&Link2 720/59.94P 525/59.94I  <For SDI I/O2, SDI I/O4> 720/59.94P(2x)/Link2 720/59.94P(2x)/3G-B/ Link1&Link2 720/59.94P 525/59.94I	–

\*1 Configurable only on HDCU5000 when HKCU-SDI50 is installed.

\*2 Configurable only when the HKCU-SFP50 is installed.

\*3 720 output can be selected when CCU VIDEO CONVERT is set to ENABLE.

**Formats settable for UHD SDI, SDI OUT, SDI I/O, and IP OUT connectors (when FIBER TRANSMIT RATE is set to HIGH and SYSTEM is set to 1.000(625))**

**Note**

For underlined formats, the mode can be switched between HDR and SDR according to the Live HDR mode setting of the connected camera.

CAMERA FORMAT	SYSTEM CONFIG → <OUTPUT FORMAT3> or SYSTEM CONFIG → <OUTPUT FORMAT4>	SYSTEM CONFIG → <OUTPUT FORMAT1>	SYSTEM CONFIG → <OUTPUT FORMAT2>	SYSTEM CONFIG → <OUTPUT FORMAT IP>
<u>UHD/50P (4K/HDR)</u> or <u>1080/50P (4K/HDR)</u>	<OUTPUT FORMAT3>: UHD-SDI A, UHD-SDI B, UHD-SDI C, UHD-SDI D <OUTPUT FORMAT4>: UHD-SDI E <sup>*1</sup> , UHD-SDI F <sup>*1</sup> , UHD-SDI G <sup>*1</sup> , UHD-SDI H <sup>*1</sup>	SDI-OUT1, SDI-OUT2, SDI-OUT3, SDI-OUT4	SDI-I/O1, SDI-I/O2, SDI-I/O3, SDI-I/O4	IP-OUT1 <sup>*2</sup> , IP-OUT2 <sup>*2</sup> , IP-OUT3 <sup>*2</sup> , IP-OUT4 <sup>*2</sup>
		<For SDI-OUT1, SDI-OUT2>	<For SDI I/O1, SDI I/O2>	<For IP-OUT1, IP-OUT2>
		3840x2160/50P/SQD/3G-A	3840x2160/50P/SQD/ 3G-A	1080/50P/3G-A
		3840x2160/50P/SQD/3G-B	3840x2160/50P/SQD/ 3G-B	1080/50P/3G-A
		3840x2160/50P/2SI/3G-A	3840x2160/50P/2SI/3G-A	1080/50I
		3840x2160/50P/2SI/3G-B	3840x2160/50P/2SI/3G-B	<For IP-OUT3>
		1080/50P/3G-A	1080/50P/3G-A	1080/50I
		1080/50P/3G-B	1080/50P/3G-B	<For IP-OUT4>
		1080/50I	1080/50P/3G-A	3840x2160/50P/12G
		720/50P <sup>*3</sup>	1080/50P/3G-B	
		625/50I	1080/50I	
			720/50P <sup>*3</sup>	
			625/50I	
	<b>Notes</b>			
	• HZCU-UHD35 is required for 4K output.			
	• The UHD-SDI B, UHD-SDI C, UHD-SDI D, UHD-SDI E, UHD-SDI F, UHD-SDI G, and UHD-SDI H settings are linked to the UHD SDI A setting.			
		<b>Note</b>		
		HZCU-UHD35 is required for 4K output.		
		<For SDI-OUT3, SDI-OUT4>		
		1080/50P/3G-A		
		1080/50P/3G-B		
		1080/50I		
		720/50P <sup>*3</sup>		
		625/50I		
			<b>Note</b>	
			The format setting is linked to the SDI-OUT1 settings when SDI-OUT1 is set for 4K output.	
			<For SDI I/O3, SDI I/O4>	
			1080/50P/3G-A	
			1080/50P/3G-B	
			1080/50I	
			720/50P <sup>*3</sup>	
			625/50I	
1080/50P	1080/50P/3G-A 1080/50P/3G-B 1080/50I	1080/50P/3G-A 1080/50P/3G-B 1080/50I 720/50P <sup>*3</sup> 625/50i	1080/50P/3G-A 1080/50P/3G-B 1080/50I 720/50P <sup>*3</sup> 625/50I	1080/50P/3G-A (IP-OUT1, IP-OUT2 only) 1080/50I (IP-OUT1, IP-OUT2, IP-OUT3 only)
1080/50I	1080/50I	1080/50I 625/50I	1080/50I 625/50I	1080/50I (IP-OUT1, IP-OUT2, IP-OUT3 only)
1080/25PsF	1080/25PsF	1080/25PsF 625/25PsF	1080/25PsF 625/25PsF	–
1080/24PsF	1080/24PsF	1080/24PsF 1080/50I 625/50I	1080/24PsF 1080/50I 625/50I	–
720/50P	720/50P	720/50P 625/50I	720/50P 625/50I	–
1080/50I(RGB444)	1080/50I(RGB444)/3G-B 1080/50I	1080/50I(RGB444)/3G-B 1080/50I 625/50I	1080/50I(RGB444)/3G-B 1080/50I 625/50I	1080/50I



CAMERA FORMAT	SYSTEM CONFIG → <OUTPUT FORMAT3> or SYSTEM CONFIG → <OUTPUT FORMAT4>	SYSTEM CONFIG → <OUTPUT FORMAT1>	SYSTEM CONFIG → <OUTPUT FORMAT2>	SYSTEM CONFIG → <OUTPUT FORMAT IP>
	<OUTPUT FORMAT3>: UHD-SDI A, UHD-SDI B, UHD-SDI C, UHD-SDI D <OUTPUT FORMAT4>: UHD-SDI E <sup>*1</sup> , UHD-SDI F <sup>*1</sup> , UHD-SDI G <sup>*1</sup> , UHD-SDI H <sup>*1</sup>	SDI-OUT1, SDI-OUT2, SDI-OUT3, SDI-OUT4	SDI-I/O1, SDI-I/O2, SDI-I/O3, SDI-I/O4	IP-OUT1 <sup>*2</sup> , IP-OUT2 <sup>*2</sup> , IP-OUT3 <sup>*2</sup> , IP-OUT4 <sup>*2</sup>
1080/ 25PsF(RGB444)	1080/25PsF(RGB444)/3G-B 1080/25PsF	1080/25PsF(RGB444)/3G-B 1080/25PsF 625/25PsF	1080/25PsF(RGB444)/3G-B 1080/25PsF 625/25PsF	–
1080/ 24PsF(RGB444)	1080/24PsF(RGB444)/3G-B 1080/24PsF	1080/24PsF(RGB444)/3G-B 1080/24PsF 1080/50I 625/50I	1080/24PsF(RGB444)/3G-B 1080/24PsF 1080/50I 625/50I	–
1080/50I(2x)	1080/50I(2x)/3G-B/ Link1&Link2 1080/50I	<For SDI-OUT1, SDI-OUT3> 1080/50I(2x)/Link1 1080/50I(2x)/3G-B/ Link1&Link2 1080/50I 625/50I  <For SDI-OUT2, SDI-OUT4> 1080/50I(2x)/Link2 1080/50I(2x)/3G-B/ Link1&Link2 1080/50I 625/50I	<For SDI I/O1, SDI I/O3> 1080/50I(2x)/Link1 1080/50I(2x)/3G-B/ Link1&Link2 1080/50I 625/50I  <For SDI I/O2, SDI I/O4> 1080/50I(2x)/Link2 1080/50I(2x)/3G-B/ Link1&Link2 1080/50I 625/50I	–
720/50P(2x)	720/50P(2x)/3G-B/ Link1&Link2 720/50P	<For SDI-OUT1, SDI-OUT3> 720/50P(2x)/Link1 720/50P(2x)/3G-B/ Link1&Link2 720/50P 625/50I  <For SDI-OUT2, SDI-OUT4> 720/50P(2x)/Link2 720/50P(2x)/3G-B/ Link1&Link2 720/50P 625/50I	<For SDI I/O1, SDI I/O3> 720/50P(2x)/Link1 720/50P(2x)/3G-B/ Link1&Link2 720/50P 625/50I  <For SDI I/O2, SDI I/O4> 720/50P(2x)/Link2 720/50P(2x)/3G-B/ Link1&Link2 720/50P 625/50I	–

\*1 Configurable only on HDCU5000 when HKCU-SDI50 is installed.

\*2 Configurable only when the HKCU-SFP50 is installed.

\*3 720 output can be selected when CCU VIDEO CONVERT is set to ENABLE.

**Formats settable for UHD SDI, SDI OUT, SDI I/O, and IP OUT connectors (when FIBER TRANSMIT RATE is set to ULTRA and SYSTEM is set to 1.001(525))**

**Note**

For underlined formats, the mode can be switched between HDR and SDR according to the Live HDR mode setting of the connected camera.

CAMERA FORMAT	SYSTEM CONFIG → <OUTPUT FORMAT3> or SYSTEM CONFIG → <OUTPUT FORMAT4>	SYSTEM CONFIG → <OUTPUT FORMAT1>	SYSTEM CONFIG → <OUTPUT FORMAT2>	SYSTEM CONFIG → <OUTPUT FORMAT IP>
	<OUTPUT FORMAT3>: UHD-SDI A, UHD-SDI B, UHD-SDI C, UHD-SDI D <OUTPUT FORMAT4>: UHD-SDI E <sup>*1</sup> , UHD-SDI F <sup>*1</sup> , UHD-SDI G <sup>*1</sup> , UHD-SDI H <sup>*1</sup>	SDI-OUT1, SDI-OUT2, SDI-OUT3, SDI-OUT4	SDI-I/O1, SDI-I/O2, SDI-I/O3, SDI-I/O4	IP-OUT1 <sup>*2</sup> , IP-OUT2 <sup>*2</sup> , IP-OUT3 <sup>*2</sup> , IP-OUT4 <sup>*2</sup>
<u>3840x2160/59.94P(2x)</u> (HDR/SDR)	<u>3840x2160/59.94P/12G</u> <u>3840x2160/59.94P/SQD/3G-A</u>	<u>3840x2160/59.94P/SQD/3G-A</u>	<u>3840x2160/59.94P/SQD/3G-A</u>	<u>3840x2160/59.94P/12G</u> (IP-OUT4 only)
<u>3840x2160/59.94P</u> (HDR/SDR)	<u>3840x2160/59.94P/SQD/3G-B</u> <u>3840x2160/59.94P/2SI/3G-A</u> <u>3840x2160/59.94P/2SI/3G-B</u>	<u>3840x2160/59.94P/SQD/3G-B</u> <u>3840x2160/59.94P/2SI/3G-A</u> <u>3840x2160/59.94P/2SI/3G-B</u>	<u>3840x2160/59.94P/SQD/3G-B</u> <u>3840x2160/59.94P/2SI/3G-A</u> <u>3840x2160/59.94P/2SI/3G-B</u>	<u>1080/59.94I</u> (IP-OUT1, IP-OUT2, IP-OUT3 only) <u>1080/59.94P/3G-A</u> (IP-OUT1, IP-OUT2 only)
	<b>Note</b> The UHD-SDI B, UHD-SDI C, UHD-SDI D, UHD-SDI E, UHD-SDI F, UHD-SDI G, and UHD-SDI H settings are linked to the UHD SDI A setting.	(The 4 formats above for SDI-OUT1, SDI-OUT2 only) <u>1080/59.94I</u> <u>1080/59.94P/3G-A</u> <u>1080/59.94P/3G-B</u> <u>720/59.94P<sup>*3</sup></u> <u>525/59.94I</u>	(The 4 formats above for SDI-I/O1, SDI-I/O2 only) <u>1080/59.94I</u> <u>1080/59.94P/3G-A</u> <u>1080/59.94P/3G-B</u> <u>720/59.94P<sup>*3</sup></u> <u>525/59.94I</u>	
		<b>Note</b> The 4K output settings are linked to the SDI-OUT1 settings.	<b>Note</b> The 4K output settings are linked to the SDI-I/O1 settings.	
<u>3840x2160/29.97P</u> (HDR/SDR)	<u>3840x2160/29.97P/6G</u> <u>3840x2160/29.97PsF/SQD/3G-B</u> <u>3840x2160/29.97P/2SI/3G-B</u> <u>3840x2160/29.97PsF/SQD/1.5G</u>	<u>3840x2160/29.97PsF/SQD/3G-B</u> <u>3840x2160/29.97PsF/SQD/1.5G</u>	<u>3840x2160/29.97PsF/SQD/3G-B</u> <u>3840x2160/29.97PsF/SQD/1.5G</u>	-
		(The 2 formats above for SDI-OUT1, SDI-OUT2 only) <u>1080/29.97PsF</u> <u>525/29.97PsF</u>	(The 2 formats above for SDI-I/O1, SDI-I/O2 only) <u>1080/29.97PsF</u> <u>525/29.97PsF</u>	
		<b>Note</b> The 4K output settings are linked to the SDI-OUT1 settings.	<b>Note</b> The 4K output settings are linked to the SDI-OUT1 settings.	
<u>3840x2160/23.98P</u> (HDR/SDR)	<u>3840x2160/23.98P/6G</u> <u>3840x2160/23.98PsF/SQD/3G-B</u> <u>3840x2160/23.98P/2SI/3G-B</u> <u>3840x2160/23.98PsF/SQD/1.5G</u>	<u>3840x2160/23.98PsF/SQD/3G-B</u> <u>3840x2160/23.98PsF/SQD/1.5G</u>	<u>3840x2160/23.98PsF/SQD/3G-B</u> <u>3840x2160/23.98PsF/SQD/1.5G</u>	-
		(The 2 formats above for SDI-OUT1, SDI-OUT2 only) <u>1080/59.94I</u> <u>1080/23.98PsF</u> <u>525/59.94I</u>	(The 2 formats above for SDI-I/O1, SDI-I/O2 only) <u>1080/59.94I</u> <u>1080/23.98PsF</u> <u>525/59.94I</u>	
		<b>Note</b> The 4K output settings are linked to the SDI-OUT1 settings.	<b>Note</b> The 4K output settings are linked to the SDI-OUT1 settings.	

CAMERA FORMAT	SYSTEM CONFIG → <OUTPUT FORMAT3> or SYSTEM CONFIG → <OUTPUT FORMAT4>	SYSTEM CONFIG → <OUTPUT FORMAT1>	SYSTEM CONFIG → <OUTPUT FORMAT2>	SYSTEM CONFIG → <OUTPUT FORMAT IP>
	<OUTPUT FORMAT3>: UHD-SDI A, UHD-SDI B, UHD-SDI C, UHD-SDI D <OUTPUT FORMAT4>: UHD-SDI E <sup>*1</sup> , UHD-SDI F <sup>*1</sup> , UHD-SDI G <sup>*1</sup> , UHD-SDI H <sup>*1</sup>	SDI-OUT1, SDI-OUT2, SDI-OUT3, SDI-OUT4	SDI-I/O1, SDI-I/O2, SDI-I/O3, SDI-I/O4	IP-OUT1 <sup>*2</sup> , IP-OUT2 <sup>*2</sup> , IP-OUT3 <sup>*2</sup> , IP-OUT4 <sup>*2</sup>
<u>1080/59.94P</u> (HDR/SDR)	<u>1080/59.94I</u> <u>1080/59.94P/3G-A</u> <u>1080/59.94P/3G-B</u>	<u>1080/59.94I</u> <u>1080/59.94P/3G-A</u> <u>1080/59.94P/3G-B</u> 720/59.94P <sup>*3</sup> 525/59.94I	<u>1080/59.94I</u> <u>1080/59.94P/3G-A</u> <u>1080/59.94P/3G-B</u> 720/59.94P <sup>*3</sup> 525/59.94I	<u>1080/59.94P/3G-A</u> (IP-OUT1, IP-OUT2 only) <u>1080/59.94I</u> (IP-OUT1, IP-OUT2, IP-OUT3 only)
<u>1080/29.97PsF</u> (HDR/SDR)	<u>1080/29.97PsF</u>	<u>1080/29.97PsF</u> 525/29.97PsF	<u>1080/29.97PsF</u> 525/29.97PsF	–
<u>1080/23.98PsF</u> (HDR/SDR)	<u>1080/23.98PsF</u>	<u>1080/59.94I</u> <u>1080/23.98PsF</u> 525/59.94I	<u>1080/59.94I</u> <u>1080/23.98PsF</u> 525/59.94I	–
1080/ 59.94I(RGB444) (SDR)	1080/59.94I 1080/59.94I(RGB444)/3G-B	1080/59.94I 1080/59.94I(RGB444)/3G-B 525/59.94I	1080/59.94I 1080/59.94I(RGB444)/3G-B 525/59.94I	1080/59.94I (IP-OUT1, IP-OUT2, IP-OUT3 only)
1080/ 29.97PsF(RGB444) (SDR)	1080/29.97PsF 1080/29.97PsF(RGB444)/ 3G-B	1080/29.97PsF 1080/29.97PsF(RGB444)/ 3G-B 525/29.97PsF	1080/29.97PsF 1080/29.97PsF(RGB444)/ 3G-B 525/29.97PsF	–
1080/ 23.98PsF(RGB444) (SDR)	1080/23.98PsF 1080/23.98PsF(RGB444)/ 3G-B	1080/59.94I 1080/23.98PsF 1080/23.98PsF(RGB444)/ 3G-B 525/59.94I	1080/59.94I 1080/23.98PsF 1080/23.98PsF(RGB444)/ 3G-B 525/59.94I	–
<u>1080/59.94P(2x)</u> (HDR/SDR)	<u>1080/59.94P(2x)/3G-A</u> <u>1080/59.94P(2x)/3G-B</u> <u>1080/59.94P(2x)/12G</u> <u>1080/59.94I(2x)</u> <u>1080/59.94I(2x)/3G-B</u> <u>1080/59.94I(2x)/12G</u> 720/59.94P(2x) <sup>*4</sup> 720/59.94P(2x)/3G-B <sup>*4</sup> 720/59.94P(2x)/12G	<u>1080/59.94P(2x)/3G-A</u> <u>1080/59.94P(2x)/3G-B</u> 720/59.94P(2x) <sup>*4</sup> 720/59.94P(2x)/3G-B <sup>*4</sup> (The 4 formats above for SDI-OUT1, SDI-OUT2 only) <u>1080/59.94I</u> <u>1080/59.94P/3G-A</u> <u>1080/59.94P/3G-B</u> 720/59.94P <sup>*4</sup> 525/59.94I	<u>1080/59.94P(2x)/3G-A</u> <u>1080/59.94P(2x)/3G-B</u> 720/59.94P(2x) <sup>*4</sup> 720/59.94P(2x)/3G-B <sup>*4</sup> (The 4 formats above for SDI-I/O1, SDI-I/O2 only) <u>1080/59.94I</u> <u>1080/59.94P/3G-A</u> <u>1080/59.94P/3G-B</u> 720/59.94P <sup>*4</sup> 525/59.94I	–
		<b>Note</b> HFR output (1080/59.94) is linked to SDI-OUT1, SDI-OUT2, SDI-I/O1, and SDI-I/O2.	<b>Note</b> HFR output (1080/59.94) is linked to SDI-OUT1, SDI-OUT2, SDI-I/O1, and SDI-I/O2.	

CAMERA FORMAT	SYSTEM CONFIG → <OUTPUT FORMAT3> or SYSTEM CONFIG → <OUTPUT FORMAT4>	SYSTEM CONFIG → <OUTPUT FORMAT1>	SYSTEM CONFIG → <OUTPUT FORMAT2>	SYSTEM CONFIG → <OUTPUT FORMAT IP>
	<OUTPUT FORMAT3>: UHD-SDI A, UHD-SDI B, UHD-SDI C, UHD-SDI D <OUTPUT FORMAT4>: UHD-SDI E <sup>*1</sup> , UHD-SDI F <sup>*1</sup> , UHD-SDI G <sup>*1</sup> , UHD-SDI H <sup>*1</sup>	SDI-OUT1, SDI-OUT2, SDI-OUT3, SDI-OUT4	SDI-I/O1, SDI-I/O2, SDI-I/O3, SDI-I/O4	IP-OUT1 <sup>*2</sup> , IP-OUT2 <sup>*2</sup> , IP-OUT3 <sup>*2</sup> , IP-OUT4 <sup>*2</sup>
<u>1080/59.94P(3x)</u> (HDR/SDR)	<u>1080/59.94P(3x)/3G-A</u> <u>1080/59.94P(3x)/3G-B</u> <u>1080/59.94P(3x)/12G</u> <u>1080/59.94I(3x)</u> <u>1080/59.94I(3x)/12G</u> 720/59.94P(3x) <sup>*4</sup> 720/59.94P(3x)/12G	<u>1080/59.94P(3x)/3G-A</u> <u>1080/59.94P(3x)/3G-B</u> 720/59.94P(3x) <sup>*4</sup> (The 3 formats above for SDI-OUT1, SDI-OUT2 only) <u>1080/59.94I</u> <u>1080/59.94P/3G-A</u> <u>1080/59.94P/3G-B</u> 720/59.94P <sup>*4</sup> 525/59.94I	<u>1080/59.94P(3x)/3G-A</u> <u>1080/59.94P(3x)/3G-B</u> 720/59.94P(3x) <sup>*4</sup> (The 3 formats above for SDI-I/O1, SDI-I/O2 only) <u>1080/59.94I</u> <u>1080/59.94P/3G-A</u> <u>1080/59.94P/3G-B</u> 720/59.94P <sup>*4</sup> 525/59.94I	—
		<b>Note</b> HFR output (1080/59.94) is linked to SDI-OUT1, SDI-OUT2, SDI-I/O1, and SDI-I/O2.	<b>Note</b> HFR output (1080/59.94) is linked to SDI-OUT1, SDI-OUT2, SDI-I/O1, and SDI-I/O2.	
<u>1080/59.94P(4x)</u> (HDR/SDR)	<u>1080/59.94P(4x)/3G-A</u> <u>1080/59.94P(4x)/3G-B</u> <u>1080/59.94P(4x)/12G</u> <u>1080/59.94I(4x)</u> <u>1080/59.94I(4x)/3G-B</u> <u>1080/59.94I(4x)/12G</u> 720/59.94P(4x) <sup>*4</sup> 720/59.94P(4x)/3G-B <sup>*4</sup> 720/59.94P(4x)/12G	<u>1080/59.94P(4x)/3G-A</u> <u>1080/59.94P(4x)/3G-B</u> 720/59.94P(4x) <sup>*4</sup> 720/59.94P(4x)/3G-B <sup>*4</sup> (The 4 formats above for SDI-OUT1, SDI-OUT2 only) <u>1080/59.94I</u> <u>1080/59.94P/3G-A</u> <u>1080/59.94P/3G-B</u> 720/59.94P <sup>*4</sup> 525/59.94I	<u>1080/59.94P(4x)/3G-A</u> <u>1080/59.94P(4x)/3G-B</u> 720/59.94P(4x) <sup>*4</sup> 720/59.94P(4x)/3G-B <sup>*4</sup> (The 4 formats above for SDI-I/O1, SDI-I/O2 only) <u>1080/59.94I</u> <u>1080/59.94P/3G-A</u> <u>1080/59.94P/3G-B</u> 720/59.94P <sup>*4</sup> 525/59.94I	—
		<b>Note</b> HFR output (1080/59.94) is linked to SDI-OUT1, SDI-OUT2, SDI-I/O1, and SDI-I/O2.	<b>Note</b> HFR output (1080/59.94) is linked to SDI-OUT1, SDI-OUT2, SDI-I/O1, and SDI-I/O2.	
<u>1080/59.94P(6x)</u> (HDR/SDR)	<u>1080/59.94P(6x)/3G-A</u> <u>1080/59.94P(6x)/3G-B</u> <u>1080/59.94P(6x)/12G</u> <u>1080/59.94I(6x)</u> <u>1080/59.94I(6x)/3G-B</u> <u>1080/59.94I(6x)/12G</u> 720/59.94P(6x) <sup>*4</sup> 720/59.94P(6x)/3G-B <sup>*4</sup> 720/59.94P(6x)/12G	<u>1080/59.94P(6x)/3G-A</u> <u>1080/59.94P(6x)/3G-B</u> 720/59.94P(6x) <sup>*4</sup> 720/59.94P(6x)/3G-B <sup>*4</sup> (The 4 formats above for SDI-OUT1, SDI-OUT2 only) <u>1080/59.94I</u> <u>1080/59.94P/3G-A</u> <u>1080/59.94P/3G-B</u> 720/59.94P <sup>*4</sup> 525/59.94I	<u>1080/59.94P(6x)/3G-A</u> <u>1080/59.94P(6x)/3G-B</u> 720/59.94P(6x) <sup>*4</sup> 720/59.94P(6x)/3G-B <sup>*4</sup> (The 4 formats above for SDI-I/O1, SDI-I/O2 only) <u>1080/59.94I</u> <u>1080/59.94P/3G-A</u> <u>1080/59.94P/3G-B</u> 720/59.94P <sup>*4</sup> 525/59.94I	—
		<b>Note</b> HFR output (1080/59.94) is linked to SDI-OUT1, SDI-OUT2, SDI-I/O1, and SDI-I/O2.	<b>Note</b> HFR output (1080/59.94) is linked to SDI-OUT1, SDI-OUT2, SDI-I/O1, and SDI-I/O2.	

CAMERA FORMAT	SYSTEM CONFIG → <OUTPUT FORMAT3> or SYSTEM CONFIG → <OUTPUT FORMAT4>	SYSTEM CONFIG → <OUTPUT FORMAT1>	SYSTEM CONFIG → <OUTPUT FORMAT2>	SYSTEM CONFIG → <OUTPUT FORMAT IP>
	<OUTPUT FORMAT3>: UHD-SDI A, UHD-SDI B, UHD-SDI C, UHD-SDI D <OUTPUT FORMAT4>: UHD-SDI E <sup>*1</sup> , UHD-SDI F <sup>*1</sup> , UHD-SDI G <sup>*1</sup> , UHD-SDI H <sup>*1</sup>	SDI-OUT1, SDI-OUT2, SDI-OUT3, SDI-OUT4	SDI-I/O1, SDI-I/O2, SDI-I/O3, SDI-I/O4	IP-OUT1 <sup>*2</sup> , IP-OUT2 <sup>*2</sup> , IP-OUT3 <sup>*2</sup> , IP-OUT4 <sup>*2</sup>
<u>1080/59.94P(8x)</u> (HDR/SDR)	<u>1080/59.94P(8x)/3G-A</u> <u>1080/59.94P(8x)/3G-B</u> <u>1080/59.94P(8x)/12G</u> <u>1080/59.94I(8x)</u> <u>1080/59.94I(8x)/3G-B</u> <u>1080/59.94I(8x)/12G</u> 720/59.94P(8x) <sup>*4</sup> 720/59.94P(8x)/3G-B <sup>*4</sup> 720/59.94P(8x)/12G	<u>1080/59.94P(8x)/3G-A</u> <u>1080/59.94P(8x)/3G-B</u> 720/59.94P(8x) <sup>*4</sup> 720/59.94P(8x)/3G-B <sup>*4</sup> (The 4 formats above for SDI-OUT1, SDI-OUT2 only) <u>1080/59.94I</u> <u>1080/59.94P/3G-A</u> <u>1080/59.94P/3G-B</u> 720/59.94P <sup>*4</sup> 525/59.94I	<u>1080/59.94P(8x)/3G-A</u> <u>1080/59.94P(8x)/3G-B</u> 720/59.94P(8x) <sup>*4</sup> 720/59.94P(8x)/3G-B <sup>*4</sup> (The 4 formats above for SDI-I/O1, SDI-I/O2 only) <u>1080/59.94I</u> <u>1080/59.94P/3G-A</u> <u>1080/59.94P/3G-B</u> 720/59.94P <sup>*4</sup> 525/59.94I	–
	<b>Note</b> HFR output (1080/59.94) is linked to SDI-OUT1, SDI-OUT2, SDI-I/O1, and SDI-I/O2.		<b>Note</b> HFR output (1080/59.94) is linked to SDI-OUT1, SDI-OUT2, SDI-I/O1, and SDI-I/O2.	

\*1 Configurable only on HDCU5000 when HKCU-SDI50 is installed.

\*2 Configurable only when the HKCU-SFP50 is installed.

\*3 720 output can be selected when CCU VIDEO CONVERT is set to ENABLE.

\*4 720 output can be selected when both CCU VIDEO CONVERT is set to ENABLE and the HDR mode of the connected camera is set to OFF.

**Formats settable for UHD SDI, SDI OUT, SDI I/O, and IP OUT connectors (when FIBER TRANSMIT RATE is set to ULTRA and SYSTEM is set to 1.000(625))**

**Note**

For underlined formats, the mode can be switched between HDR and SDR according to the Live HDR mode setting of the connected camera.

CAMERA FORMAT	SYSTEM CONFIG → <OUTPUT FORMAT3> or SYSTEM CONFIG → <OUTPUT FORMAT4>	SYSTEM CONFIG → <OUTPUT FORMAT1>	SYSTEM CONFIG → <OUTPUT FORMAT2>	SYSTEM CONFIG → <OUTPUT FORMAT IP>
	<OUTPUT FORMAT3>: UHD-SDI A, UHD-SDI B, UHD-SDI C, UHD-SDI D <OUTPUT FORMAT4>: UHD-SDI E <sup>*1</sup> , UHD-SDI F <sup>*1</sup> , UHD-SDI G <sup>*1</sup> , UHD-SDI H <sup>*1</sup>	SDI-OUT1, SDI-OUT2, SDI-OUT3, SDI-OUT4	SDI-I/O1, SDI-I/O2, SDI-I/O3, SDI-I/O4	IP-OUT1 <sup>*2</sup> , IP-OUT2 <sup>*2</sup> , IP-OUT3 <sup>*2</sup> , IP-OUT4 <sup>*2</sup>
<u>3840x2160/50P(2x)</u> (HDR/SDR)	<u>3840x2160/50P/12G</u>	<u>3840x2160/50P/SQD/3G-A</u>	<u>3840x2160/50P/SQD/3G-A</u>	<u>3840x2160/50P/12G</u> (IP-OUT4 only)
<u>3840x2160/50P</u> (HDR/SDR)	<u>3840x2160/50P/SQD/3G-A</u>	<u>3840x2160/50P/SQD/3G-B</u>	<u>3840x2160/50P/SQD/3G-B</u>	<u>1080/50I</u> (IP-OUT1, IP-OUT2, IP-OUT3 only)
	<u>3840x2160/50P/2SI/3G-A</u>	<u>3840x2160/50P/2SI/3G-A</u>	<u>3840x2160/50P/2SI/3G-A</u>	<u>1080/50P/3G-A</u> (IP-OUT1, IP-OUT2 only)
	<u>3840x2160/50P/2SI/3G-B</u>	<u>3840x2160/50P/2SI/3G-B</u>	<u>3840x2160/50P/2SI/3G-B</u>	
		(The 4 formats above for SDI-OUT1, SDI-OUT2 only)	(The 4 formats above for SDI-I/O1, SDI-I/O2 only)	
		<u>1080/50I</u>	<u>1080/50I</u>	
		<u>1080/50P/3G-A</u>	<u>1080/50P/3G-A</u>	
		<u>1080/50P/3G-B</u>	<u>1080/50P/3G-B</u>	
		<u>720/50P<sup>*3</sup></u>	<u>720/50P<sup>*3</sup></u>	
		<u>625/50I</u>	<u>625/50I</u>	
	<b>Note</b> The UHD-SDI B, UHD-SDI C, UHD-SDI D, UHD-SDI E, UHD-SDI F, UHD-SDI G, and UHD-SDI H settings are linked to the UHD SDI A setting.	<b>Note</b> The 4K output settings are linked to the SDI-OUT1 settings.	<b>Note</b> The 4K output settings are linked to the SDI-I/O1 settings.	
<u>3840x2160/25P</u> (HDR/SDR)	<u>3840x2160/25P/6G</u>	<u>3840x2160/25PsF/SQD/3G-B</u>	<u>3840x2160/25PsF/SQD/3G-B</u>	–
	<u>3840x2160/25PsF/SQD/3G-B</u>	<u>3840x2160/25PsF/SQD/1.5G</u>	<u>3840x2160/25PsF/SQD/1.5G</u>	
	<u>3840x2160/25P/2SI/3G-B</u>	(The 2 formats above for SDI-OUT1, SDI-OUT2 only)	(The 2 formats above for SDI-I/O1, SDI-I/O2 only)	
	<u>3840x2160/25PsF/SQD/1.5G</u>	<u>1080/25PsF</u>	<u>1080/25PsF</u>	
		<u>625/25PsF</u>	<u>625/25PsF</u>	
		<b>Note</b> The 4K output settings are linked to the SDI-OUT1 settings.	<b>Note</b> The 4K output settings are linked to the SDI-OUT1 settings.	
<u>3840x2160/24P</u> (HDR/SDR)	<u>3840x2160/24P/6G</u>	<u>3840x2160/24PsF/SQD/3G-B</u>	<u>3840x2160/24PsF/SQD/3G-B</u>	–
	<u>3840x2160/24PsF/SQD/3G-B</u>	<u>3840x2160/24PsF/SQD/1.5G</u>	<u>3840x2160/24PsF/SQD/1.5G</u>	
	<u>3840x2160/24P/2SI/3G-B</u>	(The 2 formats above for SDI-OUT1, SDI-OUT2 only)	(The 2 formats above for SDI-I/O1, SDI-I/O2 only)	
	<u>3840x2160/24PsF/SQD/1.5G</u>	<u>1080/50I</u>	<u>1080/50I</u>	
		<u>1080/24PsF</u>	<u>1080/24PsF</u>	
		<u>625/50I</u>	<u>625/50I</u>	
		<b>Note</b> The 4K output settings are linked to the SDI-OUT1 settings.	<b>Note</b> The 4K output settings are linked to the SDI-OUT1 settings.	

CAMERA FORMAT	SYSTEM CONFIG → <OUTPUT FORMAT3> or SYSTEM CONFIG → <OUTPUT FORMAT4>	SYSTEM CONFIG → <OUTPUT FORMAT1>	SYSTEM CONFIG → <OUTPUT FORMAT2>	SYSTEM CONFIG → <OUTPUT FORMAT IP>
	<OUTPUT FORMAT3>: UHD-SDI A, UHD-SDI B, UHD-SDI C, UHD-SDI D <OUTPUT FORMAT4>: UHD-SDI E <sup>*1</sup> , UHD-SDI F <sup>*1</sup> , UHD-SDI G <sup>*1</sup> , UHD-SDI H <sup>*1</sup>	SDI-OUT1, SDI-OUT2, SDI-OUT3, SDI-OUT4	SDI-I/O1, SDI-I/O2, SDI-I/O3, SDI-I/O4	IP-OUT1 <sup>*2</sup> , IP-OUT2 <sup>*2</sup> , IP-OUT3 <sup>*2</sup> , IP-OUT4 <sup>*2</sup>
<u>1080/50P</u> (HDR/SDR)	<u>1080/50I</u> <u>1080/50P/3G-A</u> <u>1080/50P/3G-B</u>	<u>1080/50I</u> <u>1080/50P/3G-A</u> <u>1080/50P/3G-B</u> 720/50P <sup>*3</sup> 625/50I	<u>1080/50I</u> <u>1080/50P/3G-A</u> <u>1080/50P/3G-B</u> 720/50P <sup>*3</sup> 625/50I	<u>1080/50P/3G-A</u> (IP-OUT1, IP-OUT2 only) <u>1080/50I</u> (IP-OUT1, IP-OUT2, IP-OUT3 only)
<u>1080/25PsF</u> (HDR/SDR)	<u>1080/25PsF</u>	<u>1080/25PsF</u> 625/25PsF	<u>1080/25PsF</u> 625/25PsF	–
<u>1080/24PsF</u> (HDR/SDR)	<u>1080/24PsF</u>	<u>1080/50I</u> <u>1080/24PsF</u> 625/50I	<u>1080/50I</u> <u>1080/24PsF</u> 625/50I	–
1080/50I(RGB444) (SDR)	1080/50I 1080/50I(RGB444)/3G-B	1080/50I 1080/50I(RGB444)/3G-B 625/50I	1080/50I 1080/50I(RGB444)/3G-B 625/50I	1080/50I (IP-OUT1, IP-OUT2, IP-OUT3 only)
1080/ 25PsF(RGB444) (SDR)	1080/25PsF 1080/25PsF(RGB444)/3G-B	1080/25PsF 1080/25PsF(RGB444)/3G-B 625/25PsF	1080/25PsF 1080/25PsF(RGB444)/3G-B 625/25PsF	–
1080/ 24PsF(RGB444) (SDR)	1080/24PsF 1080/24PsF(RGB444)/3G-B	1080/50I 1080/24PsF 1080/24PsF(RGB444)/3G-B 625/50I	1080/50I 1080/24PsF 1080/24PsF(RGB444)/3G-B 625/50I	–
<u>1080/50P(2x)</u> (HDR/SDR)	<u>1080/50P(2x)/3G-A</u> <u>1080/50P(2x)/3G-B</u> <u>1080/50P(2x)/12G</u> <u>1080/50I(2x)</u> <u>1080/50I(2x)/3G-B</u> <u>1080/50I(2x)/12G</u> 720/50P(2x) <sup>*4</sup> 720/50P(2x)/3G-B <sup>*4</sup> 720/50P(2x)/12G	<u>1080/50P(2x)/3G-A</u> <u>1080/50P(2x)/3G-B</u> 720/50P(2x) <sup>*4</sup> 720/50P(2x)/3G-B <sup>*4</sup> (The 4 formats above for SDI-OUT1, SDI-OUT2 only) <u>1080/50I</u> <u>1080/50P/3G-A</u> <u>1080/50P/3G-B</u> 720/50P <sup>*4</sup> 625/50I	<u>1080/50P(2x)/3G-A</u> <u>1080/50P(2x)/3G-B</u> 720/50P(2x) <sup>*4</sup> 720/50P(2x)/3G-B <sup>*4</sup> (The 4 formats above for SDI-I/O1, SDI-I/O2 only) <u>1080/50I</u> <u>1080/50P/3G-A</u> <u>1080/50P/3G-B</u> 720/50P <sup>*4</sup> 625/50I	–
		<b>Note</b> HFR output (1080/50) is linked to SDI-OUT1, SDI-OUT2, SDI-I/O1, and SDI-I/O2.	<b>Note</b> HFR output (1080/50) is linked to SDI-OUT1, SDI-OUT2, SDI-I/O1, and SDI-I/O2.	

CAMERA FORMAT	SYSTEM CONFIG → <OUTPUT FORMAT3> or SYSTEM CONFIG → <OUTPUT FORMAT4>	SYSTEM CONFIG → <OUTPUT FORMAT1>	SYSTEM CONFIG → <OUTPUT FORMAT2>	SYSTEM CONFIG → <OUTPUT FORMAT IP>
	<OUTPUT FORMAT3>: UHD-SDI A, UHD-SDI B, UHD-SDI C, UHD-SDI D <OUTPUT FORMAT4>: UHD-SDI E <sup>*1</sup> , UHD-SDI F <sup>*1</sup> , UHD-SDI G <sup>*1</sup> , UHD-SDI H <sup>*1</sup>	SDI-OUT1, SDI-OUT2, SDI-OUT3, SDI-OUT4	SDI-I/O1, SDI-I/O2, SDI-I/O3, SDI-I/O4	IP-OUT1 <sup>*2</sup> , IP-OUT2 <sup>*2</sup> , IP-OUT3 <sup>*2</sup> , IP-OUT4 <sup>*2</sup>
<u>1080/50P(3x)</u> (HDR/SDR)	<u>1080/50P(3x)/3G-A</u> <u>1080/50P(3x)/3G-B</u> <u>1080/50P(3x)/12G</u> <u>1080/50I(3x)</u> <u>1080/50I(3x)/12G</u> 720/50P(3x) <sup>*4</sup> 720/50P(3x)/12G	<u>1080/50P(3x)/3G-A</u> <u>1080/50P(3x)/3G-B</u> 720/50P(3x) <sup>*4</sup> (The 3 formats above for SDI-OUT1, SDI-OUT2 only) <u>1080/50I</u> <u>1080/50P/3G-A</u> <u>1080/50P/3G-B</u> 720/50P <sup>*4</sup> 625/50I	<u>1080/50P(3x)/3G-A</u> <u>1080/50P(3x)/3G-B</u> 720/50P(3x) <sup>*4</sup> (The 3 formats above for SDI-I/O1, SDI-I/O2 only) <u>1080/50I</u> <u>1080/50P/3G-A</u> <u>1080/50P/3G-B</u> 720/50P <sup>*4</sup> 625/50I	—
		<b>Note</b> HFR output (1080/50) is linked to SDI-OUT1, SDI-OUT2, SDI-I/O1, and SDI-I/O2.	<b>Note</b> HFR output (1080/50) is linked to SDI-OUT1, SDI-OUT2, SDI-I/O1, and SDI-I/O2.	
<u>1080/50P(4x)</u> (HDR/SDR)	<u>1080/50P(4x)/3G-A</u> <u>1080/50P(4x)/3G-B</u> <u>1080/50P(4x)/12G</u> <u>1080/50I(4x)</u> <u>1080/50I(4x)/3G-B</u> <u>1080/50I(4x)/12G</u> 720/50P(4x) <sup>*4</sup> 720/50P(4x)/3G-B <sup>*4</sup> 720/50P(4x)/12G	<u>1080/50P(4x)/3G-A</u> <u>1080/50P(4x)/3G-B</u> 720/50P(4x) <sup>*4</sup> 720/50P(4x)/3G-B <sup>*4</sup> (The 4 formats above for SDI-OUT1, SDI-OUT2 only) <u>1080/50I</u> <u>1080/50P/3G-A</u> <u>1080/50P/3G-B</u> 720/50P <sup>*4</sup> 625/50I	<u>1080/50P(4x)/3G-A</u> <u>1080/50P(4x)/3G-B</u> 720/50P(4x) <sup>*4</sup> 720/50P(4x)/3G-B <sup>*4</sup> (The 4 formats above for SDI-I/O1, SDI-I/O2 only) <u>1080/50I</u> <u>1080/50P/3G-A</u> <u>1080/50P/3G-B</u> 720/50P <sup>*4</sup> 625/50I	—
		<b>Note</b> HFR output (1080/50) is linked to SDI-OUT1, SDI-OUT2, SDI-I/O1, and SDI-I/O2.	<b>Note</b> HFR output (1080/50) is linked to SDI-OUT1, SDI-OUT2, SDI-I/O1, and SDI-I/O2.	
<u>1080/50P(6x)</u> (HDR/SDR)	<u>1080/50P(6x)/3G-A</u> <u>1080/50P(6x)/3G-B</u> <u>1080/50P(6x)/12G</u> <u>1080/50I(6x)</u> <u>1080/50I(6x)/3G-B</u> <u>1080/50I(6x)/12G</u> 720/50P(6x) <sup>*4</sup> 720/50P(6x)/3G-B <sup>*4</sup> 720/50P(6x)/12G	<u>1080/50P(6x)/3G-A</u> <u>1080/50P(6x)/3G-B</u> 720/50P(6x) <sup>*4</sup> 720/50P(6x)/3G-B <sup>*4</sup> (The 4 formats above for SDI-OUT1, SDI-OUT2 only) <u>1080/50I</u> <u>1080/50P/3G-A</u> <u>1080/50P/3G-B</u> 720/50P <sup>*4</sup> 625/50I	<u>1080/50P(6x)/3G-A</u> <u>1080/50P(6x)/3G-B</u> 720/50P(6x) <sup>*4</sup> 720/50P(6x)/3G-B <sup>*4</sup> (The 4 formats above for SDI-I/O1, SDI-I/O2 only) <u>1080/50I</u> <u>1080/50P/3G-A</u> <u>1080/50P/3G-B</u> 720/50P <sup>*4</sup> 625/50I	—
		<b>Note</b> HFR output (1080/50) is linked to SDI-OUT1, SDI-OUT2, SDI-I/O1, and SDI-I/O2.	<b>Note</b> HFR output (1080/50) is linked to SDI-OUT1, SDI-OUT2, SDI-I/O1, and SDI-I/O2.	



CAMERA FORMAT	SYSTEM CONFIG → <OUTPUT FORMAT3> or SYSTEM CONFIG → <OUTPUT FORMAT4>	SYSTEM CONFIG → <OUTPUT FORMAT1>	SYSTEM CONFIG → <OUTPUT FORMAT2>	SYSTEM CONFIG → <OUTPUT FORMAT IP>
	<OUTPUT FORMAT3>: UHD-SDI A, UHD-SDI B, UHD-SDI C, UHD-SDI D <OUTPUT FORMAT4>: UHD-SDI E <sup>*1</sup> , UHD-SDI F <sup>*1</sup> , UHD-SDI G <sup>*1</sup> , UHD-SDI H <sup>*1</sup>	SDI-OUT1, SDI-OUT2, SDI-OUT3, SDI-OUT4	SDI-I/O1, SDI-I/O2, SDI-I/O3, SDI-I/O4	IP-OUT1 <sup>*2</sup> , IP-OUT2 <sup>*2</sup> , IP-OUT3 <sup>*2</sup> , IP-OUT4 <sup>*2</sup>

<u>1080/50P(8x)</u> (HDR/SDR)	<u>1080/50P(8x)/3G-A</u>	<u>1080/50P(8x)/3G-A</u>	<u>1080/50P(8x)/3G-A</u>	-
	<u>1080/50P(8x)/3G-B</u>	<u>1080/50P(8x)/3G-B</u>	<u>1080/50P(8x)/3G-B</u>	
	<u>1080/50P(8x)/12G</u>	720/50P(8x) <sup>*4</sup>	720/50P(8x) <sup>*4</sup>	
	<u>1080/50I(8x)</u>	720/50P(8x)/3G-B <sup>*4</sup>	720/50P(8x)/3G-B <sup>*4</sup>	
	<u>1080/50I(8x)/3G-B</u>	(The 4 formats above for SDI-OUT1, SDI-OUT2 only)	(The 4 formats above for SDI-I/O1, SDI-I/O2 only)	
	<u>1080/50I(8x)/12G</u>	<u>1080/50I</u>	<u>1080/50I</u>	
	720/50P(8x) <sup>*4</sup>	<u>1080/50P/3G-A</u>	<u>1080/50P/3G-A</u>	
	720/50P(8x)/3G-B <sup>*4</sup>	<u>1080/50P/3G-B</u>	<u>1080/50P/3G-B</u>	
	720/50P(8x)/12G	720/50P <sup>*4</sup>	720/50P <sup>*4</sup>	
		625/50I	625/50I	

**Note**

HFR output (1080/50) is linked to SDI-OUT1, SDI-OUT2, SDI-I/O1, and SDI-I/O2.

**Note**

HFR output (1080/50) is linked to SDI-OUT1, SDI-OUT2, SDI-I/O1, and SDI-I/O2.

\*1 Configurable only on HDCU5000 when HKCU-SDI50 is installed.

\*2 Configurable only when the HKCU-SFP50 is installed.

\*3 720 output can be selected when CCU VIDEO CONVERT is set to ENABLE.

\*4 720 output can be selected when both CCU VIDEO CONVERT is set to ENABLE and the HDR mode of the connected camera is set to OFF.

**Relationship between output interface and BNC connector assignment**

HFR	UHD SDI				SDI OUT		SDI I/O	
	A/E <sup>*1</sup>	B/F <sup>*1</sup>	C/G <sup>*1</sup>	D/H <sup>*1</sup>	1	2	1	2
4K 2x	12G	2160P	(Link-1 Link-2)	(Link-1 Link-2)	-	-	-	-
	3G-A/B (SQD/2SI)		(Link-1 Link-2 Link-3 Link-4)	(Link-5 Link-6 Link-7 Link-8)				
HD 2x	3G-A/B, 1.5G	1080P/720P	(Link-1/2 Link-1/2)	(Link-1/2 Link-1/2)	(Link-1/2 Link-1/2)	(Link-1/2 Link-1/2)	(Link-1/2 Link-1/2)	(Link-1/2 Link-1/2)
	3G-B	1080i/720P	(Link-1/2 Link-1/2)	(Link-1/2 Link-1/2)	(Link-1/2 Link-1/2)	(Link-1/2 Link-1/2)	(Link-1/2 Link-1/2)	(Link-1/2 Link-1/2)
3x	3G-A/B, 1.5G	1080i/720P	(Link-1 Link-2 Link-3 Link-2)	(Link-1 Link-2 Link-3 Link-2)	(Link-1 Link-2 Link-3 Link-2)	(Link-1 Link-2 Link-3 Link-2)	(Link-1 Link-2 Link-3 Link-2)	(Link-1 Link-2 Link-3 Link-2)
4x	3G-A/B, 1.5G	1080P/720P	(Link-1 Link-2 Link-3 Link-4)	(Link-1 Link-2 Link-3 Link-4)	(Link-1 Link-2 Link-3 Link-4)	(Link-1 Link-2 Link-3 Link-4)	(Link-1 Link-2 Link-3 Link-4)	(Link-1 Link-2 Link-3 Link-4)
	3G-B	1080i/720P	(Link-1/2 Link-3/4 Link-1/2 Link-3/4)	(Link-1/2 Link-3/4 Link-1/2 Link-3/4)	(Link-1/2 Link-3/4 Link-1/2 Link-3/4)	(Link-1/2 Link-3/4 Link-1/2 Link-3/4)	(Link-1/2 Link-3/4 Link-1/2 Link-3/4)	(Link-1/2 Link-3/4 Link-1/2 Link-3/4)
6x	12G	1080P	(Link-1 Link-2)	(Link-1 Link-2)	-	-	-	-
	3G-A/B, 1.5G	1080P/720P	(Link-1 Link-2 Link-3 Link-4)	(Link-4 Link-5 Link-6 Link-3)	(Link-4 Link-5 Link-6 Link-3)	(Link-4 Link-5 Link-6 Link-3)	(Link-4 Link-5 Link-6 Link-3)	(Link-4 Link-5 Link-6 Link-3)
8x	3G-B	1080i/720P	(Link-1/2 Link-3/4 Link-5/6 Link-3/4)	(Link-1/2 Link-3/4 Link-5/6 Link-3/4)	(Link-1/2 Link-3/4 Link-5/6 Link-3/4)	(Link-1/2 Link-3/4 Link-5/6 Link-3/4)	(Link-1/2 Link-3/4 Link-5/6 Link-3/4)	(Link-1/2 Link-3/4 Link-5/6 Link-3/4)
	12G	1080P	(Link-1 Link-2)	(Link-1 Link-2)	-	-	-	-
3x	3G-A/B, 1.5G	1080P/720P	(Link-1 Link-2 Link-3 Link-4)	(Link-5 Link-6 Link-7 Link-8)	(Link-5 Link-6 Link-7 Link-8)	(Link-5 Link-6 Link-7 Link-8)	(Link-5 Link-6 Link-7 Link-8)	(Link-5 Link-6 Link-7 Link-8)
	3G-B	1080i/720P	(Link-1/2 Link-3/4 Link-5/6 Link-7/8)	(Link-1/2 Link-3/4 Link-5/6 Link-7/8)	(Link-1/2 Link-3/4 Link-5/6 Link-7/8)	(Link-1/2 Link-3/4 Link-5/6 Link-7/8)	(Link-1/2 Link-3/4 Link-5/6 Link-7/8)	(Link-1/2 Link-3/4 Link-5/6 Link-7/8)

\*1 Configurable only on HDCU5000 when HKCU-SDI50 is installed.

# VIDEO/MONITOR Menu

VIDEO/MONITOR			
Page name Page No.	Item	Set value	Description
<COLOR BAR> V01	4K/HD-BAR SELECT	<b>BAR 16:9(100%)</b> , BAR 16:9(75%), SMPTE 16:9(BLACK), SMPTE 16:9(-I/Q), BAR 4:3(100%), BAR 4:3(75%), SMPTE 4:3(BLACK), SMPTE 4:3(-I/Q), MF-ARIB(75%), MF-ARIB(100%), MF-ARIB(+I), MF-SMPTE(-I,Q), MF-SMPTE(75%,Q), MF-SMPTE(100%,Q), MF-SMPTE(+I,Q), HD-CUSTOM, SDI CHECK FIELD, Y-RAMP, Y/C-RAMP, HD-CUSTOM2	Selects the color bars for 4K output/HD output.
	MF-CB	<b>MODIFY</b> , EVEN	Sets the stripe width for multi-format color bar output. <b>MODIFY</b> : Stripe width adjusted to prevent colors mixing in 4:3 Edge crop mode. <b>EVEN</b> : Stripe width in accordance with standard.
	SLOPE	<b>WIDE</b> , NARROW	Sets the color difference signal band of the color bars. <b>WIDE</b> : Band not limited. <b>NARROW</b> : Band is limited to prevent ringing.
SD			
	SOURCE	4K/HD BAR, <b>SD BAR</b>	Selects the color bar signal source for output to SD. <b>4K/HD BAR</b> : Down converts the 4K/HD color bars and then outputs it. <b>SD BAR</b> : Outputs the SD color bars selected in SELECT.
	SELECT	When SYSTEM CONFIG menu → <MULTI FORMAT> page → SYSTEM is set to 1.001(525): <b>SMPTE</b> , EIA, FULL, 95%, NTSC100%, Y/C-RAMP, Y-RAMP When SYSTEM CONFIG menu → <MULTI FORMAT> page → SYSTEM is set to 1.000(625): <b>SMPTE</b> , EIA, FULL, 95%, PAL100%, Y/C-RAMP, Y-RAMP	Selects the SD color bars.
	BAR-CHARACTER	ON, <b>OFF</b>	Sets the character superimposition on the color bar signal.
	MOVING SYMBOL	ON, <b>OFF</b>	Sets symbol moving on the color bar screen.
	TYPE	0, 1, 2	Selects the symbol type.
	SIZE	<b>SMALL</b> , LARGE	Selects the symbol size.
	2SI DIAMOND MARK	ON, <b>OFF</b>	Sets the marker display for 4K 2SI output. This function is for displaying a test pattern like the following in the area at the bottom right of the 4K color bar during 4K 2-sample interleave output. OK is displayed if the connections for Links 1 to 4 are correct, and OK is not displayed if they are incorrect. This function can be used to check the connections.

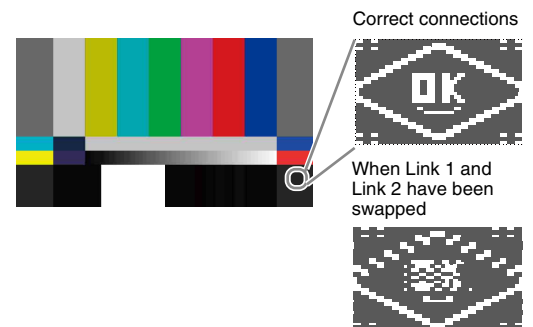

VIDEO/MONITOR				
Page name Page No.	Item	Set value	Description	
<COLOR BAR> V01	HFR CHANNEL MARK	ON, <b>OFF</b>		
<BAR CHARACTER> V02	BAR CHARACTER		Sets the character string to be displayed on each of lines 1 to 16.	
	ALL CLEAR		Clears all the character strings set for BAR CHARACTER.	
<CCU VIDEO> V03	MONO COLOR	ON, OFF	Turns the MONO COLOR function ON/OFF.	
	PHASE	0 to 359, <b>0</b>	Sets the MONO COLOR function hue adjustment.	
	SATURATION	-99 to 99, <b>0</b>	Sets the MONO COLOR function color level adjustment.	
<DOWNCONVERT> V04	4K-HD DOWNCONVERT FILTER	<b>1</b> , 2, 3, 4, 1(V:0.3), 1(V:0.6)	Selects the type of filter for downconverting from 4K video signals to HD signals. Enabled when CAMERA FORMAT is set to UHD/59.94P(4K/HDR) or UHD/50P(4K/HDR).	
	SD ASPECT	SQUEEZE, <b>EDGE CROP</b> , LETTER BOX	Selects the aspect ratio for SD output.	
	NTSC SETUP	<b>7.5</b> , 0 IRE	Sets the NTSC signal setup level.	
<MONITOR> V05	CHARACTER LEVEL	1, 2, 3, 4, <b>5</b>	Sets the brightness of text in menus, etc.	
	LEVEL GATE	<b>OFF</b> , 1&2, 1, 2, (---)	Sets level gate display. <b>OFF</b> : Level gate is not displayed. <b>1</b> : Displays level gate 1. <b>2</b> : Displays level gate 2. <b>1&amp;2</b> : Displays level gate 1 & 2. <b>(---)</b> : Displayed when a camera is not connected (Display only).	
	Y-LEVEL1	MIN	0 to 108% <b>49</b>	Sets the minimum detection level for level gate 1 display.
		MAX	0 to 108% <b>61</b>	Sets the maximum detection levels for level gate 1 display.
		LEVEL	-99 to 99 <b>-25</b>	Sets the zebra display level to be added to the detection area.
	Y-LEVEL2	MIN	0 to 108% <b>74</b>	Sets the minimum detection level for level gate 2 display.
		MAX	0 to 108% <b>108</b>	Sets the maximum detection levels for level gate 2 display.
		LEVEL	-99 to 99 <b>-25</b>	Sets the zebra display level to be added to the detection area.
	GATE MARKER	<b>OFF</b> , ON, (---)	Sets the display of the gate signal detected by the camera. <b>OFF</b> : Gate signal is not displayed. <b>ON</b> : Displays zebra in the area (skin gate, etc.) detected by the camera. <b>(---)</b> : Displayed when a camera is not connected (Display only).	
	LEVEL	-99 to 99 <b>0</b>	Sets the zebra display level to be added to the detection area.	
	ASPECT MARKER	<b>OFF</b> , ON	Sets aspect marker display.	
	SELECT	<b>4:3</b> , 13:9, 14:9, EU VISTA, VISTA, CINEMA, FOLLOW DC	Selects the marker type.	
	MODULATION ON/OFF	<b>OFF</b> , ON	Sets the mask function for outside the marker frame.	
	MODULATION LEVEL	-99 to 99 <b>0</b>	Sets the mask level.	

VIDEO/MONITOR			
Page name Page No.	Item	Set value	Description
<SPIRIT LEVEL> V06	INDICATOR	<b>OFF</b> , ON, ---	Sets spirit level display. This can be set when connected with a camera which has a lens that supports serial communication attached.
	REVERSE	<b>OFF</b> , ON	Selects the indicator move direction for tilting.
	H POSITION	0 to 99 <b>50</b>	Spirit level display position (horizontal)
	V POSITION	0 to 99 <b>50</b>	Spirit level display position (vertical)
	MESSAGE	<b>ALL</b> , WARNING, OFF	Sets the display of messages for the camera auto setup operation status, warnings that occur in the system, etc. <b>ALL</b> : Displays all messages. <b>WARNING</b> : Displays system warning messages and menu control messages. <b>OFF</b> : Displays only menu control messages.
<DISPLAY> V07 Sets the items to be displayed on the camera setting status page of the status display screen.	CAMERA	<b>ON</b> , OFF	Displays or hides the model name of the connected camera.
	LENS FILE	<b>ON</b> , OFF	Displays or hides the LENS FILE name.
	MASTER GAIN	<b>ON</b> , OFF	Displays or hides the master gain setting value.
	MODE	<b>STEP GAIN</b> , MASTER WHITE, F DROP GAIN, TOTAL GAIN	Switches the MASTER GAIN display mode. <b>STEP GAIN</b> : Displays the STEP GAIN value. <b>MASTER WHITE</b> : Displays the MASTER WHITE GAIN value. <b>F DROP GAIN</b> : Displays the F DROP GAIN value. <b>TOTAL GAIN</b> : Displays the total value of the STEP GAIN, MASTER GAIN, and F DROP GAIN values combined.
	MASTER WHITE IND	<b>ON</b> , OFF	Displays or hides the enabled status of the master white gain.
	SHUTTER	<b>ON</b> , OFF	Displays or hides the shutter speed/ECS frequency setting value.
	ND FILTER	<b>ON</b> , OFF	Displays or hides the ND filter type.
	CC FILTER	<b>ON</b> , OFF	Displays or hides the CC filter type.
	IRIS	<b>ON</b> , OFF	Displays or hides the iris status.
	EXTENDER	<b>ON</b> , OFF	Displays or hides the lens extender/digital extender status.
	F DROP IND	<b>ON</b> , OFF	Display or hides the F-drop status.
	MIC	<b>ON</b> , OFF	Displays or hides the camera microphone switch status.

## AUDIO/INTERCOM Menu

AUDIO/INTERCOM				
Page name Page No.	Item	Set value	Description	
<MIC GAIN> A01	CAM MIC GAIN		Sets the camera microphone gain.	
	CH1	(--), 20, 30, 40, 50, <b>60</b> dB	Set according to the microphone used.	
	CH2	(--), 20, 30, 40, 50, <b>60</b> dB	(--): Displayed when a camera is not connected (Display only).	
<AUDIO OUT> A02	DELAY	0, 5, 11, 16, 21, 27, 32, 37, 43, 48, 53, 59, 64, 69, 75, 80 ms	Sets the camera microphone output phase.	
	AES/EBU OUT	<b>MIC1/2</b> , AES/EBU	Selects the AES/EBU output. <b>MIC1/2</b> : Outputs the camera MIC1/2 input from the AES/EBU connector of the CCU. <b>AES/EBU</b> : Outputs the camera AES/EBU input from the AES/EBU connector of the CCU.	
	ANALOG OUT	<b>MIC1/2</b> , AES/EBU	Selects the MIC OUT ANALOG output. <b>MIC1/2</b> : Outputs the camera MIC1/2 input from the AUDIO OUT connector of the CCU. <b>AES/EBU</b> : Outputs the camera AES/EBU input from the AUDIO OUT connector of the CCU.	
	CH1 : LEVEL	-20, <b>0</b> , +4 dBu	Sets the AUDIO CH1 output level.	
	CH1 : ADJUST	-99 to 99, <b>0</b>		
	CH2 : LEVEL	-20, <b>0</b> , +4 dBu	Sets the AUDIO CH2 output level.	
	CH2 : ADJUST	-99 to 99, <b>0</b>		
	<INTERCOM> A03	INTERCOM CH	1CH(PROD), <b>2CH(PROD&amp;ENG)</b>	Selects the intercom channel number to be used.
		PRODUCER INTERFACE	CLEAR COM, <b>4WIRE</b> , RTS	Sets the producer line intercom system.
		SIDE TONE CANCEL	-99 to 99 <b>0</b>	Sets the side tone cancel level. (Setting is possible when CLEAR COM or RTS is selected)
TERMINATION		<b>OFF</b> , ON	Sets termination resistance (200 ohms). (Setting is possible when CLEAR COM or RTS is selected) <b>OFF</b> : Displayed when 4WIRE is selected in PRODUCER INTERFACE (Display only).	
ENGINEER INTERFACE		CLEAR COM, <b>4WIRE</b> , RTS	Sets the engineer line intercom system.	
SIDE TONE CANCEL		0 to 99 <b>0</b>	Sets the side tone cancel level. (Setting is possible when CLEAR COM or RTS is selected)	
TERMINATION		<b>OFF</b> , ON	Sets termination resistance (200 ohms). (Setting is possible when CLEAR COM or RTS is selected) <b>OFF</b> : Displayed when 4WIRE is selected in ENGINEER INTERFACE (Display only).	
PGM1 INPUT LEVEL		-20, <b>0</b> , +4 dBu	Sets the PGM1 input level.	
PGM2 INPUT LEVEL		-20, <b>0</b> , +4 dBu	Sets the PGM2 input level.	
PGM3 INPUT LEVEL		-20, <b>0</b> , +4 dBu	Sets the PGM3 input level.	

AUDIO/INTERCOM			
Page name Page No.	Item	Set value	Description
<FRONT INTERCOM> A04	MIC/PGM	(PGM ON), (MIC OFF), (MIC ON)	Front panel MIC/PGM switch position (Display only)
	I/F	(PROD), (ENG), (PRIVATE)	Front panel INTERCOM switch position. (Display only)
	PRIVATE SW	<b>ENABLE</b> , DISABLE(SET TO ENG), DISABLE(SET TO PROD)	Operation when the INTERCOM switch on the front panel is set to the PRIV (private) position. <b>ENABLE</b> : Private operation <b>DISABLE(SET TO ENG)</b> : ENG line operation
	INTERCOM MIC	<b>DYNAMIC</b> , ECM, CARBON	Sets the headset microphone connected to the INTERCOM connector on the front panel. <b>CARBON</b> : Carbon microphone (power supply, 20 dB gain) <b>ECM</b> : Electret condenser microphone (power supply, 40 dB gain) <b>DYNAMIC</b> : Dynamic microphone (no power supply, 60 dB gain)
	INTERCOM MIC TYPE	BALANCED, <b>UNBALANCED</b>	Sets the headset microphone connected to the INTERCOM connector on the front panel. <b>BALANCED</b> : Balanced microphone <b>UNBALANCED</b> : Unbalanced microphone
	INTERCOM MIC GAIN	-6, <b>0</b> , +6 dB	Sets the microphone input gain.
	SIDE TONE LEVEL	0 to 99, <b>50</b>	Sets the side tone level.
	PGM MIX MODE	<b>OFF</b> , INCOM+PGM, L-INCOM/R-PGM	<b>OFF</b> : Signals are not mixed. <b>INCOM+PGM</b> : INCOM and PGM signals are mixed. <b>L-INCOM/R-PGM</b> : Outputs INCOM signal through the left channel and PGM signal through the right.
	PGM SELECT	<b>PGM1</b> , PGM2, PGM3, PGM1+PGM2+PGM3	Selects the PGM audio output from the FRONT INTERCOM connector.
	PGM1 LEVEL	0 to 99, <b>50</b>	Sets the MIX level of PGM1.
	PGM2 LEVEL	0 to 99, <b>50</b>	Sets the MIX level of PGM2.
	PGM3 LEVEL	0 to 99, <b>50</b>	Sets the MIX level of PGM3.
	<TEST TONE> A05	SOURCE	1kHz
LEVEL		0, -10, <b>-20</b> , -30, -40, -50, -60, -70 [dB]	Sets the level of the test tone.
ANALOG OUT CH		<b>NONE</b> , ALL, MIC1, MIC2, AES/EBU1, AES/EBU2, INTERCOM ENG, INTERCOM PROD	Sets the analog output channel of the test tone.
IP OUT CH		<b>NONE</b> , ALL, MIC1, MIC2, AES/EBU1, AES/EBU2, INTERCOM ENG, INTERCOM PROD	Sets the IP output channel of the test tone.

AUDIO/INTERCOM			
Page name Page No.	Item	Set value	Description
<IP AUDIO> A06 Displayed only when HKCU-SFP50 is installed.	AUDIO OUT		
	FORMAT	L24/48kHz/1ms/2ch, L24/48kHz/ 1ms/4ch, L24/48kHz/1ms/8ch, L24/48kHz/0.125ms/2ch, L24/ 48kHz/0.125ms/4ch, L24/48kHz/ 0.125ms/8ch, <b>L24/48kHz/ 0.125ms/16ch</b>	Sets the audio format.
	CH ORDER	MIC1, MIC2, AES/EBU1, AES/EBU2	Displays the channel order.
	HD TRUNK AUDIO OUT		
	FORMAT	L24/48kHz/1ms/2ch, L24/48kHz/ 1ms/4ch, L24/48kHz/1ms/8ch, L24/48kHz/0.125ms/2ch, L24/ 48kHz/0.125ms/4ch, L24/48kHz/ 0.125ms/8ch, <b>L24/48kHz/ 0.125ms/16ch</b>	Sets the audio format.
	CH ORDER	THROUGH	Displays the channel order.
	PGM IN		
	FORMAT	L24/48kHz/1ms/2ch, L24/48kHz/ 1ms/4ch, L24/48kHz/1ms/8ch, L24/48kHz/0.125ms/2ch, L24/ 48kHz/0.125ms/4ch, L24/48kHz/ 0.125ms/8ch, <b>L24/48kHz/ 0.125ms/16ch</b>	Sets the audio format.
	CH ORDER	PGM1, PGM2, PGM3	Displays the channel order.
	<IP INTERCOM>		
A07 Displayed only when HKCU-SFP50 is installed.	INTERCOM OUT		
	FORMAT	L24/48kHz/1ms/2ch, L24/48kHz/ 1ms/4ch, L24/48kHz/1ms/8ch, <b>L24/48kHz/0.125ms/2ch</b> , L24/ 48kHz/0.125ms/4ch, L24/48kHz/ 0.125ms/8ch, L24/48kHz/0.125ms/ 16ch	Sets the audio format.
	CH ORDER	ENG, PROD	Displays the channel order.
	INTERCOM IN		
	FORMAT	L24/48kHz/1ms/2ch, L24/48kHz/ 1ms/4ch, L24/48kHz/1ms/8ch, <b>L24/48kHz/0.125ms/2ch</b> , L24/ 48kHz/0.125ms/4ch, L24/48kHz/ 0.125ms/8ch, L24/48kHz/0.125ms/ 16ch	Sets the audio format.
	CH ORDER	ENG, PROD	Displays the channel order.

# MAINTENANCE Menu

MAINTENANCE				
Page name Page No.	Item	Set value	Description	
<TRUNK/PROMPTER> M01	TRUNK LINE			
	CHANNEL MODE	<b>2CH(MAX 75Kbps)</b> , 1CH(MAX 150Kbps)	Sets the number of channels to be used.	
	INTERFACE	<b>232C</b> , 422A	Sets the communication line mode.	
	PROMPTER CH	<b>2CH</b> , 1CH	Sets the number of prompter lines.	
<b>Note</b>				
The number of lines will vary depending on the number of prompter lines of the connected camera.				
<TRUNK/PROMPTER2> M02	NETWORK TRUNK	<b>OFF</b> , NETWORK, NETWORK+VIDEO	Sets the mode for the network trunk. <b>OFF</b> : NETWORK TRUNK is not used. <b>NETWORK</b> : Network Trunk is used (maximum 1 Gbps) <b>NETWORK+VIDEO</b> : Network trunk is used at the same time as HD Trunk/HD Prompter (maximum 100 Mbps)	
	<b>Note</b>			
	When <CAMERA I/F> → FIBER TRANSMIT RATE is set to ULTRA, this is set to NETWORK+VIDEO (fixed).			
	DATA RATE	100Mbps, 1Gbps	Displays the data transfer rate.	
	<b>Note</b>			
	When <CAMERA I/F> → FIBER TRANSMIT RATE is set to ULTRA, this item can be set.			
	CAMERA	ENABLE, DISABLE	Displays whether the camera is enabled/disabled (Display only).	
	HD/UHD TRUNK	ENABLE, DISABLE	Displays whether HD TRUNK is enabled/disabled (Display only).	
	DATA RATE	<b>1.5G</b> , 12G	Displays the HD TRUNK data rate.	
	HD PROMPTER	ENABLE, DISABLE	Displays whether HD PROMPTER is enabled/disabled (Display only). Fixed to DISABLE when using SDI-RET on HDCU5000/5500.	
	FRAME SYNC	OFF, ON, (ON)	Turns the frame synchronizer function ON/OFF.	
	SOURCE	<b>SDI-I/O4</b> , IP-RET3	Sets the HD prompter signal source. IP-RET3 can be selected only when the HKCU-SFP50 ST 2110 Interface Kit is installed.	
	UHD PROMPTER	ENABLE, DISABLE	Displays whether UHD prompter is enabled/disabled (Display only).	
	DATA RATE	<b>1.5G</b> , 3G, 6G, 12G	Sets the UHD prompter data rate.	
	FRAME SYNC	<b>OFF</b> , ON, (ON)	Turns the frame synchronizer function ON/OFF.	
SOURCE	<b>UHD-SDI D</b>	Sets the UHD prompter signal source.		



MAINTENANCE			
Page name Page No.	Item	Set value	Description
<MENU SETTINGS> M03	PAGE RESUME	<u>ON</u> , OFF	Turns the menu mode resume page display function ON/OFF.
	ALARM JUMP	ON, <u>OFF</u>	Turns the error-related page display function ON/OFF for when an error occurs while in menu mode.
	CAMERA MENU CTRL	<u>OFF</u> , ON	Displays the camera menu.
			<p><b>Notes</b></p> <ul style="list-style-type: none"> <li>• If CAM MENU is set to ON, CCU menu operations cannot be performed because only camera menu operations are available.</li> <li>• The camera menu is not displayed when SD signal is output.</li> </ul>
<DATE&TIME> M04	DATE (YEAR)	17 to 99	Sets the date and time.
	DATE (MONTH)	1 to 12	<p><b>Note</b></p> <p>When this is changed, all logs stored on the unit will be deleted.</p>
	DATE (DAY)	1 to 31	
	TIME (HOUR)	0 to 23	
	TIME (MINUTE)	0 to 59	
	TIME ZONE (HOUR)	-23 to +23, <u>0</u>	Sets the time zone.
	TIME ZONE (MINUTE)	<u>0</u> to 59	
<TALLY INPUT> M05	R-TALLY	<u>CONTACT</u>	RED tally input setting
	<p><b>Note</b></p> <p>This is set to CONTACT (fixed).</p>		
	G-TALLY	<u>CONTACT</u>	GREEN tally input setting
			<p><b>Note</b></p> <p>This is set to CONTACT (fixed).</p>
	Y-TALLY	<u>CONTACT</u>	YELLOW tally input setting
			<p><b>Note</b></p> <p>This is set to CONTACT (fixed).</p>
<ALARM SETTINGS> M06	FORCE LEGACY	OFF, <u>ON</u>	Set to OFF to not display the FORCE LEGACY alarm.
	CABLE OPEN	OFF, <u>ON</u>	Set to OFF to not display the CABLE OPEN alarm.
	GENLOCK ERROR	OFF, <u>ON</u>	Set to OFF to not display the GENLOCK ERROR alarm.
<SDI ANCILLARY DATA> M07	VIDEO PAYLOAD ID	<u>LATEST</u> , 2002, 2010, 2011, 2017	Selects the standard year of the payload ID to be added to the SDI VIDEO output.
	EMBED AUDIO	OFF, <u>ON</u>	Sets whether to embed audio in the SDI VIDEO output.
	EMBED META DATA	OFF, <u>ON</u>	
<FRONT PANEL> M08	ASSIGNABLE SWITCH	<u>NONE</u> , BARS, CAM POWER, FORCE LEGACY, OPTICAL SIGNAL	<p>Sets the function to be assigned to the assignable button on the front panel.</p> <p><b>NONE:</b> No assignment.</p> <p><b>BARS:</b> Sets the color bar output to ON/OFF.</p> <p><b>CAM POWER:</b> Sets camera power to ON/OFF.</p> <p><b>FORCE LEGACY:</b> Forces the communication mode to LEGACY mode.</p> <p><b>OPTICAL SIGNAL:</b> Turns the optical signal output from the CCU to the camera ON/OFF.</p>
	SIGNAL BAR		
	DISPLAY	OFF, <u>ON</u>	Switches the signal bar display on the front panel.
	READY COLOR	<u>WHITE</u> , GREEN, BARS	Sets the color for the ready status (during color bar output).
	BRIGHTNESS	LOW, MIDDLE, <u>HIGH</u>	Sets the signal bar brightness level.

MAINTENANCE			
Page name Page No.	Item	Set value	Description
<OPTION> M09	READ KEY FROM USB	Execute using ENTER.	Reads the installation key from the USB flash drive.
	INSTALLED OPTIONS		Lists the installed option software (Display only).
	HARDWARE OPTIONS		Lists the installed hardware options (Display only).
<MISC> M10	OPTICAL SIGNAL BACKUP	ENABLE, <b>DISABLE</b>	Sets whether to save the state of the OPTICAL SIGNAL setting on the <CAMERA I/F> page of the SYSTEM CONFIG menu for the next startup.
	UHB LIVE HDR	BASIC, <b>ADVANCED</b>	Sets the Live HDR mode for HDC5000/5500.

## FILE Menu

FILE			
Page name Page No.	Item	Set value	Description
<CCU FILE> F01	FILE INDEX	1 to 5, <b>1</b>	Selects the file number of the target for operation.
	RECALL		All menu settings of the unit can be saved to a CCU file. Use RECALL to load and apply the saved settings to simplify the setup operation.
			<b>Note</b>
			The IP address, subnet mask, and default gateway settings of the LAN COM connector are not loaded using RECALL.
	STORE		Saves a CCU file to the internal memory. Up to five CCU files can be saved in the unit. Select the file number on the STORE screen.
	EXPORT TO USB		Exports a CCU file to the USB flash drive. Exporting is also supported using the web menu. The path for the USB flash drive is "/MSSONY/PRO/CAMERA/HDCU5000"
	IMPORT FROM USB		Imports a CCU file from the USB flash drive. Importing is also supported using the web menu. The path for the USB flash drive is "/MSSONY/PRO/CAMERA/HDCU5000"
	FILE NAME1 to 5	NO_FILE	Sets the CCU file name. ASCII code, 1 to 32 characters
	CLEAR ALL		Deletes all CCU files.
	<LOG> F02	LOG	<b>ENABLE</b> , DISABLE
EXPORT TO USB			Saves logs to the USB flash drive (Execute using EXEC). The path of the USB flash drive is "/MSSONY/PRO/CAMERA/HDCU5000"
CLEAR			Deletes logs stored internally on the unit (Execute using EXEC).
		<b>Note</b>	
		Logs for up to 30 days are stored. Logs are deleted when the 30-day maximum is reached, starting with the oldest.	

## NETWORK Menu

NETWORK				
Page name Page No.	Item	Set value	Description	
<IP ADDRESS> N01	PORT	LAN-COM, LAN1, LAN2	Selects the port for which to set the IP address.	
	DHCP	<u>ON</u> , OFF	Enables or disables DHCP.	
	IP ADDRESS	<u>0.0.0.0</u> to 255.255.255.255	Sets the IP address.	
				<p><b>Note</b></p> <p>If there is no DHCP server available on the network when DHCP is set to ON, a unique Link-Local address (169.254.0.0/16) is assigned locally by the Auto IP function. If an IP address is assigned to the DHCP server, the Auto IP function will not be activated while the unit is operating (powered) in order to prevent incorrect operation, even if communication with the DHCP server is subsequently interrupted. This IP address may change if the unit is restarted, and should only be used for setup purposes. The Auto IP function applies only to the LAN COM connector. It does not apply to the LAN 1 and LAN 2 connectors of the HKCU-SFP50.</p>
	SUBNET MASK	<u>0.0.0.0</u> to 255.255.255.255	Sets the subnet mask.	
	DEFAULT GATEWAY	<u>0.0.0.0</u> to 255.255.255.255	Sets the default gateway.	
	SET	A "SET OK?" message is displayed. Press ENTER again to confirm the change. (Execute using ENTER)		
	COPY TO STATIC ADDRESS	Copies the IP ADDRESS, SUBNET MASK, and DEFAULT GATEWAY settings obtained with DHCP set to ON to the static settings when DHCP is set to OFF.		
	MAC ADDRESS	<u>000000000000</u> to ffffffff	Displays the MAC address of each port.	
	LINK SPEED	10G, <u>25G</u>	Displays the link speed. Displayed only when LAN1 or LAN2 is selected.	
			<p><b>Note</b></p> <p>Always set LAN1 and LAN2 to the same link speed. Normal operation will not occur if the settings are different.</p>	
<CNS SETTINGS> N02	25G FEC	OFF, <u>RS-FEC(CL108)</u> , FC-FEC(CL74)	Sets the FEC mode for 25G. Displayed only when LAN1 or LAN2 is selected.	
				<p><b>Note</b></p> <p>Set to the port setting of the IP switch to be connected.</p>
	CNS MODE	<u>LEGACY</u> , BRIDGE, MCS	Sets the communication mode.	
	MCS MODE	CLIENT	Indicates that the unit is the client when MCS mode is selected (Display only).	
	CCU NO	When MCS is selected in CNS MODE: Blank, 1 to 96 When LEGACY or BRIDGE is selected in CNS MODE: Blank, 1 to 96, A to Z	Sets the CCU number.	
<CNS SETTINGS> N02	MASTER IP ADDRESS	<u>0.0.0.0</u> to 255.255.255.255	Sets the master device IP address for MCS mode.	
	SET	A "SET OK?" message is displayed. Press ENTER again to confirm the change. (Execute using ENTER)		

NETWORK				
Page name Page No.	Item	Set value	Description	
<WEB MENU> N03	WEB MENU	<b>ENABLE</b> , DISABLE	Enables/disables the web menu.	
	PORT	<b>LAN-COM</b>	Selects the connection port.	
	SERVICE DISCOVERY	<b>ON</b> , OFF	Enables/disables the service discovery function. <b>ON</b> : Display the CCU list in the web menu. <b>OFF</b> : Do not display the CCU list in the web menu.	
<b>Notes</b>				
<ul style="list-style-type: none"> <li>Set this to OFF if the CCU list is not required or when you want to reduce the network load as much as possible.</li> <li>When set to OFF, the unit cannot be detected by the service discovery from other CCUs on the same subnet.</li> </ul>				
<NETWORK GENLOCK> N04 Displayed only when HKCU-SFP50 is installed.	PORT	LAN1, LAN2	Selects the port to use.	
	NETWORK GENLOCK	DISABLE, <b>ENABLE</b>	Enables/disables network genlock.	
	PROFILE	ST2059-2	Displays the supported profile. Only the ST2059-2 profile is supported.	
	DOMAIN NUMBER	0 to 127, <b>127</b>	Sets the domain number.	
	<b>Note</b>			
	Set to the domain number of the master device to be connected.			
	COMMUNICATION MODE	<b>MULTICAST MODE</b> , MIXED MODE	<b>MIXED MODE</b> : Unicast reply to the master. <b>MULTICAST MODE</b> : Multicast reply to the master.	
	DELAY REQUEST INTERVAL	-7 to -1, <b>-3</b>	Displays the delay of the response to the PTP master.	
	PTP MASTER INFO			Displays information obtained from the PTP master.
	IP ADDRESS	0.0.0.0 to 255.255.255.255	Displays the IP address of the currently synchronized PTP master device.	
	SYNC INTERVAL	-7 to -1, <b>-3</b>	Displays the Sync Interval setting of the master device.	
PRIORITY 1	0 to 255, <b>128</b>	Displays the priority level of the PTP master.		
PRIORITY 2	0 to 255, <b>128</b>	The lower the number, the higher the priority.		
STEP	ONE-STEP, <b>TWO-STEP</b>	Displays the mode in which the timestamp is sent. <b>ONE-STEP</b> : Sent in Sync message. <b>TWO-STEP</b> : Sent in Follow-up message.		
LOCK STATUS	<b>NOT IN USE</b> , NO MASTER, LOCKING, LOCKED	Displays the genlock operation status. <b>NOT IN USE</b> : PTP operation stopped <b>NO MASTER</b> : PTP master not found <b>LOCKING</b> : Synchronizing <b>LOCKED</b> : Synchronized		

NETWORK			
Page name Page No.	Item	Set value	Description
<PTP STATUS> N05 Displayed only when HKCU-SFP50 is installed.	PTP NIC	LAN1, LAN2	Displays the port on which PTP is running.
	STATUS	NO MASTER, LOCKED, LOCKING, NOT IN USE	Displays the PTP status. <b>NOT IN USE:</b> PTP operation stopped <b>NO MASTER:</b> PTP master not found <b>LOCKING:</b> Synchronizing <b>LOCKED:</b> Synchronized
	PORT	LAN1, LAN2	Selects the port for which to display the status.
	UTC Time	1970-01-01 00:00:00	Master time (displays the internal time when the master is Free-run or Disable).
	MasterID	0000000000000000-0	Displays the master clock ID.
	GMClockID	0000000000000000-0	Displays the grandmaster clock ID.
	Sync	0Hz (0pkts)	Displays the sync message rate.
	FollowUp	0Hz (0pkts)	Displays the follow-up message rate.
	DelayReq	0Hz (0pkts)	Displays the delay request message rate.
	DelayResp	0Hz (0pkts)	Displays the delay response message rate.
	Network Status	UNAVAILABLE, NOT GOOD, GOOD, VERY GOOD	Displays the network status.
	Delay	0ns	Displays the network delay.
	Jitter	0ns	Displays the network jitter.
	<IP LIVE> N06 Displayed only when HKCU-SFP50 is installed.	IP LIVE SYSTEM MANAGER	
PORT		DISABLE, <b>LAN1&amp;LAN2</b>	Sets the IP Live System Manager (LSM). <b>DISABLE:</b> Does not communicate with LSM. <b>LAN1&amp;LAN2:</b> Communicates with LSM using LAN1 and LAN2 (for redundancy).
<b>Note</b> Restart the unit after changing the PORT setting.			
DHCP		<b>OFF</b>	Sets the IP address of the LSM (fixed OFF).
PRIMARY IP ADDRESS		<b>0.0.0.0</b> to 255.255.255.255	Sets the IP address of LSM1.
SECONDARY IP ADDRESS		<b>0.0.0.0</b> to 255.255.255.255	Sets the IP address of LSM2.
PRIMARY CONNECTION STATUS		<b>DISCONNECTED</b> , CONNECTING, CONNECTED	Displays the status of the connection with LSM1. <b>DISCONNECTED:</b> Disconnected. <b>CONNECTING:</b> Establishing communication. <b>CONNECTED:</b> Communication established.
SECONDARY CONNECTION STATUS		<b>DISCONNECTED</b> , CONNECTING, CONNECTED	Displays the status of the connection with LSM2. <b>DISCONNECTED:</b> Disconnected. <b>CONNECTING:</b> Establishing communication. <b>CONNECTED:</b> Communication established.
MULTICAST ADDRESS		<b>AUTO</b> , MANUAL	Sets the mode switching method for the multicast address setting of IP stream. Fixed to AUTO when PORT is set to LAN1&LAN2, and uses multicast addresses configured from the LSM. Fixed to MANUAL when PORT is set to DISABLE, and uses the addresses set manually using the MULTICAST ADDRESS 1 to 5 pages.
HITLESS FAILOVER		<b>ON</b> , OFF	Enables/disables IP stream redundancy.

NETWORK			
Page name Page No.	Item	Set value	Description
<NMOS> N07 Displayed only when HKCU-SFP50 is installed.	PORT	<b>DISABLE</b> , LAN-COM	Selects the ports on which NMOS is enabled. Can be selected only when <IP LIVE> → IP LIVE SYSTEM MANAGER → PORT is set to DISABLE.
	PORT NUMBER (IS-04 NODE)	100 to 65535, <b>3001</b>	Sets the port number for the IS-04 Node API.
	PORT NUMBER (IS-05 CONNECTION)	100 to 65535, <b>3002</b>	Sets the port number for the IS-05 Connection API.
	RDS DISCOVERY	<b>ON</b> , OFF	Enables/disables auto detection using the Registration & Discovery System (RDS). When enabled, RDS discovery is enabled within the same subnet.
			<b>Note</b>
			If RDS is not available on the same subnet, disable the setting and set the IP address manually.
	RDS CONNECTION STATUS	<b>DISCONNECTED</b> , CONNECTING, CONNECTED	Displays the RDS connection status.
	RDS IP ADDRESS	<b>0.0.0.0</b> to 255.255.255.255	Displays the detected RDS IP address when RDS DISCOVERY is set to ON. Sets the RDS IP address manually when RDS DISCOVERY is set to OFF.
	RDS PORT NUMBER	100 to 65535, <b>18235</b>	Displays the detected RDS port when RDS DISCOVERY is set to ON. Sets the RDS port manually when RDS DISCOVERY is set to OFF.
<MULTICAST ADDRESS 1> N08 Displayed only when HKCU-SFP50 is installed.	MULTICAST ADDRESS	<b>AUTO</b> , MANUAL	Displays the mode of the multicast address setting of the IP stream.
	VIDEO OUT LAN1-1		<b>Note</b>
			Displayed on the HDCU3500 only when the HZCU-UHD35 option is enabled.
	IP ADDRESS	224.0.0.1 to 239.255.255.255	Displays the destination IP address.
	PORT	<b>100 to 65535</b>	Displays the transmit destination port number.
	VIDEO OUT LAN1-2		Same setting items and values as VIDEO OUT LAN1-1.
	VIDEO OUT LAN1-3		Same setting items and values as VIDEO OUT LAN1-1.
	VIDEO OUT LAN1-4		Same setting items and values as VIDEO OUT LAN1-1.
	VIDEO OUT LAN2-1		Same setting items and values as VIDEO OUT LAN1-1.
	VIDEO OUT LAN2-2		Same setting items and values as VIDEO OUT LAN1-1.
	VIDEO OUT LAN2-3		Same setting items and values as VIDEO OUT LAN1-1.
	VIDEO OUT LAN2-4		Same setting items and values as VIDEO OUT LAN1-1.
			<b>Note</b>
			Displayed on the HDCU3500 only when the HZCU-UHD35 option is enabled.

NETWORK				
Page name Page No.	Item	Set value	Description	
<MULTICAST ADDRESS 2-1> N09 Displayed only when HKCU-SFP50 is installed.	MULTICAST ADDRESS	<b>AUTO</b> , MANUAL	Displays the MULTICAST ADDRESS setting of the <MULTICAST SETTING> page.	
	RETURN LAN1-1		<b>Note</b> Displayed on the HDCU3500 only when the HZCU-UHD35 option is enabled.	
	IP ADDRESS	224.0.0.1 to 239.255.255.255	Displays the receive destination IP address.	
	PORT	<b>100 to 65535</b>	Displays the receive destination port number.	
	SRC IP	<b>0.0.0.0</b> to 255.255.255.255	Displays the stream transmit source IP address.	
	RETURN LAN1-2		Same setting items and values as RETURN LAN1-1.	
	RETURN LAN1-3		Same setting items and values as RETURN LAN1-1.	
	RETURN LAN1-4		Same setting items and values as RETURN LAN1-1.	
			<b>Note</b> Displayed on the HDCU3500 only when the HZCU-UHD35 option is enabled.	
<MULTICAST ADDRESS 2-2> N09 Displayed only when HKCU-SFP50 is installed.	MULTICAST ADDRESS	<b>AUTO</b> , MANUAL	Displays the MULTICAST ADDRESS setting of the <MULTICAST SETTING> page.	
	RETURN LAN2-1			
	IP ADDRESS	224.0.0.1 to 239.255.255.255	Displays the receive destination IP address.	
	PORT	<b>100 to 65535</b>	Displays the receive destination port number.	
	RETURN LAN2-2		Same setting items and values as RETURN LAN2-1.	
	RETURN LAN2-3		Same setting items and values as RETURN LAN2-1.	
	RETURN LAN2-4		Same setting items and values as RETURN LAN2-1.	
<MULTICAST ADDRESS 3> N10 Displayed only when HKCU-SFP50 is installed.	MULTICAST ADDRESS	<b>AUTO</b> , MANUAL	Displays the MULTICAST ADDRESS setting of the <MULTICAST SETTING> page.	
	AUDIO OUT LAN1			
	IP ADDRESS	224.0.0.1 to 239.255.255.255	Displays the transmit destination IP address.	
	PORT	<b>100 to 65535</b>	Displays the transmit destination port number.	
	AUDIO OUT LAN2		Same setting items and values as AUDIO OUT LAN1.	
	HD TRUNK AUDIO OUT LAN1		Same setting items and values as AUDIO OUT LAN1.	
	HD TRUNK AUDIO OUT LAN2		Same setting items and values as AUDIO OUT LAN1.	
	PGM IN LAN1			
	IP ADDRESS	224.0.0.1 to 239.255.255.255	Displays the receive destination IP address.	
	PORT	<b>100 to 65535</b>	Displays the receive destination port number.	
	SRC IP	<b>0.0.0.0</b> to 255.255.255.255	Displays the stream transmit source IP address.	
	PGM IN LAN2		Same setting items and values as PGM IN LAN1.	
<MULTICAST ADDRESS 4> N11 Displayed only when HKCU-SFP50 is installed.	MULTICAST ADDRESS	<b>AUTO</b> , MANUAL	Displays the MULTICAST ADDRESS setting of the <MULTICAST SETTING> page.	
	INTERCOM OUT LAN1			
	IP ADDRESS	224.0.0.1 to 239.255.255.255	Displays the transmit destination IP address.	
	PORT	<b>100 to 65535</b>	Displays the transmit destination port number.	
	INTERCOM OUT LAN2		Same setting items and values as INTERCOM OUT LAN1.	
	INTERCOM IN LAN1			
	IP ADDRESS	224.0.0.1 to 239.255.255.255	Displays the receive destination IP address.	
	PORT	<b>100 to 65535</b>	Displays the receive destination port number.	
	SRC IP	<b>0.0.0.0</b> to 255.255.255.255	Displays the stream transmit source IP address.	
	INTERCOM IN LAN2		Same setting items and values as INTERCOM IN LAN1.	

NETWORK			
Page name Page No.	Item	Set value	Description
<MULTICAST ADDRESS 5> N12 Displayed only when HKCU-SFP50 is installed.	MULTICAST ADDRESS	<b>AUTO</b> , MANUAL	Displays the MULTICAST ADDRESS setting of the <MULTICAST SETTING> page.
	META OUT LAN1-1		
	IP ADDRESS	224.0.0.1 to 239.255.255.255	Displays the transmit destination IP address.
	PORT	<b>100 to 65535</b>	Displays the transmit destination port number.
	META OUT LAN1-2		Same setting items and values as META OUT LAN1-1.
	META OUT LAN1-3		Same setting items and values as META OUT LAN1-1.
	META OUT LAN2-1		Same setting items and values as META OUT LAN1-1.
	META OUT LAN2-2		Same setting items and values as META OUT LAN1-1.
<EMBER+> N13	EMBER+	<b>DISABLE</b> , ENABLE	Enables/disables configuration using Ember+.
			<b>Note</b> Can be enabled by installing HZCU-CNFG50 Config Control Software (option).
	PORT	<b>LAN-COM</b>	Displays the connection port name.
	PORT NUMBER	<b>9000</b>	Displays the TCP port number for the Ember+ connection.
	CONNECTION STATUS	<b>DISCONNECTED</b> , CONNECTING, CONNECTED	Displays the connection status of Ember+ communication. <b>DISCONNECTED:</b> Disconnected. <b>CONNECTING:</b> Establishing communication. <b>CONNECTED:</b> Communication established.
<TSL UMD> N14	TSL UMD	<b>DISABLE</b> , ENABLE	Enables/disables IP Tally using TSL UMD V5.0.
	PORT	<b>LAN-COM</b>	Displays the connection port name.
	PORT NUMBER	<b>8900</b>	Displays the UDP port number of the TSL UMD connection.
	PACKET STATUS	<b>NOT RECEIVED</b> , RECEIVED	Displays the TSL UMD packet reception status. When received, it also displays IDs and the on/off status of the red, green, and yellow tallies. Up to five IDs can be displayed. "AND MORE" is displayed if there are more.



NETWORK			
Page name Page No.	Item	Set value	Description
<SNMP> N15	SNMP	ENABLE, <b>DISABLE</b>	Enables/disables SNMP.
	<b>Note</b>		
	Can be enabled by installing HZCU-SNMP50 SNMP Agent Software (option).		
	PORT	<b>LAN-COM</b>	Displays the connection port name.
	NAME		Displays the system name (ASCII code, up to 32 characters).
	CONTACT		Displays the system administrator's name (ASCII code, up to 32 characters).
	LOCATION		Displays the system installation location (ASCII code, up to 32 characters).
	V1		
	ENABLE	ENABLE, <b>DISABLE</b>	Enables/disables SNMP V1.
	V2C		
	ENABLE	ENABLE, <b>DISABLE</b>	Enables/disables SNMP V2C.
	V1/V2C		
	RO COMMUNITY	<b>sony</b>	Displays the ReadOnly community name (ASCII code, up to 32 characters).
	ALLOW HOST	<b>ANY</b> , SPECIFIC	Sets the hosts that can be connected. <b>ANY:</b> Allow access from all IP addresses. <b>SPECIFIC:</b> Allow access only from IP addresses configured using the HOST IP ADDRESS items.
HOST1 IP ADDRESS	<b>0.0.0.0</b> to 255.255.255.255	Sets the address of a host that can connect with access permission when ALLOW HOST is set to SPECIFIC.	
HOST2 IP ADDRESS			
HOST3 IP ADDRESS			
<SNMP TRAP> N16	SNMP TRAP	ENABLE, <b>DISABLE</b>	Enables/disables SNMP traps. Selectable when SNMP is enabled. Fixed to DISABLE when SNMP is disabled.
	COMMUNITY		Displays the trap community name (ASCII code, up to 32 characters).
	HOST1		
	IP ADDRESS	<b>0.0.0.0</b> to 255.255.255.255	Sets the trap notification address.
	VERSION	V1, V2C	Sets the trap version.
	HOST2		Same setting items and values as HOST1.
	HOST3		Same setting items and values as HOST1.
	SEND TEST TRAP	<b>EXEC</b>	Sends a test trap.

NETWORK			
Page name Page No.	Item	Set value	Description
<PING> N17	PORT	<b>LAN-COM</b> , LAN1, LAN2	Selects the PING transmission destination port.
	<b>Note</b>		
	LAN1 and LAN2 are available only when HKCU-SFP50 is installed.		
	IP ADDRESS	<b>0.0.0.0</b> to 255.255.255.255	Sets the IP address of the PING transmit destination.
	PING		PING transmission. (Execute using EXEC)
	STATISTICS		Displays the PING execution result.
	TRANSMITTED PACKETS	<b>0</b> to 5	Number of transmitted packets.
	RECEIVED PACKETS	<b>0</b> to 5	Number of received packets.
	PACKET LOSS	<b>0</b> to 100 %	Packet loss rate.
	ROUND-TRIP MIN	<b>0.0</b> to 1000000.0 ms	Minimum round-trip delay time.
ROUND-TRIP AVERAGE	<b>0.0</b> to 1000000.0 ms	Average round-trip delay time.	
ROUND-TRIP MAX	<b>0.0</b> to 1000000.0 ms	Maximum round-trip delay time.	

## DIAGNOSIS Menu

DIAGNOSIS			
Page name Page No.	Item	Display	Description
<BOARD STATUS> D01	VIF	OK, POWER ERROR, PLD ERROR, TEMP WARNING	VIF board self-diagnostics result
	TX	OK, POWER ERROR, PLD ERROR, TEMP WARNING	TX board self-diagnostics result
	NET	OK, POWER ERROR, PLD ERROR, TEMP WARNING	HKCU-SFP50 board (option) self-diagnostics result
	POWER ON HOUR METER	99999 H	Accumulated power-on time from power on.
	HOURLY METER	99999 H	Accumulated power-on time
<SERIAL NUMBER> D02	MODEL NAME		Unit model name
	SERIAL NUMBER		Serial number
<VERSION> D03	APPLICATION		Unit software version
	OS		Unit software version
	UPDATER		Unit software version
	SY		ROM version of SY PLD (SY board)
	VIF		ROM version of VIF PLD (VIF board)
	TX1(HIGH)		ROM version of TX1 PLD (HIGH) (HKCU-FB50 board option)
	TX1(ULTRA)		ROM version of TX1 PLD (ULTRA) (HKCU-FB50 board option)
	TX2		ROM version of TX2 PLD (HKCU-FB50 board option)
	NET1		ROM version of NET1 PLD (HKCU-SFP50 board option)
	NET2		ROM version of NET2 PLD (HKCU-SFP50 board option)
<CAMERA DIAGNOSIS> D04	NAME		Model name of connected camera
	ROM VERSION	X.XX	ROM version of camera

<b>DIAGNOSIS</b>			
<b>Page name Page No.</b>	<b>Item</b>	<b>Display</b>	<b>Description</b>
<POWER UNIT STATUS> D05	CAM POWER SUPPLY	ON, OFF	Displays the status of power supply to the camera.
	CABLE OPEN	OK, OPEN	Displays the cable open-circuit status.
	CABLE SHORT	OK, SHORT	Displays the cable short-circuit status.
	RCP POWER	OK, ERROR	Displays the status of power supply to the RCP.
<FAN STATUS> D06	PS FAN	OK, STOP	Displays the power supply unit fan operation status (HDCU5500/3500 only).
	PS REAR FAN	OK, STOP	Displays the power supply unit rear fan operation status.
	FRONT FAN1/2	OK, STOP	Displays the operating status of the front panel fans 1 and 2 (HDCU5000 only).
	FRONT FAN4	OK, STOP	Displays the operating status of the front panel fan 4 (HDCU5000 only).
	REAR FAN	OK, STOP	Displays the rear panel fan operation status (HDCU5500/3500 only).
	REAR FAN1/2	OK, STOP	Displays the operating status of rear panel fans 1 and 2 (HDCU5000 only).
	REAR FAN4	OK, STOP	Displays the operating status of rear panel fan 4 (HDCU5000 only).

# Appendix

## Precautions

If the unit is suddenly taken from a cold to a warm location, or if ambient temperature suddenly rises, moisture may form on the outer surface of the unit and/or inside of the unit. This is known as condensation. If condensation occurs, turn off the unit and wait until the condensation clears before operating the unit. Operating the unit while condensation is present may damage the unit.

The fan and battery are consumable parts that will need periodic replacement.

When operating at room temperature, a normal replacement cycle will be about 5 years. However, this replacement cycle represents only a general guideline and does not imply that the life expectancy of these parts is guaranteed. For details on parts replacement, contact your Sony representative.

The life expectancy of the electrolytic capacitor is about 5 years under normal operating temperatures and normal usage (8 hours per day; 25 days per month).

If usage exceeds the above normal usage frequency, the life expectancy may be reduced correspondingly.

## Operating environment

- Avoid high-temperature rooms and near sources of heat.
- Do not place in locations with strong electric or magnetic field.
- Dry location with good ventilation.
- Avoid locations exposed to sunlight or strong lighting.

## Avoid violent impacts

Dropping the unit, or otherwise imparting a violent shock to it, is likely to cause it to malfunction.

## Do not cover with cloth

While the unit is in operation, do not cover it with a cloth or other material. This can cause the temperature to rise, leading to a malfunction.

## After use

Set the POWER switch to the OFF position.

## Care

If the body or panels of the unit become dirty, wipe them with a dry cloth. For severe dirt, use a soft cloth steeped in a small amount of neutral detergent, then wipe dry. Do not use volatile solvents such as alcohol or thinners, as these may damage the finish.

## To prevent electromagnetic interference from portable communications devices

The use of portable telephones and other communications devices near this unit can result in malfunctions and interference with audio and video signals.

It is recommended that the portable communications devices near this unit be powered off.

## Error Messages

When an error is detected in this unit or the camera, the ALARM indicator turns on and an error message is displayed on this unit.

Error Messages	Description
CCU:XXX POWER ERROR	Board power supply error (XXX is the board name)
CCU:XXX PLD ERROR	PLD error (XXX is the board name)
CCU:XXX TEMP WARNING	Board temperature error (XXX is the board name)
CCU:OPTICAL CONDITION OK	Light sensor level on CCU side dropped
CCU:OPTICAL CONDITION WARNING	
CCU:OPTICAL CONDITION CARE	
CCU:OPTICAL CONDITION ERROR	
CCU:PS FAN STOP	Power supply block FAN error
CCU:PS CABLE SHORT	CAMERA connector optical fiber cable short-circuit connection error
CCU:PS CABLE OPEN	CAMERA connector optical fiber cable open-circuit connection error
CCU:PS RCP POWER SUPPLY ERROR	Remote control panel (connected to REMOTE connector) power supply error
CCU:PS TEMP WARNING	Power supply unit temperature error
CCU:PS POWER ERROR	Power supply unit input/output error
CCU:PS POWER WARNING	
CCU:FRONT FAN1 STOP	Front board fan 1 stopped
CCU:PS REAR FAN STOP	Power supply block rear fan error
CCU:GENLOCK ERROR	External reference sync error
CCU:FORCE LEGACY	LEGACY is forcibly set for CNS MODE
CCU:10FIELD-ID ERROR	10-field ID is not detected even though the 10F BB setting is On
CCU:SET DATE&TIME	Invalid date
CCU:LINK SPEED MISMATCH	The link speeds of LAN1 and LAN2 do not match.

# Specifications

## HDCU5000

### General

Power requirements	100/120/220 to 240 V AC, 50/60 Hz (For details about switching the voltage, contact a Sony service or sales representative.)
Current consumption	7 A (max.)
Operating temperature	5 °C to 40 °C (41 °F to 104 °F)
Storage temperature	-20 °C to +60 °C (-4 °F to +140 °F)
Mass	Approx. 19.5 kg (43 lb)

### External dimensions (Unit: mm (inches))

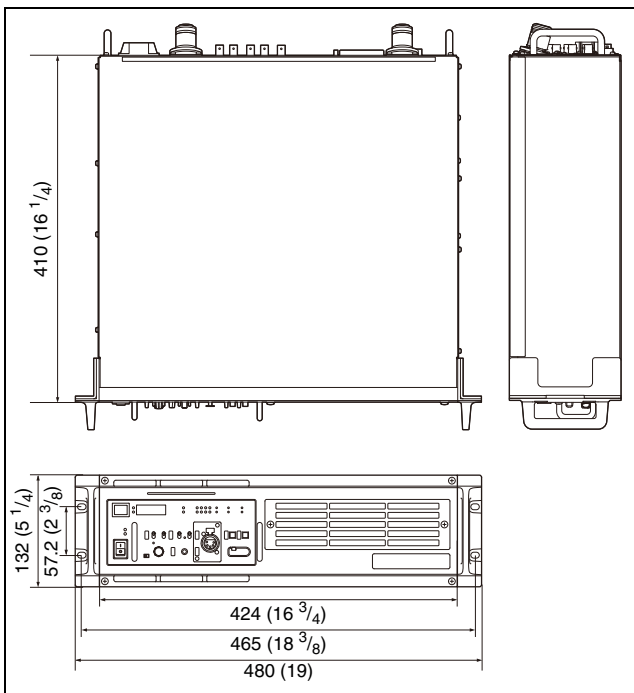

### Input/output connectors

CAMERA FIBER	Optical fiber connector (2)
INTERCOM/TALLY/IO PORT	D-Sub 50-pin connector (1) <ul style="list-style-type: none"> <li>INTERCOM (PROD/ENG), 4W: 0 dBu, RTS: 0 dBu, CC: -14 dBu</li> <li>PGM, 3 systems, 0 dBu/-20 dBu</li> <li>TALLY (R, G, Y)</li> <li>FLAG</li> </ul>
RCP/CNU	8-pin multi-connector (1)
TRUNK	12-pin (1)
LAN COM	8-pin (1)
NETWORK TRUNK	8-pin (1)

SDI I/O 1 to 4	3G/HD/SD SDI I/O BNC type (4) 3G SDI: SMPTE ST424/425 Level-A/B, 0.8 Vp-p, 75 ohms, 2.970 Gbps/2.967 Gbps HD SDI: SMPTE ST292, 0.8 Vp-p, 75 ohms, 1.485 Gbps/1.4835 Gbps SD SDI: SMPTE 259M, 0.8 Vp-p, 75 ohms, 270 Mbps 3G SDI/HD SDI/SD SDI, character signal selectable
----------------	---

REFERENCE IN/OUT	BNC type (2), loop-through output HD: SMPTE ST274, tri-level sync signal, 0.6 Vp-p, 75 ohms SD: Black burst (NTSC: 0.286 Vp-p, 75 ohms/PAL: 0.3 Vp-p, 75 ohms) or NTSC 10F-BB
------------------	---

### Input connectors

AC IN	100/120/220 to 240 V (1) (For details about switching the voltage, contact a Sony service or sales representative.)
SDI RET 1 to 4	BNC type (4) 3G SDI: SMPTE ST424/425, 2.970 Gbps/2.967 Gbps HD SDI: SMPTE ST292, 1.485 Gbps/1.4835 Gbps SD SDI: SMPTE 259M, 270 Mbps
PROMPTER 1 PROMPTER 2/ VBS-RET	BNC type (2), loop-through output during 1CH mode, terminated internally at 75 ohms during 2CH mode, analog signal, 1.0 Vp-p, 75 ohms

### Output connectors

AUDIO OUT CH1, CH2	XLR 3-pin, male (2), 0 dBu/-20 dBu/+4 dBu
CHARACTER/SYNC	BNC type (1), VBS, 1 Vp-p, 75 ohms
AES/EBU	BNC type (1), AES/EBU format
SDI OUT 1 to 4	3G/HD/SD SDI OUTPUT BNC type (4) 3G SDI: SMPTE ST424/425 Level-A/B, 0.8 Vp-p, 75 ohms, 2.970 Gbps/2.967 Gbps HD SDI: SMPTE ST292, 0.8 Vp-p, 75 ohms, 1.485 Gbps/1.4835 Gbps SD SDI: SMPTE 259M, 0.8 Vp-p, 75 ohms, 270 Mbps 3G SDI/HD SDI/SD SDI, character signal selectable
UHD SDI A, B, E, F	12G/6G/3G/HD SDI OUTPUT BNC type (2) 12G SDI: SMPTE ST2082, 0.8 Vp-p, 75 ohms, 11.88 Gbps/11.868 Gbps 6G SDI: SMPTE ST2081, 0.8 Vp-p, 75 ohms, 5.940 Gbps/5.934 Gbps 3G SDI: SMPTE ST424/425 Level-A/B, 0.8 Vp-p, 75 ohms, 2.970 Gbps/2.967 Gbps HD SDI: SMPTE ST292, 0.8 Vp-p, 75 ohms, 1.485 Gbps/1.4835 Gbps

UHD SDI C, D, G, H	12G/6G/3G/HD SDI I/O BNC type (2) 12G SDI: SMPTE ST2082, 0.8 Vp-p, 75 ohms, 11.88 Gbps/11.868 Gbps 6G SDI: SMPTE ST2081, 0.8 Vp-p, 75 ohms, 5.940 Gbps/5.934 Gbps 3G SDI: SMPTE ST424/425 Level-A/B, 0.8 Vp-p, 75 ohms, 2.970 Gbps/ 2.967 Gbps HD SDI: SMPTE ST292, 0.8 Vp-p, 75 ohms, 1.485 Gbps/1.4835 Gbps
--------------------	---

#### Supplied accessories

Number plates (1 set)

Before Using This Unit (1)

Operating Instructions (CD-ROM) (1)

#### Optional accessories

HKCU-SDI50 12G-SDI Extension Kit

HKCU-SFP50 ST 2110 Interface Kit

HKCU-SM50 Single Mode Fiber Connector Kit

HZCU-CNFG50 Config Control Software

HZCU-SNMP50 SNMP Agent Software

HZCU-UHD35 4K/HDR Processor Software

United States and Canada: Power cord set (1-551-812-XX)

Other areas: Power cord set (1-782-929-XX)

United States and Canada: Plug holder B (2-990-242-01)

Other areas: Plug holder C (3-613-640-01)

CCA-5-3 Connection Cable (3 meters), CCA-5-10 Connection  
Cable (10 meters)

Service Manual

#### Related devices

HDC5000/5500 Color Camera

HDC2000 HD Color Camera

HDC2580/2500/2400/1700 HD Color Camera

RCP-3000/1000 series Remote Control Panel

MSU-1000 series Master Setup Unit

## HDCU5500

#### General

Power requirements	100 V to 240 V AC, 50/60 Hz
Current consumption	4.5 A (max.)
Operating temperature	-10 °C to +40 °C (14 °F to 104 °F)
Storage temperature	-20 °C to +60 °C (-4 °F to +140 °F)
Mass	Approx. 6.4 kg (14 lb 1.8 oz)

#### External dimensions (Unit: mm (inches))

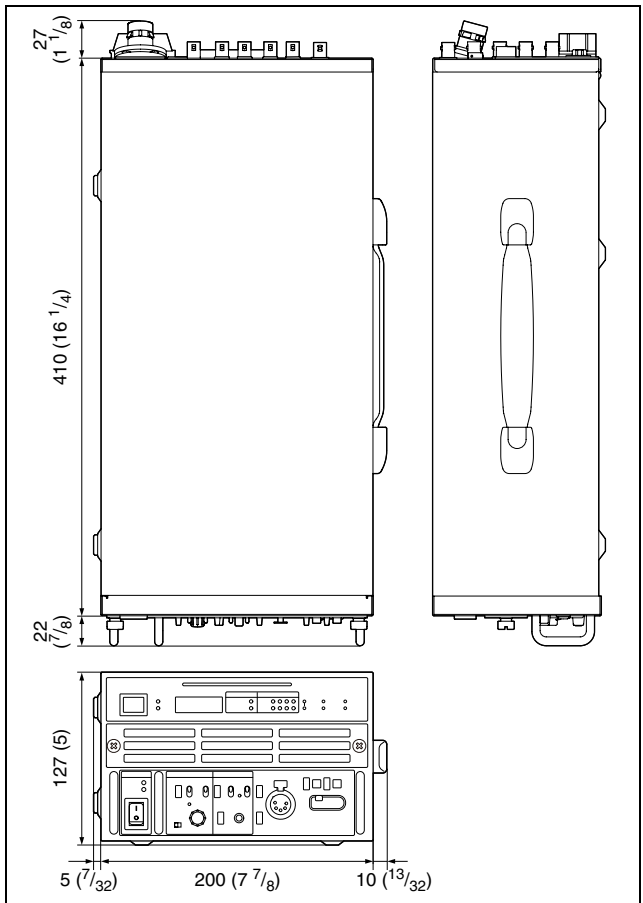

#### Input/output connectors

CAMERA FIBER	Optical fiber connector (1)
INTERCOM/TALLY/ IO PORT	D-Sub 50-pin connector (1) <ul style="list-style-type: none"> <li>INTERCOM (PROD/ENG), 4W: 0 dBu, RTS: 0 dBu, CC: -14 dBu</li> <li>PGM, 3 systems, 0 dBu/-20 dBu</li> <li>TALLY (R, G, Y)</li> <li>FLAG</li> </ul>
RCP/CNU	8-pin multi-connector (1)
TRUNK	12-pin (1)
LAN COM	8-pin (1)
NETWORK TRUNK	8-pin (1)
SDI I/O 1 to 4	3G/HD/SD SDI I/O BNC type (4) 3G SDI: SMPTE ST424/425 Level-A/B, 0.8 Vp-p, 75 ohms, 2.970 Gbps/ 2.967 Gbps HD SDI: SMPTE ST292, 0.8 Vp-p, 75 ohms, 1.485 Gbps/1.4835 Gbps SD SDI: SMPTE 259M, 0.8 Vp-p, 75 ohms, 270 Mbps 3G SDI/HD SDI/SD SDI, character signal selectable
REFERENCE IN/OUT	BNC type (2), loop-through output HD: SMPTE ST274, tri-level sync signal, 0.6 Vp-p, 75 ohms SD: Black burst (NTSC: 0.286 Vp-p, 75 ohms/PAL: 0.3 Vp-p, 75 ohms) or NTSC 10F-BB

Input connectors	
AC IN	100 V to 240 V AC (1)
SDI RET 1 to 4	BNC type (4) 3G SDI: SMPTE ST424/425, 2.970 Gbps/2.967 Gbps HD SDI: SMPTE ST292, 1.485 Gbps/1.4835 Gbps SD SDI: SMPTE 259M, 270 Mbps
PROMPTER 1 PROMPTER 2/ VBS-RET	BNC type (2), loop-through output during 1CH mode, terminated internally at 75 ohms during 2CH mode, analog signal, 1.0 Vp-p, 75 ohms

Output connectors	
AUDIO OUT CH1, CH2	XLR 3-pin, male (2), 0 dBu/−20 dBu/+4 dBu
CHARACTER/SYNC, AES/EBU	BNC type (1), VBS, 1 Vp-p, 75 ohms AES/EBU format VBS and AES/EBU selectable
SDI OUT 1 to 4	3G/HD/SD SDI OUTPUT BNC type (4) 3G SDI: SMPTE ST424/425 Level-A/B, 0.8 Vp-p, 75 ohms, 2.970 Gbps/2.967 Gbps HD SDI: SMPTE ST292, 0.8 Vp-p, 75 ohms, 1.485 Gbps/1.4835 Gbps SD SDI: SMPTE 259M, 0.8 Vp-p, 75 ohms, 270 Mbps 3G SDI/HD SDI/SD SDI, character signal selectable

UHD SDI A, B	12G/6G/3G/HD SDI OUTPUT BNC type (2) 12G SDI: SMPTE ST2082, 0.8 Vp-p, 75 ohms, 11.88 Gbps/11.868 Gbps 6G SDI: SMPTE ST2081, 0.8 Vp-p, 75 ohms, 5.940 Gbps/5.934 Gbps 3G SDI: SMPTE ST424/425 Level-A/B, 0.8 Vp-p, 75 ohms, 2.970 Gbps/2.967 Gbps HD SDI: SMPTE ST292, 0.8 Vp-p, 75 ohms, 1.485 Gbps/1.4835 Gbps
--------------	--

UHD SDI C, D	12G/6G/3G/HD SDI I/O BNC type (2) 12G SDI: SMPTE ST2082, 0.8 Vp-p, 75 ohms, 11.88 Gbps/11.868 Gbps 6G SDI: SMPTE ST2081, 0.8 Vp-p, 75 ohms, 5.940 Gbps/5.934 Gbps 3G SDI: SMPTE ST424/425 Level-A/B, 0.8 Vp-p, 75 ohms, 2.970 Gbps/2.967 Gbps HD SDI: SMPTE ST292, 0.8 Vp-p, 75 ohms, 1.485 Gbps/1.4835 Gbps
--------------	---

Supplied accessories	
Number plates (1 set)	
Before Using This Unit (1)	
Operating Instructions (CD-ROM) (1)	

Optional accessories	
HKCU-SFP50 ST 2110 Interface Kit	
HKCU-SM50 Single Mode Fiber Connector Kit	
HZCU-CNFG50 Config Control Software	
HZCU-SNMP50 SNMP Agent Software	
HZCU-UHD35 4K/HDR Processor Software	
United States and Canada: Power cord set (1-551-812-XX) Other areas: Power cord set (1-782-929-XX)	

United States and Canada: Plug holder B (2-990-242-01) Other areas: Plug holder C (3-613-640-01)	
CCA-5-3 Connection Cable (3 meters), CCA-5-10 Connection Cable (10 meters)	
RMM-301 Rack Mount Adaptor	
Service Manual	
Related devices	
HDC5000/5500 Color Camera	
RCP-3000/1000 series Remote Control Panel	
MSU-1000 series Master Setup Unit	

## HDCU3500

General	
Power requirements	100 V to 240 V AC, 50/60 Hz
Current consumption	4.5 A (max.)
Operating temperature	−10 °C to +40 °C (14 °F to 104 °F)
Storage temperature	−20 °C to +60 °C (−4 °F to +140 °F)
Mass	Approx. 6.3 kg (13 lb 14 oz)

### External dimensions (Unit: mm (inches))

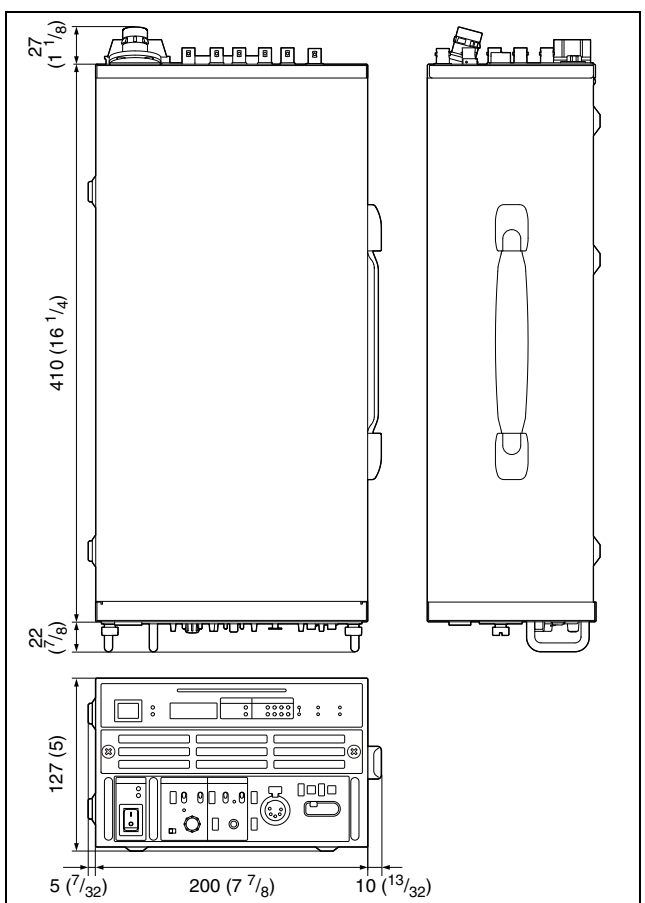

Input/output connectors	
CAMERA FIBER	Optical fiber connector (1)
INTERCOM/TALLY/IO PORT	D-Sub 50-pin connector (1) • INTERCOM (PROD/ENG), 4W: 0 dBu, RTS: 0 dBu, CC: −14 dBu • PGM, 3 systems, 0 dBu/−20 dBu • TALLY (R, G, Y) • FLAG
RCP/CNU	8-pin multi-connector (1)

TRUNK	12-pin (1)
LAN COM	8-pin (1)
NETWORK TRUNK	8-pin (1)
SDI I/O 1 to 4	3G/HD/SD SDI I/O BNC type (4) 3G SDI: SMPTE ST424/425 Level-A/B, 0.8 Vp-p, 75 ohms, 2.970 Gbps/2.967 Gbps HD SDI: SMPTE ST292, 0.8 Vp-p, 75 ohms, 1.485 Gbps/1.4835 Gbps SD SDI: SMPTE 259M, 0.8 Vp-p, 75 ohms, 270 Mbps 3G SDI/HD SDI/SD SDI, character signal selectable
REFERENCE IN/OUT	BNC type (2), loop-through output HD: SMPTE ST274, tri-level sync signal, 0.6 Vp-p, 75 ohms SD: Black burst (NTSC: 0.286 Vp-p, 75 ohms/PAL: 0.3 Vp-p, 75 ohms) or NTSC 10F-BB
<b>Input connectors</b>	
AC IN	100 V to 240 V AC (1)
SDI RET 1 to 4	BNC type (4) 3G SDI: SMPTE ST424/425, 2.970 Gbps/2.967 Gbps HD SDI: SMPTE ST292, 1.485 Gbps/1.4835 Gbps SD SDI: SMPTE 259M, 270 Mbps
PROMPTER 1 PROMPTER 2/ VBS-RET	BNC type (2), loop-through output during 1CH mode, terminated internally at 75 ohms during 2CH mode, analog signal, 1.0 Vp-p, 75 ohms
<b>Output connectors</b>	
AUDIO OUT CH1, CH2	XLR 3-pin, male (2), 0 dBu/-20 dBu/+4 dBu
CHARACTER / AES/EBU / SYNC	BNC type (1), VBS, 1 Vp-p, 75 ohms AES/EBU format VBS and AES/EBU selectable
SDI OUT 1 to 4	3G/HD/SD SDI OUTPUT BNC type (4) 3G SDI: SMPTE ST424/425 Level-A/B, 0.8 Vp-p, 75 ohms, 2.970 Gbps/2.967 Gbps HD SDI: SMPTE ST292, 0.8 Vp-p, 75 ohms, 1.485 Gbps/1.4835 Gbps SD SDI: SMPTE 259M, 0.8 Vp-p, 75 ohms, 270 Mbps 3G SDI/HD SDI/SD SDI, character signal selectable
UHD SDI A, B	12G/3G/HD SDI OUTPUT BNC type (2) 12G SDI: SMPTE ST2082, 0.8 Vp-p, 75 ohms, 11.88 Gbps/11.868 Gbps * 12G SDI can be selected by installing the HZCU-UHD35. 3G SDI: SMPTE ST424/425 Level-A/B, 0.8 Vp-p, 75 ohms, 2.970 Gbps/2.967 Gbps HD SDI: SMPTE ST292, 0.8 Vp-p, 75 ohms, 1.485 Gbps/1.4835 Gbps

UHD SDI C, D	12G/3G/HD SDI I/O BNC type (2) 12G SDI: SMPTE ST2082, 0.8 Vp-p, 75 ohms, 11.88 Gbps/11.868 Gbps * 12G SDI can be selected by installing the HZCU-UHD35. 3G SDI: SMPTE ST424/425 Level-A/B, 0.8 Vp-p, 75 ohms, 2.970 Gbps/2.967 Gbps HD SDI: SMPTE ST292, 0.8 Vp-p, 75 ohms, 1.485 Gbps/1.4835 Gbps
--------------	---

#### Supplied accessories

Number plates (1 set)

Before Using This Unit (1)

Operating Instructions (CD-ROM) (1)

#### Optional accessories

HKCU-SFP50 ST 2110 Interface Kit

HKCU-SM50 Single Mode Fiber Connector Kit

HKCU-FB50 UHB Transmission Board Kit

HZCU-CNFG50 Config Control Software

HZCU-SNMP50 SNMP Agent Software

HZCU-UHD35 4K/HDR Processor Software

United States and Canada: Power cord set (1-551-812-XX)

Other areas: Power cord set (1-782-929-XX)

United States and Canada: Plug holder B (2-990-242-01)

Other areas: Plug holder C (3-613-640-01)

CCA-5-3 Connection Cable (3 meters), CCA-5-10 Connection Cable (10 meters)

RMM-301 Rack Mount Adaptor

Service Manual

#### Related devices

HDC3500 Color Camera

HDC3100 Fiber Color Camera

HDC2000 HD Color Camera

HDC2580/2500/2400/1700 HD Color Camera

RCP-3000/1000 series Remote Control Panel

MSU-1000 series Master Setup Unit

## HKCU-FB50

#### General

Power consumption 40 W

Operating temperature -10 °C to +40 °C (14 °F to 104 °F)

Storage temperature -20 °C to +60 °C (-4 °F to +140 °F)

Dimensions (w/h/d, excluding protrusions) 310 × 112 × 39 mm (12 1/4 × 4 1/2 × 1 9/16 inches)

Mass TX board: Approx. 0.6 kg (1 lb 5.2 oz)

#### Input/output connectors

Connectors BNC

Number of lines 4

Signal type SMPTE ST2082/ST2081/ST425/ST424/ST292

#### Supplied accessories

UHB label (2)

Operating Instructions (1)



## HKCU-SDI50

General	
Power consumption	5 W
Operating temperature	5 °C to 40 °C (41 °F to 104 °F)
Storage temperature	-20 °C to +60 °C (-4 °F to 140 °F)
Dimensions (w/h/d, excluding protrusions)	21 × 57 × 230 mm ( $2^{27}/32 \times 2^{1/4} \times 9^{1/8}$ inches)
Mass	HIF board: Approx. 150 g (5.3 oz)
Output connectors	
HIF board: BNC type (4)	
12G-SDI: SMPTE ST2082, 0.8 Vp-p, 75 ohms, 11.880 Gbps/11.868 Gbps	
6G SDI: SMPTE ST2081, 0.8 Vp-p, 75 ohms, 5.940 Gbps/5.934 Gbps	
3G SDI: SMPTE ST424/425 Level-A/B, 0.8 Vp-p, 75 ohms, 2.970 Gbps/2.967 Gbps	
HD SDI: SMPTE ST292, 0.8 Vp-p, 75 ohms, 1.485 Gbps/1.4835 Gbps	
Supplied accessories	
30-pin cable (2)	
Screws +2.6x5 (4)	
Operating Instructions (1)	

## HKCU-SFP50

General	
Power consumption	43 W
Operating temperature	-10 °C to +40 °C (14 °F to 104 °F)
Storage temperature	-20 °C to +60 °C (-4 °F to +140 °F)
Dimensions (w/h/d, excluding protrusions)	258 × 116 × 41 mm ( $10^{1/4} \times 4^{5/8} \times 1^{5/8}$ inches)
Mass	Approx. 0.5 kg (1 lb 1.6 oz)
I/O connectors	
Connectors	SFP+, SFP28
Number of lines	2
Signal type	10GBASE-**, 25GBase-** (depending on SFP+/SFP28 transceiver module)  For information about the supported SFP+ and SFP28 transceiver modules (e.g. OTM-10GSR1), contact your Sony sales or service representative.
Supplied accessories	
Air divider plate (1)	
Rivet (3)	
60-pin harness (2)	
20-pin harness (1)	
Power supply harness (1)	
Screws M3x8 (6)	
Screws M2.6x5 (2)	
Bracket (1)	
Cover sheet (2)	
Operating Instructions (1)	

## HKCU-SM50

General	
Power consumption	1.2 W
Operating temperature	-10 °C to +40 °C (14 °F to 104 °F)
Storage temperature	-20 °C to +60 °C (-4 °F to +140 °F)
Dimensions (w/h/d, excluding protrusions)	66 × 67 × 30 mm ( $2^{5/8} \times 2^{3/4} \times 1^{3/16}$ inches)
Mass	Approx. 0.1 kg (3.5 oz)
Input/output connectors	
ST connectors for single-mode fiber cables (2)	
Supplied accessories	
SC-LC optical fiber cable (1)	
Optical module (1)	
Screws M3x8 (1)	
Bracket (1)	
Cover sheet (1)	
Operating Instructions (1)	

Design and specifications are subject to change without notice.

### Notes

- Always verify that the unit is operating properly before use. SONY WILL NOT BE LIABLE FOR DAMAGES OF ANY KIND INCLUDING, BUT NOT LIMITED TO, COMPENSATION OR REIMBURSEMENT ON ACCOUNT OF THE LOSS OF PRESENT OR PROSPECTIVE PROFITS DUE TO FAILURE OF THIS UNIT, EITHER DURING THE WARRANTY PERIOD OR AFTER EXPIRATION OF THE WARRANTY, OR FOR ANY OTHER REASON WHATSOEVER.
- SONY WILL NOT BE LIABLE FOR CLAIMS OF ANY KIND MADE BY USERS OF THIS UNIT OR MADE BY THIRD PARTIES.
- SONY WILL NOT BE LIABLE FOR THE TERMINATION OR DISCONTINUATION OF ANY SERVICES RELATED TO THIS UNIT THAT MAY RESULT DUE TO CIRCUMSTANCES OF ANY KIND.

SONY WILL NOT BE LIABLE FOR DAMAGES OF ANY KIND RESULTING FROM A FAILURE TO IMPLEMENT PROPER SECURITY MEASURES ON TRANSMISSION DEVICES, UNAVOIDABLE DATA LEAKS RESULTING FROM TRANSMISSION SPECIFICATIONS, OR SECURITY PROBLEMS OF ANY KIND.

Depending on the operating environment, unauthorized third parties on the network may be able to access the unit. When connecting the unit to the network, be sure to confirm that the network is protected securely.

### Open Source Software Licenses

On the basis of license contracts between Sony and the software copyright holders, this product uses open software. To meet the requirements of the software copyright holders, Sony is obligated to inform you of the content of these licenses.

For the content of these licenses, see the PDF file in the "License" folder of the supplied CD-ROM.