

SONY®

HD COLOR CAMERA

HSC-300

Power HAD FX



OPERATION MANUAL
1st Edition (Revised 1)

English

Before operating the unit, please read this manual thoroughly and retain it for future reference.

WARNING

To reduce the risk of fire or electric shock, do not expose this apparatus to rain or moisture.

To avoid electrical shock, do not open the cabinet. Refer servicing to qualified personnel only.

For the customers in the U.S.A.

This equipment has been tested and found to comply with the limits for a Class A digital device, pursuant to Part 15 of the FCC Rules. These limits are designed to provide reasonable protection against harmful interference when the equipment is operated in a commercial environment. This equipment generates, uses, and can radiate radio frequency energy and, if not installed and used in accordance with the instruction manual, may cause harmful interference to radio communications. Operation of this equipment in a residential area is likely to cause harmful interference in which case the user will be required to correct the interference at his own expense.

You are cautioned that any changes or modifications not expressly approved in this manual could void your authority to operate this equipment.

All interface cables used to connect peripherals must be shielded in order to comply with the limits for a digital device pursuant to Subpart B of Part 15 of FCC Rules.

This device complies with Part 15 of the FCC Rules. Operation is subject to the following two conditions: (1) this device may not cause harmful interference, and (2) this device must accept any interference received, including interference that may cause undesired operation.

For the customers in Canada

This Class A digital apparatus complies with Canadian ICES-003.

For the customers in Europe

This product with the CE marking complies with both the EMC Directive and the Low Voltage Directive issued by the Commission of the European Community.

Compliance with these directives implies conformity to the following European standards:

- EN60950-1: Product Safety
- EN55103-1: Electromagnetic Interference (Emission)
- EN55103-2: Electromagnetic Susceptibility (Immunity)

This product is intended for use in the following

Electromagnetic Environments:

E1 (residential), E2 (commercial and light industrial), E3 (urban outdoors), E4 (controlled EMC environment, ex. TV studio).

The manufacturer of this product is Sony Corporation, 1-7-1 Konan, Minato-ku, Tokyo, Japan.

The Authorized Representative for EMC and product safety is Sony Deutschland GmbH, Hedelfinger Strasse 61, 70327 Stuttgart, Germany. For any service or guarantee matters

please refer to the addresses given in separate service or guarantee documents.

For the State of California, USA only

Perchlorate Material - special handling may apply, See www.dtsc.ca.gov/hazardouswaste/perchlorate

Perchlorate Material : Lithium battery contains perchlorate.

For the customers in Taiwan only



廢電池請回收

Table of Contents

Overview	4
Features	4
System Configuration	6
Standalone operation example	6
System operation example (two cameras with Camera Control Units)	7
Parts Identification	8
Front right	8
Front left	9
Rear	9
Operation panel	10
Connector panel	11
Installation	12
Connecting a Camera Control Unit (CCU)	12
Attaching a Lens	13
Attaching a Viewfinder	13
Attaching a Microphone	14
Mounting the Camera to a Tripod	15
Adjusting the Shoulder Pad Position	16
Preparatory Settings.....	16
Adjusting the Black Balance and White Balance	16
Setting the Electronic Shutter	17
Setting the Local Time	18
Adjusting the Flange Focal Length	19
Setting the Focus Assist Function	19
Setting the Camera Outputs	21
Outputting a Trunk Signal	22
Menus.....	22
Displaying Menu Pages	22
Setting the Menu	23
Editing the USER Menu	24
OPERATION Menu	27
PAINT Menu	30
MAINTENANCE Menu	33
FILE Menu	35
DIAGNOSIS Menu	37
Appendices.....	37
Precautions	37
Error Messages	39
Using a “Memory Stick”	39
Specifications	40
Menu Tree	42

Overview

The HSC-300 is a 2/3-type high-definition portable video camera equipped with CCD units for 2,200,000 pixels, which can be used as a standalone camera as well as in a multi-camera studio system in combination with the HSCU-300 or HXCU-100¹⁾ Camera Control Unit and a master setup unit (MSU).

The camera incorporates the latest image capturing device and digital signal-processing LSI, and it performs newly developed digital transmission with the camera control unit (CCU), thus yielding high picture quality and high stability in image creation in addition to superior camera functions and operability.

1) An HSC-300 and HXCU-100 can be connected if both units are of version 1.10 or later.

Features

High picture quality and high performance

The latest 2/3-type Progressive IT CCD units for 2,200,000 pixel achieve high sensitivity and low smear. In addition, the 14-bit A/D converter and an original developed signal-processing LSI provide high picture quality of optimal grade.

Multiple formats

The camera covers 1080/59.94i, 720/59.94P, 1080/50i, and 720/50P.

With its wide-range down-converter, the camera also enables output of high-quality SD signals (525i/625i) from the camera and the connected CCU, establishing an optimum camera system for SD-system operations.

Newly designed integrated unit with low center of gravity

The camera has stylish appearance with low-slung design. When used in combination with the HDLA1500-series large-lens adaptor, it permits a viewfinder to be mounted at a low position, making the viewfinder position closer to the optical axis of the lens.

Optimized handle shape and VF slide mechanism for stable shooting

A new handle design has been adopted. A slight protrusion of the upper front part of the handle enables stable holding of the camera while you are shooting, by holding the front part of the handle. Furthermore, a slide mechanism is located at the viewfinder attachment position. Any difference in weight balance caused by having a different lens attached can be counteracted by adjusting the viewfinder attachment position, in combination with the movable shoulder pad position. This provides the best balance for shooting with the camera on your shoulder.

Operable in an HDLA large-lens adaptor

The camera can be mounted in an HDLA1500-series large-lens adaptor. Featuring the characteristics of requiring no cable connection and no adjustments, switching between large-lens studio operation and portable operation can be easily performed, enabling flexible application with high mobility.

ND/CC dual optical servo filters mounted

The camera incorporates ND and CC optical servo filter units, four each, which can be remotely controlled from an external control device, such as a remote control panel (RCP) or a master setup unit (MSU).

Position-adjustable shoulder pad

The position of the shoulder pad can be adjusted for stable shooting according to the build of the camera operator, the type of lens in use, or the shooting style.

A low-repulsion shoulder pad (position fixed) is available as an option. (Part No.: A-8286-346-A)

Function-assignable switches

The camera has buttons to which various functions can be assigned on the side panel and the rear. You can activate your desired function, such as electronic color-temperature conversion, instantly when shooting by assigning it to one of these buttons in advance.

Buttons on the handle are also available as function assignable switches.

Auto Lens Aberration Compensation function

The Auto Lens Aberration Compensation function (ALAC) is provided with this camera. This automatically reduces chromatic aberration of magnification when a lens that supports auto aberration compensation is attached.

For details on lenses supporting auto aberration compensation, contact a Sony sales representative or Sony service representative.

Focus assist functions

The VF detail function and focus assist indicator function facilitate focusing.

VF detail

Various functions are provided for the VF detail signal, which can be added only on images on the viewfinder screen in order to facilitate focusing in various situations: Functions for coloring the VF detail signal, flickering the VF detail signal by adding modulation, thickening the VF detail signal, and automatically compensating the VF detail level according to the zoom position.

Focus Assist Indicator

The focusing level indicator on the viewfinder screen provides a guide for focusing. The best focus setting can be easily determined by observing fluctuation of the level indicator as a guide.

“Memory Stick”¹⁾ operation

The camera is equipped with a “Memory Stick” port, which enables setup data storage and software upgrading using a “Memory Stick.”

1) “Memory Stick” and  MEMORY STICK™ are trademarks of Sony Corporation.

Various color-reproduction functions

Selection of multiple gamma tables

Seven types of standard and 4 types of hyper gamma tables are provided with this camera. The hyper gamma values enable cinematic image creations with wide dynamic range, which are different from those achieved with conventional video gamma.

Multimatrix color correction

In addition to the standard 6-axis matrix function, the camera has a multimatrix function that permits you to adjust the hue and chroma for color components in 16-axis directions independently. This is quite useful in color matching among multiple cameras.

Knee saturation

Change of hue and decrease in chroma that occur in highlighted areas can be compensated. This enables reproduction of natural skin tones under strong lighting.

Low key saturation

Hue and chroma in low-key zones can be compensated. Thus, compensation for color reproduction in all zones is enabled in combination with matrix color compensation and knee saturation functions.

Versatile detail control functions

Skin-tone detail function

This function allows control (emphasis or suppression) of the detail level for just a certain hue or chroma area in the image, by creating a detail gate signal from color components of your specified hue, such as skin tones.

Detail boost-frequency control

The boost frequency can be adjusted from 20 to 30 MHz. This allows the detail thickness to be set appropriately for the subject, thus enabling more subtle image expression.

H/V ratio control

The ratio between horizontal and vertical detail can be adjusted.

White/black limiter

The white and black details can be limited independently.

Easy menu-based setting

Selections and settings for viewfinder display items, safety-zone marker¹⁾ or center marker,²⁾ screen size marker, etc. can be made quickly and easily, using setup menus displayed on the viewfinder screen or an external monitor.

- 1) Safety zone marker: A box-shaped marker displayed on the viewfinder screen which indicates 80%, 90%, 92.5%, or 95% of the total screen area
- 2) Center marker: A cross-shaped marker which indicates the center of the viewfinder screen

Wide variety of viewfinder display options

Along with items such as operation messages, a zebra pattern,¹⁾ a safety-zone marker, and a center marker, camera settings may also be displayed on the viewfinder screen. Furthermore, there are various cautionary and warning indications to be occasionally displayed, making it simple to check the status of the camera.

- 1) Zebra pattern: A stripe pattern displayed on the viewfinder screen which indicates the portions where the video level is above about 70% or 100%. Used to check the video level of the subject.

Digital triax transmission

The camera uses an industry standard dual-shield coaxial (triax) camera cable for connection between the camera and a CCU. Newly developed original digital transmission technology is built into the camera, and high-quality pictures can be transmitted between the camera and CCU, regardless of the cable length.

Versatile choices of viewfinders

Multiformat monochrome CRT viewfinders, HDVF-200 (2-type) and HDVF-550 (5-type) can be selected for use in studio and portable systems.

Color LCD viewfinders, HDVF-C35W (3.5-type), HDVF-C550W (5-type), and HDVF-C730W (6.5-type), are also selectable to cover various applications.

Prevention of electrical shock

When the power connection is unsafe, the power supply from the connected Camera Control Unit will be shut off.

System Configuration

Peripherals and related devices for the camera are shown in figures.

Note

Production of some of the peripherals and related devices shown in the figures has been discontinued. For advice on choosing devices, please contact your Sony dealer or a Sony sales representative.

Standalone operation example

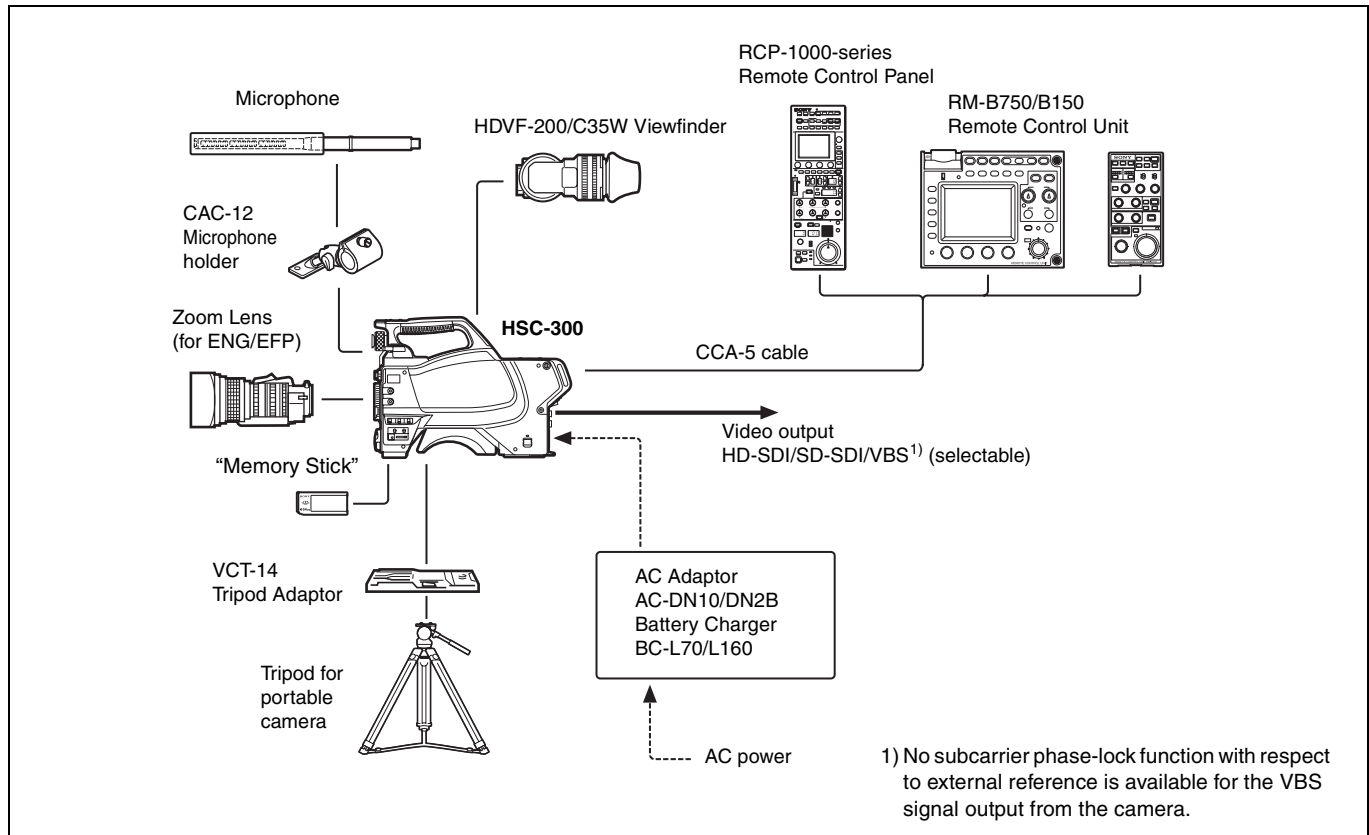

System operation example (two cameras with Camera Control Units ^{a)})

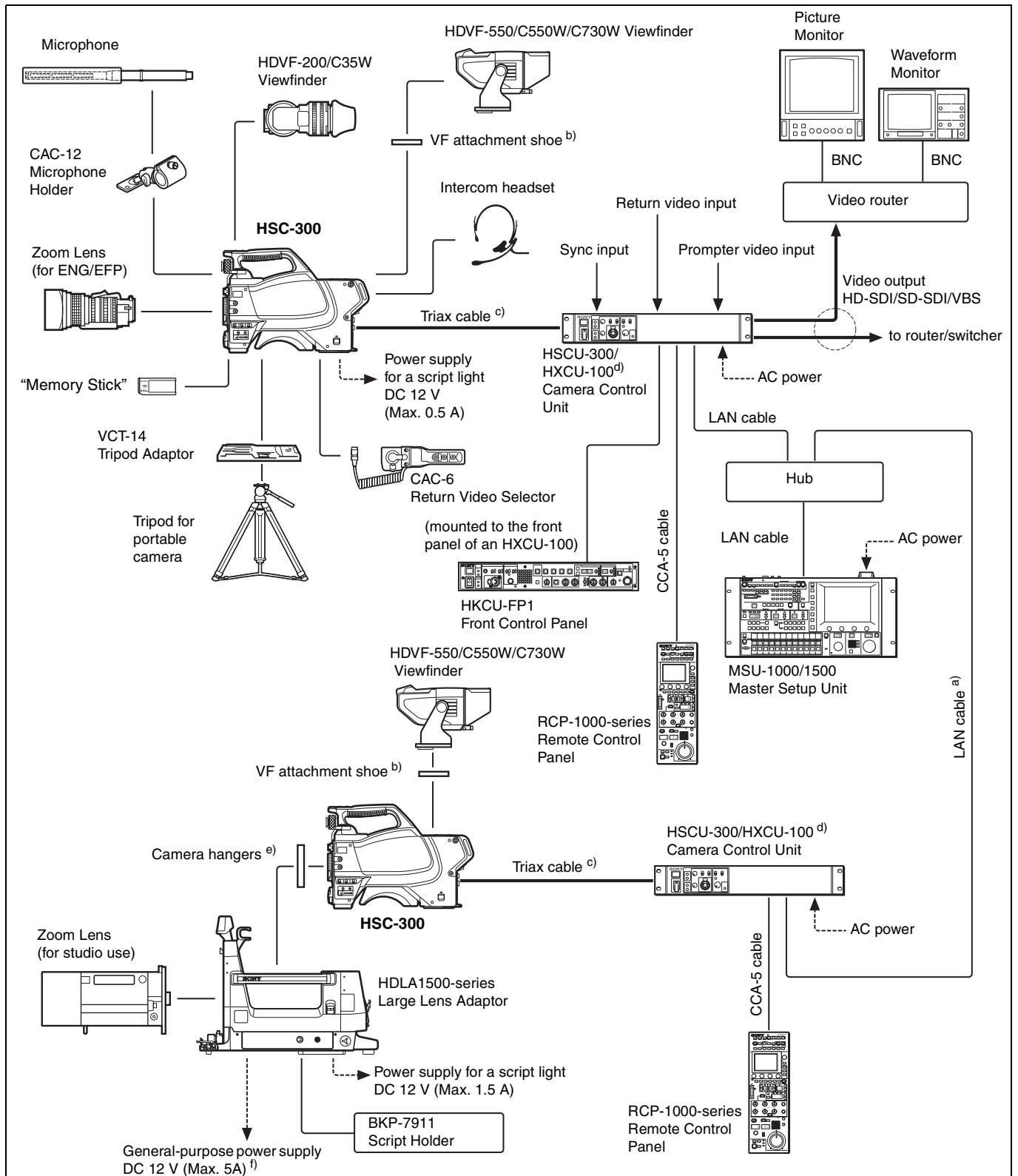

a) Enabled only when an HSCU-300 is connected.

b) Supplied with the HDVF-550/C550W/C730W, Part No.: A-7612-405-E

c) 900 m (2953 ft) when an HSCU-300 is connected or 600 m (1969 ft) when an HXCU-100 is connected at maximum and 50 m (164 ft) at minimum when using Fujikura 8.5-mm dia. cables.

For information of other cables, see "About the distances of triax transmission (when an HSCU-300 is connected)" (page 38) or "About the distances of triax transmission (when an HXCU-100 is connected)" (page 38).

d) An HSCU-300 and HXCU-100 can be connected if both units are of version 1.10 or later.

e) Supplied with the HDLA1500/1505, Part No.: A-1128-405-A

f) For general-purpose DC 12 V output, the serial number must be the following or higher:

HDLA1500: 13001 or 43001, HDLA1503: 52001,
 HDLA1505: 11001 or 41001 or 401001, HDLA1507: 401001

Parts Identification

Front right

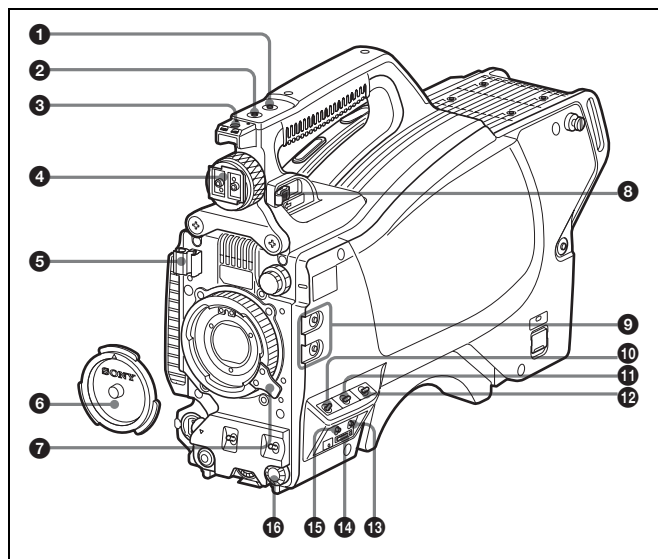

1 INCOM (intercom) button (UC model)/ENG (engineer line) button (CE model)

UC model: The intercom microphone is on while this button is held pressed.

CE model: The intercom microphone is on and the engineer line is selected while this button is held pressed.

You can also assign other functions with a menu operation.

2 RET 1 (return video 1) button

The return video 1 signal from the CCU is monitored on the viewfinder screen while this button is held pressed. It functions the same as the RET 1 button on the operation panel (page 10) on the rear of the camera.

You can also assign other functions with a menu operation.

3 Accessory shoe

To attach an accessory using a 1/4-inch screw.

4 Viewfinder shoe

Mount a viewfinder.

For details, see "Attaching a Viewfinder" (page 13).

5 Lens cable clamp

To secure the cable of the lens (optional).

6 Lens mount cap

The cap can be removed by moving the lens fixing lever upward. Always keep the lens mount covered with this cap when a lens is not attached.

7 Lens fixing lever

Move the lever down to secure the lens in the lens mount.

For details, see "Attaching a Lens" (page 13).

8 Viewfinder front-rear position lock lever

The viewfinder position can be adjusted forward or backward when the lock is released by the lever.

For details on the adjustment, see "To adjust the viewfinder's front-rear position" (page 13).

9 Assignable buttons

You can assign a function to the upper button by using ASSIGNABLE 1 and the lower button with ASSIGNABLE 2 on the <SWITCH ASSIGN1> page of the OPERATION menu.

10 GAIN switch

To select the gain of the video amplifier based on lighting conditions when the camera is used in standalone status without connecting a CCU.

When shipped from the factory, the values set are L = 0 dB, M = 6 dB, and H = 12 dB.

11 AUTO KNEE and output signal selection switch

To select the signal (color-bar signal or camera's video signal) to be used as output to a VTR, the viewfinder, or a video monitor when the camera is used in standalone status without connecting a CCU.

When the camera's video signal is being used as output, the auto knee function can be selected.

BARS/OFF: Output is a color-bar signal.

CAM/OFF: Output is the camera's video signal. The auto knee circuit is disabled.

CAM/ON: Output is the camera's video signal. The auto knee circuit is enabled.

12 WHITE BAL (white balance memory selection) switch

To select the white balance adjustment method or the memory used to store the adjusted value when the camera is used in standalone status without connecting a CCU.

PRST (preset): White balance is adjusted to a preset value corresponding to a color temperature of 3200K.

A: To select memory A.

B: To select memory B.

Note

When a CCU or an external control device, such as an RCP/RM or MSU, is connected, the functions of 10 to 12 are controlled from the external device, and the controls on the camera are disabled.

13 DISPLAY/MENU switch

Select the display on the viewfinder screen.

DISPLAY: To display various textual information and markers, such as messages showing the camera settings and operating status, the center marker, and the safety zone marker, in addition to camera images.

OFF: To not display textual information and markers.

MENU: To display menus for camera settings, in addition to camera images.

The switch functions the same as the DISPLAY/MENU switch on the rear operation panel.

14 "Memory Stick" slot and access lamp

When you insert a "Memory Stick" into the slot, the access lamp lights in green.

The lamp is lit in red while writing/reading data to/from the "Memory Stick."

Note

When the access lamp is lit in red, do not insert/remove the "Memory Stick" or turn off the camera.

15 STATUS/CANCEL switch

STATUS: To display status information of this camera in the viewfinder when no menu is displayed with the DISPLAY/MENU switch set to DISPLAY.

CANCEL: To cancel changed settings or return the display to the previous menu when a menu is displayed in the viewfinder.

16 Menu control knob (rotary encoder)

Used to select settings from menus displayed on the viewfinder screen (by rotating it) and to confirm settings (by pushing it).

This knob functions the same as that on the rear operation panel.

Front left

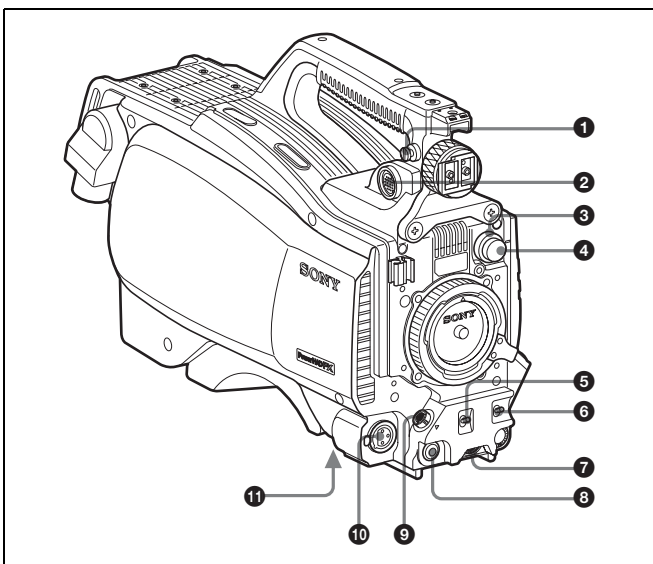

1 Shoulder strap fitting post

Attach one end of a shoulder strap (optional, part No. A-6772-374-C) to this fitting post and the other end to the fitting post on the other side of the camera.

2 VF (viewfinder) connector (20-pin)

Connect the cable of the viewfinder (optional).

3 CC filter select knob

To select the built-in CC filters (A: cross, B: 3200K, C: 4300K, D: 6300K).

4 ND filter select knob

To select the built-in ND filters (1: clear, 2: 1/4 ND, 3: 1/16 ND, 4: 1/64 ND).

5 SHUTTER switch

When the camera is used in standalone status without connecting a CCU, use this switch to turn ON or OFF the electronic shutter and change (SEL) the shutter speed and shutter mode.

For details, see "Setting the Electronic Shutter" (page 17).

6 AUTO W/B BAL (white and black balance automatic adjustment) switch

To automatically adjust white and black balance when the camera is used in stand-alone status without connecting to a CCU.

WHT: To automatically adjust white balance.

BLK: To automatically adjust black balance.

For details, see "Adjusting the Black Balance and White Balance" (page 16).

7 INTERCOM LEVEL control

To adjust the intercom/earphone volume level.

The intercom level adjustment is enabled when the LEVEL/MIC switch on the UC-type operation panel (page 10) or the LEVEL switch on the CE-type operation panel (page 10) on the rear is set to "FRONT."

8 RET (return video) button

When this button is pressed, the picture on the viewfinder changes to the return video signal selected with the RET 2/3/4 select switch (page 10) on the operation panel on the rear of the camera.

You can also assign other functions with a menu operation.

9 LENS connector (12-pin)

Connect the lens cable. The camera can control the lens functions through this cable.

10 MIC 1 IN (microphone 1 input) connector (XLR 3-pin)

Connect a microphone.

This connector and the AUDIO IN CH1 connector are alternately activated with the MIC 1 select switch on the rear connector panel.

11 Tripod mount (bottom)

Attach the VCT-14 Tripod Adaptor when mounting the camera on a tripod.

For details, see "Mounting the Camera to a Tripod" (page 15).

Rear

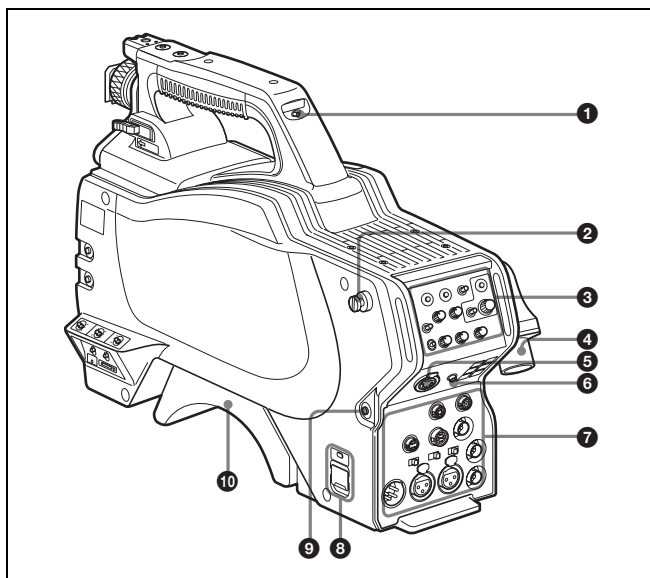

1 Tally lamp and switch

ON: The tally lamp lights when a tally signal is input to the connected CCU or a call signal is generated in response to pressing of a CALL button.

OFF: The tally lamp is prevented from lighting.

2 Shoulder strap fitting post

3 Operation panel (See "Operation panel".)

4 Camera Control Unit (CCU) connector (triax connector)

Connect an HSCU-300 or HXCU-100 Camera Control Unit using a triax cable.

5 INTERCOM connector (XLR 5-pin)

Connect an XLR 5-pin headset for input and output of intercom audio signals.

The connector can be used for communication over the engineer line when the camera is in standby status.

6 EARPHONE jack (stereo minijack)

For connecting an earphone for output of the intercom audio.

7 Connector panel (See "Connector panel" on page 11.)

8 CAMERA POWER switch and indicator

CCU: To operate on power supply via the connected CCU.

EXT: To operate on power supply through the DC IN connector.

The indicator is lit in green during operation. It is lit in red while standby power is being supplied from the CCU, even if the switch is set to OFF.

Note

When a CCU is connected, external power supply (EXT) cannot be used.

9 CALL button

When you press this button, the red tally lamp of the connected external control device (RCP/RM, MSU, etc.) will light. Use to call the operator of the external control device.

10 Shoulder pad

You can adjust the position on your shoulder.

For details, see "Adjusting the Shoulder Pad Position" (page 16).

Operation panel

UC type: Model for NTSC areas

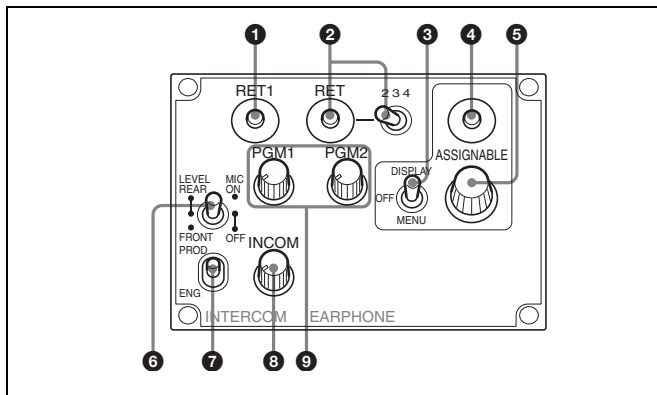

1 RET 1 (return video 1) button

The return video signal is displayed on the viewfinder screen while the button is held pressed.

2 RET (return video) button and 2/3/4 (return video 2/3/4) select switch

When other return video systems are used in addition to return video 1, the signal selected with the 2/3/4 switch is displayed on the viewfinder screen while holding the RET button pressed.

Note

The RET 1 button has priority over the RET (2/3/4) button if both buttons are pressed.

3 DISPLAY/MENU switch

This switch functions the same as the DISPLAY/MENU switch on the front (page 8).

4 ASSIGNABLE button

You can assign a function with ASSIGNABLE REAR on the <SWITCH ASSIGN1> page of the OPERATION menu.

5 Menu control knob (rotary encoder)

This knob functions the same as the menu control knob on the front (page 9).

6 LEVEL/MIC (intercom level control/microphone) switch

To determine whether to use the INTERCOM LEVEL control (page 9) on the front and to turn the intercom headset microphone ON/OFF.

Switch position	INTERCOM LEVEL control on the front	Headset microphone
REAR/ON	Inactive	ON
REAR/OFF		OFF
FRONT/OFF	Active	

7 Line select switch

To select the intercom line:

PROD: Producer line

ENG: Engineer line

8 INCOM (intercom) level control

To adjust the intercom audio listening level.

9 PGM1 (program 1) and PGM2 (program 2) controls

To adjust the audio listening level of program 1 or program 2, respectively.

CE type: Models for PAL areas

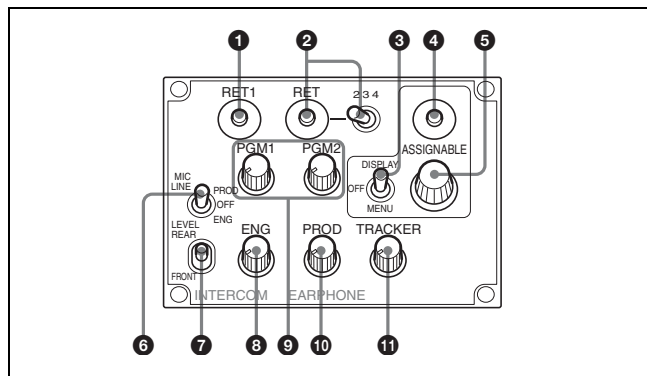

1 to 5 are the same as those of the UC type.

6 MIC LINE (intercom microphone line) switch

To select the talk line for intercom:

PROD: To talk over the producer line

OFF: To turn off the headset microphone for the intercom line

ENG: To talk over the engineer line

7 LEVEL switch

REAR: The intercom audio listening level is adjusted with the ENG or PROD control on this panel.

FRONT: The levels adjusted on the rear panel can be totally adjusted with the INTERCOM LEVEL control on the front.

8 ENG (engineer line) control

To adjust the intercom audio listening level of the engineer line.

9 PGM1 (program 1) and PGM2 (program 2) controls

To adjust the audio listening level of program 1 or program 2, respectively.

10 PROD (producer line) control

To adjust the intercom audio listening level of the producer line.

11 TRACKER control

To adjust the intercom audio listening level at the TRACKER connector on the connector panel.

Connector panel

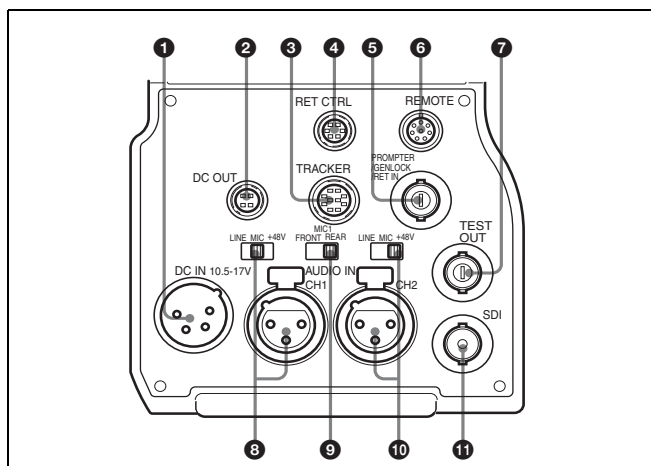

1 DC IN (DC power supply input) connector (XLR 4-pin)
For connection to an AC-DN10 AC Adaptor, etc. to supply power to the camera. (When a CCU is connected, this connector cannot be used.)

2 DC OUT (DC power supply output) connector (4-pin)
To supply power to a script light or equivalent (12 V DC, max. 0.5 A).

3 TRACKER connector (10-pin)
For external interfaces, such as intercom and tally.

4 RET CTRL (return control) connector (6-pin)
For connection to a CAC-6 Return Video Selector.

5 PROMPTER/GENLOCK/RET IN (prompter signal output/external sync signal input/VBS return input) connector (BNC type)

- When a CCU is connected, this connector outputs a VBS prompter 1 signal.
- When the camera is used in standalone status without connecting a CCU, use this connector for input of an external sync signal (BB or 3-level sync). If a VBS signal is input, you can check the input image by pressing the RET button.

Notes

- Even when a BB signal is used for the external sync signal, no subcarrier phase-lock function is available for the VBS output signal.

- As PROMPTER is set to PWR SAVE at the factory, a prompter signal is not output. Set it to ACTIVE on the POWER SAVE page of the MAINTENANCE menu.

6 REMOTE connector (8-pin)

For connection to an RM-B150/B750 Remote Control Unit, RCP-1000-series Remote Control Panel, or MSU-1000/1500 Master Setup Unit.

Note

When a CCU is used in combination, this connector functions as the trunk signal input/output. Do not connect any remote control device to this connector.

7 TEST OUT connector (BNC type)

To output an analog signal.
This supplies a VBS signal, a VBS prompter 2 signal (only when an HSCU-300 is connected), an HD-Y signal equal to the signal output from the VF connector, an HD-SYNC signal, or an SD-SYNC signal, depending on which of these you have selected on the menu.

Note

The VBS output signal has no subcarrier phase-lock function with respect to external sync signals.

8 AUDIO IN CH1 connector (XLR 3-pin) and input select switch

Connect a channel 1 audio signal and set the switch according to the connected source device.

LINE: When a line-level (0 dBu) signal source is connected

MIC: When an external microphone is connected

+48V: To supply power of +48 V to the connected external microphone

9 MIC 1 (microphone 1) select switch

Select the microphone for channel 1.

FRONT: To use the microphone connected to the MIC 1 IN connector

REAR: To use the microphone connected to the AUDIO IN CH1 connector

10 AUDIO IN CH2 connector (XLR 3-pin) and input select switch

Connect a channel-2 audio signal and set the switch according to the connected source device in the same manner as with channel 1.

11 SDI (serial digital interface) connector (BNC type)

For HD-SDI or SD-SDI signal output.

You can select from among camera line signal, return signal, VF signal, and SDI prompter signal (only when an HSCU-300 is connected) for the output with a menu operation.

Notes

- As SDI OUT is set to PWR SAVE at the factory, an SDI signal is not output. Set it to ACTIVE on the POWER SAVE page of the MAINTENANCE menu.
- Only a signal of the format selected on the CCU for the input signal can be output from the camera as the prompter signal.
The formats which can be selected on the CCU are of the following 4 types:

- Analog VBS × 2 channels
- SD-SDI × 1 channel
- HD-SDI × 1 channel
- VBS-Y only × 1 channel (LOW LATENCY)

Installation

Connecting a Camera Control Unit (CCU)

When operating the camera in a system with a CCU, connect between the CCU connector of the camera and the CAMERA connector of the CCU, using a triax cable.

When required, secure the cable, using the supplied cable clamp belt.

To use the cable clamp belt

- 1** Insert the belt bracket **C** into hole **A** or **B** of the cable clamp belt.

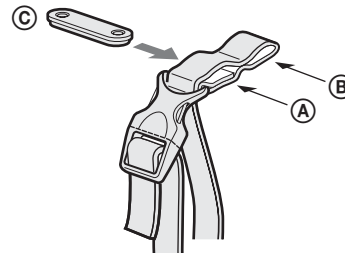

- 2** ① Remove the back screw-hole cover on the top of the camera and ② secure the cable clamp belt to the camera, using the two supplied screws (+B3×10).

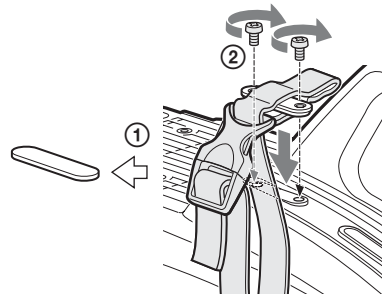

- 3** ① Release the buckle, ② bundle the cable with the belt, ③ then lock the buckle again.

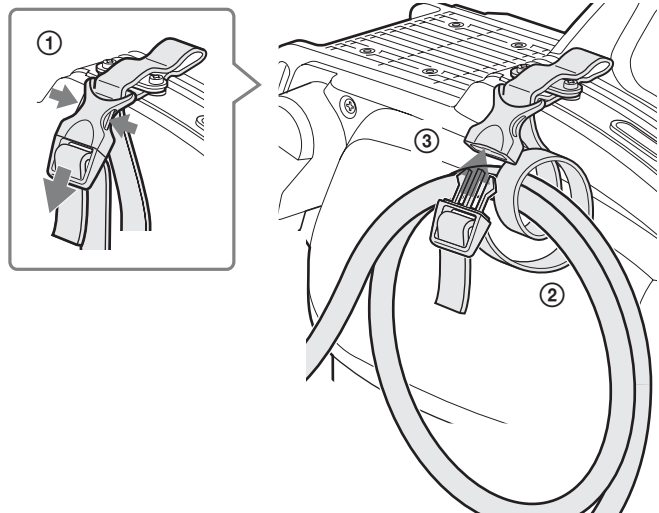

- 4** Adjust the length by pulling down the end of the belt.

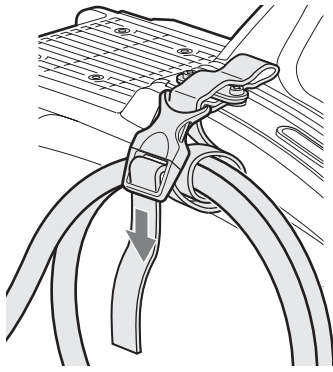

Attaching a Lens

For information on handling lenses, refer to the operation manual for the particular lens

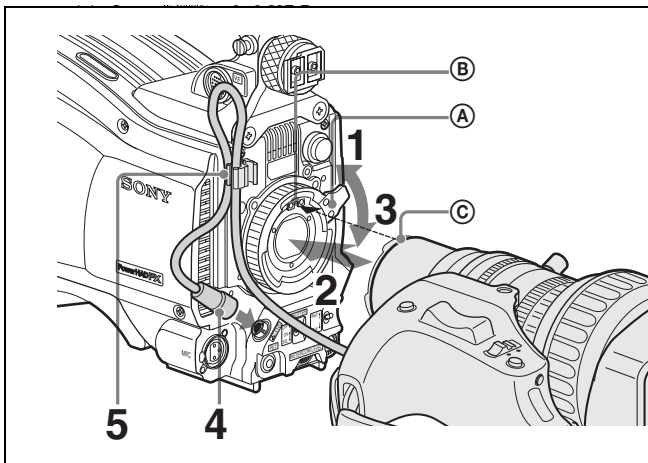

- 1** Push the lens fixing lever **A** upward and remove the lens mount cap from the lens mount.
- 2** Align the lens' alignment pin **C** with the notch **B** in the upper part of the lens mount and insert the lens into the mount.
- 3** While supporting the lens, push the lens fixing lever **A** downward to secure the lens.
- 4** Connect the lens cable to the LENS connector.
- 5** Secure the lens cable with the cable clamp.

To use a large studio-use lens

A large studio-use lens can be used with this camera by mounting the camera on an optional HDLA1500-series Large Lens Adaptor.

Note

When attaching the camera hangers to the camera, always use the screws (+B4×10) supplied with the lens adaptor.

For details, refer to the operation manual supplied with the HDLA1500-series adaptor.

Attaching a Viewfinder

Caution

When the viewfinder is attached, do not leave the camera with the eyepiece facing the sun. Direct sunlight can enter through the eyepiece, be focused in the viewfinder and cause fire.

Example: Attaching an HDVF-200 Viewfinder

For details on the viewfinder, refer to the operation manual for the viewfinder.

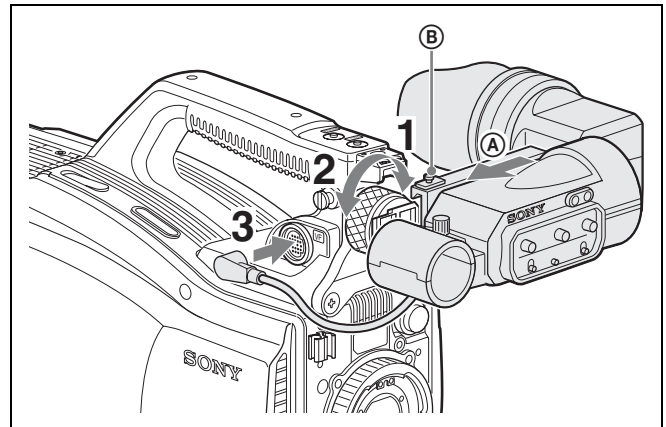

- 1** Loosen the viewfinder left-right positioning ring and slide the viewfinder in the direction of arrow **A**. The viewfinder stopper **B** automatically pops down.
- 2** Tighten the viewfinder left-right positioning ring to secure the viewfinder at the most convenient position.
- 3** Connect the viewfinder cable to the VF connector.

To adjust the viewfinder's front-rear position

The viewfinder can slide in the range of 53 mm (2 1/8 inches). Adjust the front-rear position so that you can easily operate it on your shoulder.

① Pulling the LOCK lever backward permits you to slide the viewfinder backward or forward. ② Adjust the viewfinder front-rear position and ③ lock it by returning the lever forward to the original position.

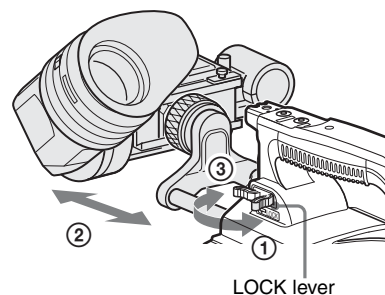

To detach the viewfinder

Loosen the viewfinder left-right positioning ring, pull the viewfinder stopper, then pull out the viewfinder by sliding it in the direction opposite to that when attached.

Status displays in the viewfinder

Besides the video image, the viewfinder can display characters and messages showing the camera settings and operation status, as well as items such as a center marker or safety-zone marker.

When the DISPLAY/MENU switch is set to DISPLAY

Items set to ON using the menu or related switches will be displayed.

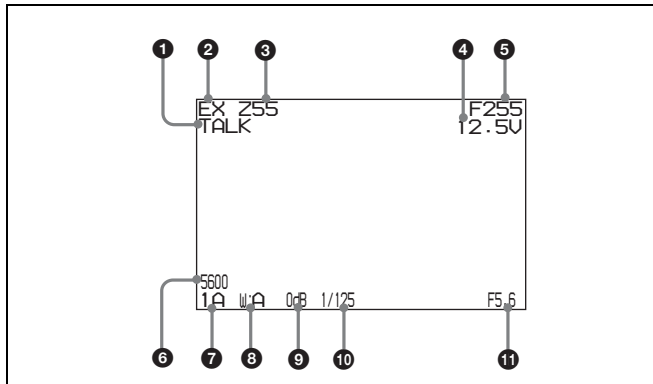

1 TALK indication

Displayed when the intercom microphone is set to ON.

2 EX (lens extender) indication

Displayed when a lens extender is in use.

3 Zoom position indication

Indicates the approximate position of the zoom lens variator between wide angle (0) and telephoto (99).

4 Battery voltage indication

When the CAMERA POWER switch is set to EXT, the DC IN voltage is displayed.

When the switch is set to CCU, the internal voltage of the camera is displayed.

5 Focus position indication

Shows the focus position of a zoom lens as a numeric value (0 to 255 [infinity]).

6 5600K mode indication

Displayed when the internal electrical filter (5600K) is set to ON.

7 Filter indication

Displays the types of filters currently selected. The number (1, 2, 3, or 4) indicates the ND filter, and the letter (A, B, C, or D) indicates the CC filter.

8 White balance memory indication

Shows the currently selected white balance automatic adjustment memory. This is not displayed when a CCU is connected.

W:A: The WHITE BAL switch is set to A.

W:B: The WHITE BAL switch is set to B.

W:P: The WHITE BAL switch is set to PRST.

9 Gain value indication

Shows the video gain value (dB) set with the GAIN switch.

10 Shutter/ECS indication

Displays the shutter/ECS status. Nothing is displayed if the electronic shutter is set to OFF.

11 F-value indication

Indicates the lens F (iris opening) value.

When the STATUS/CANCEL switch is set to STATUS

The status display is changed to show the following items:

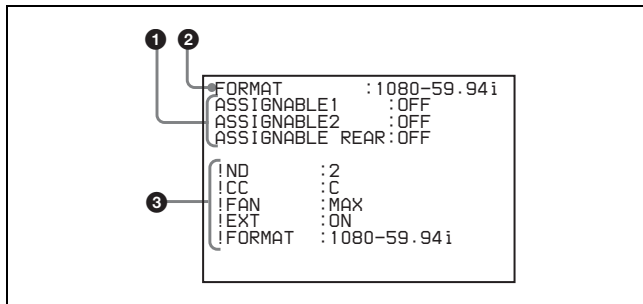

1 Assignable button indication

The functions assigned to the assignable buttons are indicated.

For the functions that can be assigned, see OPERATION menu <SWITCH ASSIGN1> (page 29).

2 Format indication

The current video format is displayed.

3 '! IND' indication area

This area is used to display abnormal statuses, using the '! IND' function. Display options can be set, using the menu.

For details, see OPERATION menu <! IND> (page 27).

Attaching a Microphone

A microphone can be attached to the camera, using the microphone holder of the viewfinder or an optional CAC-12 Microphone Holder.

For attaching to the microphone holder of the viewfinder, refer to the instruction manual for the viewfinder.

When the microphone is attached to the microphone holder of the viewfinder

Secure the microphone cable (A) to the cable clamp (B) of the camera.

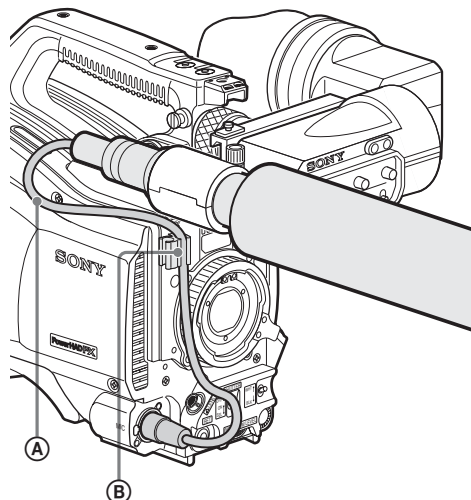

To attach a microphone, using a CAC-12

When attaching a long-type microphone, such as an ECM-674/678, use an optional CAC-12 Microphone Holder.

- 1 ① Remove the front screw-hole cover on the top then
② fix the CAC-12 in place with the two screws (+B4×8) supplied with the CAC-12.

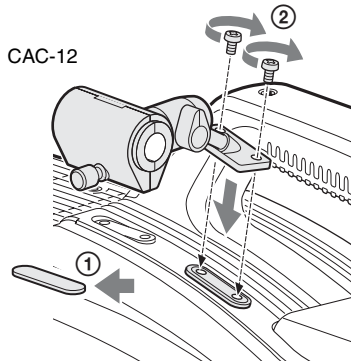

- 2 Loosen the screw to open the CAC-12 and attach the microphone.

If the microphone diameter is small, attach the adaptor (A) (supplied with the CAC-12 or the microphone) to the microphone.

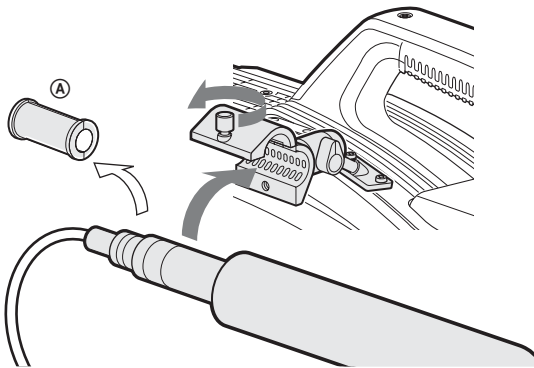

Mounting the Camera to a Tripod

Mount the camera to a tripod, using an optional VCT-14 Tripod Adaptor.

Caution

- Select an appropriate hole from among those at the bottom of the tripod adaptor considering the balance of the weight of the camera and the tripod adaptor. If an inappropriate hole is selected, the camera may fall over.
- Check that the size of the selected hole matches that of the screw of the tripod. If they do not match, the tripod adaptor cannot be attached to the tripod securely.

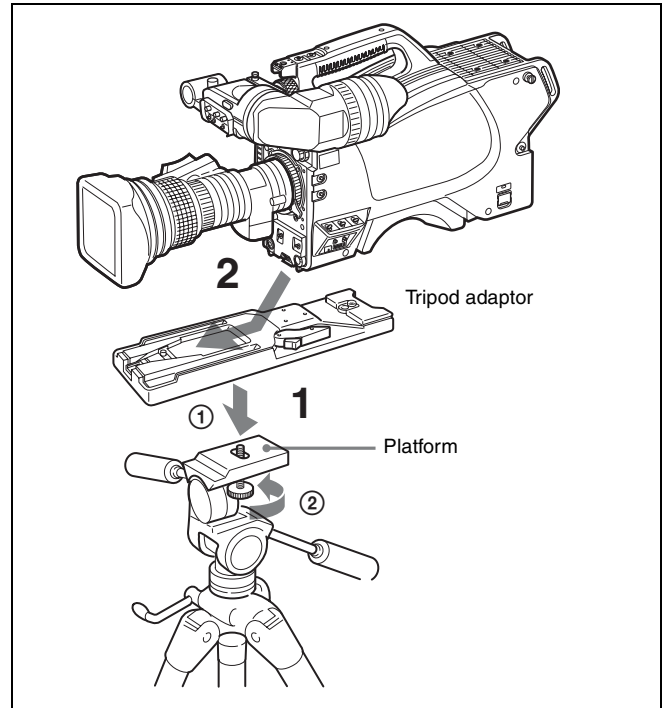

- 1 ① Attach the tripod adaptor to the tripod and ② secure it with the screw.
- 2 Place the camera on the tripod adaptor and slide forward it along the groove of the tripod adaptor until it clicks.

To remove the camera from the tripod adaptor

Hold down the red button and pull the lever in the direction of the arrow.

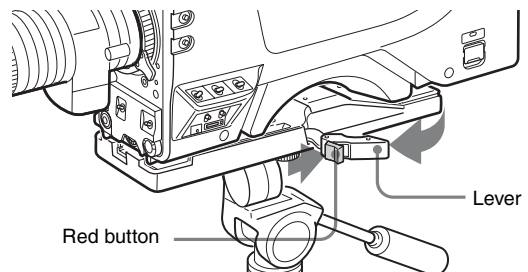

If the pin of the tripod adaptor does not return to its original position

After removing the camera, if the pin of the tripod adaptor does not return to its original position, hold down the red button and move the lever in the direction of the arrow to return the pin to its original position. It is not possible to mount a camera with the pin not seated.

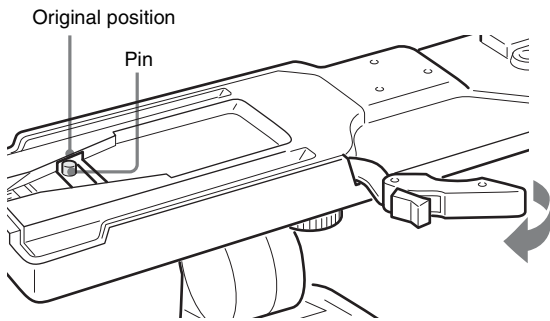

Adjusting the Shoulder Pad Position

You can shift the shoulder pad in the range of 28 mm (1 1/8 inches). This adjustment helps you get the best balance for shooting with the camera on your shoulder.

To adjust

① Raise the lever in the center of the shoulder pad to unlock the shoulder pad, ② slide the shoulder pad backward or forward until it is in the most convenient position, and ③ move the lever down to lock the shoulder pad in the selected position.

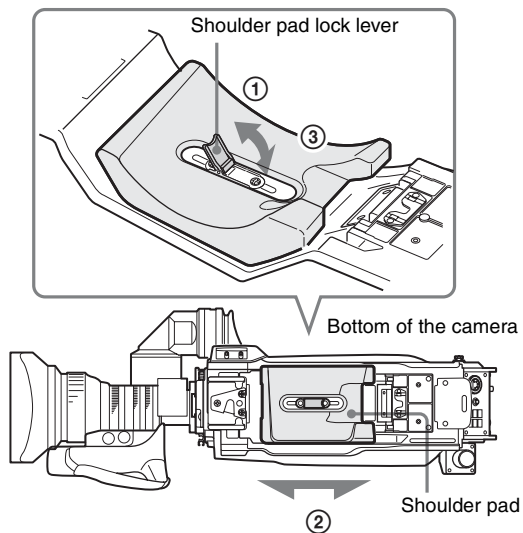

Preparatory Settings

Adjusting the Black Balance and White Balance

In order to maintain high picture quality when using the camera, it is necessary to set the black balance and white balance appropriately for the conditions.

Note

When a CCU or an external control device, such as an RCP/ RM or an MSU, is connected, the black balance and white balance are controlled from the external device, and adjustment on the camera is disabled.

Black balance adjustment

The black balance needs adjustment in situations like the following:

- The first time the camera is used
 - When the camera is used after a long period of disuse
 - When the surrounding temperature changes greatly
 - When the gain value is changed using the setup menus
- Normally, there is no need to adjust the black balance every time the camera is turned on.

White balance adjustment

Always adjust the white balance when lighting conditions change.

To adjust the black balance

Push the AUTO W/B BAL switch to BLK.

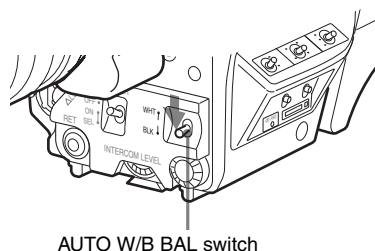

Automatic black balance adjustment begins.

In automatic adjustment of black balance, both the black set and black balance are adjusted.

During adjustment, the message "ABB: EXECUTING" will be displayed on the viewfinder screen.

When the adjustment process is completed, the message "ABB: OK" will be displayed.

The adjusted value is automatically stored in memory.

The black balance values stored in memory will be preserved even when the camera power is turned off.

Notes

- During black balance adjustment, the iris will be automatically closed.
- During black balance adjustment, the gain switching circuit will work automatically, and the viewfinder screen will flicker several times. This is not a malfunction.

To adjust the white balance

- 1 Select the built-in filters according to the lighting conditions with the filter select knobs.

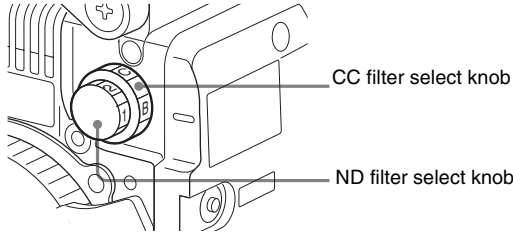

ND Filter		CC (color temperature conversion) filter	
1	Clear	A	Cross filter
2	1/4 ND	B	3200K (clear)
3	1/16 ND	C	4300K
4	1/64 ND	D	6300K

- 2 Place a white pattern, as shown below, with the same lighting conditions as the subject, and zoom in on it. A white object (white cloth, a white wall, etc.) near the subject may be used in place of a white pattern.

A rectangle centered in the screen:
The length of the sides must be at least 70% of the height and width of the screen.

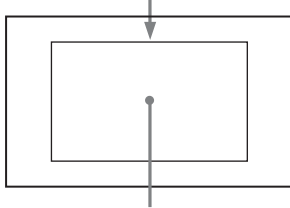

Within this rectangle, there must be an area of white greater than 10% of the entire screen.

Note

Be careful not to have any spots of high illumination in the rectangle.

- 3 Adjust the lens iris opening.
 - With a manually adjusted lens:** Set the opening to an appropriate value.
 - With a lens which has automatic iris control:** Set the lens' automatic/manual iris control switch to automatic.
- 4 Select white balance memory A or B with the WHITE BAL switch and push the AUTO W/B BAL switch toward WHT.

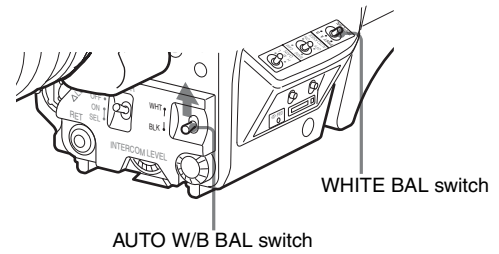

Automatic white balance adjustment begins. During adjustment, the message "AWB: EXECUTING" will be displayed on the viewfinder screen. After about one second, the message "AWB: OK" will be displayed, and the adjustment process will complete. The adjusted value will be automatically stored in the selected memory (A or B).

Note

When using a zoom lens with automatic iris control capability, hunting¹⁾ may occur. Adjust the lens' iris gain control (labeled IG, IS, S, etc.).

1) Hunting: The automatic iris responds over and over, and the image repeatedly darkens and lightens.

For more information, refer to the operation manual for the lens.

About white balance memory

There are two white balance memories: A and B. When you execute automatic white balance adjustment, the adjusted white balance value and the settings of the filter select knobs will be stored in either memory A or B, selected with the WHITE BAL switch. The white balance values stored in memory will be preserved even when power is turned off. When power is turned on again, the white balance in memory corresponding to the current WHITE BAL switch setting is retrieved. By setting FILTER WHT MEM to ON on the <OTHERS 2> page of the MAINTENANCE menu, you can store a white balance value for each of the built-in CC filters in memory A and B individually. In this case, a total of 8 white balance values can be stored as the camera has four CC filters. The settings of the filter select knobs are not stored when you adjust white balance with FILTER WHT MEM set to ON. In this case, the white balance in memory corresponding to the current WHITE BAL switch and CC filter select knob settings is retrieved when power is turned on again.

If automatic black balance or white balance adjustment fails

If the adjustment process does not end successfully, the error message "ABB: NG" or "AWB: NG" will be displayed on the viewfinder screen for approximately three seconds. If this error message is displayed, try the adjustment again. If the error message continues to be displayed after several attempts, the camera requires internal inspection.

Setting the Electronic Shutter

This section explains the different modes which can be used for the electronic shutter and gives the procedures for setting the shutter mode and shutter speed.

Note

When a CCU or an external control device, such as an RCP/RM or MSU, is connected, the electronic shutter is controlled from the external control device, and the switch on the camera is disabled.

About the shutter modes

The shutter modes that can be used with the electronic shutter of the camera and the shutter speeds that may be selected are as follows:

Shutter mode	Shutter speed 1)	Usage
Standard	1/100, 1/125, 1/250, 1/500, 1/1000, 1/2000 seconds	Use to obtain clear images of quickly moving subjects
ECS (Extended Clear Scan)	Continuously variable in the range of 60.0 Hz to 4300 Hz	Use to obtain images of video monitors without horizontal striping

1) The values in the table are those with 59.94i. With other formats, the available values may be different.

Note

With artificial lighting, particularly fluorescent lights and mercury vapor lamps, the brightness appears to be constant, but in fact the strength of the red, green, and blue components varies with the power supply frequency. This phenomenon is known as "flicker." When using the electronic shutter under these lighting conditions, there are certain cases in which the flicker is more noticeable. In particular, color flicker is evident when the power frequency is 60 Hz. In areas where the power frequency is 50 Hz, setting the shutter speed to 1/100 second will reduce the flicker.

Selecting the mode and speed of the shutter

The mode and the shutter speed in Standard mode are set using the SHUTTER switch.

- 1 Push the SHUTTER switch from the ON position to the SEL position.

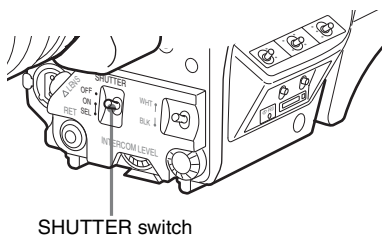

The current shutter setting will be displayed in the viewfinder for about three seconds.
Example: "Shutter: 1/250"

- 2 Push the SHUTTER switch to the SEL position again before the display disappears. Repeat this action until the desired mode or speed is displayed.

Example: with 59.94i

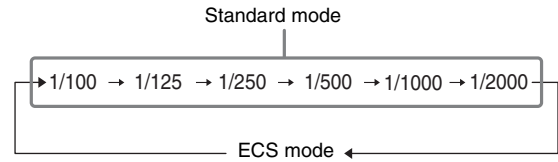

Setting the Local Time

When using the camera for the first time, set the built-in clock to the local time, using the <DATE> page of the MAINTENANCE menu displayed on the viewfinder screen.
For details on menu operations, see "Menus" (page 22).

- 1 Turn on the camera.
- 2 While holding the menu control knob pressed, set the DISPLAY/MENU switch to MENU.
The camera enters Menu mode, and "TOP" is displayed at the upper-right corner of the screen.
- 3 Rotate the menu control knob to set the cursor to "TOP" and push on the menu control knob.
The TOP MENU screen is displayed.

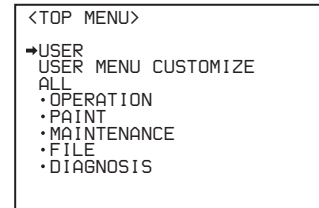

- 4 Rotate the menu control knob to position the cursor to MAINTENANCE and push on the menu control knob.
The CONTENTS page of the MAINTENANCE menu is displayed.

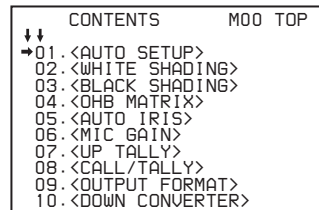

- 5 Turn the menu control knob to scroll the page and position the pointer to <DATE> then push on the menu control knob.
The <DATE> page is displayed.

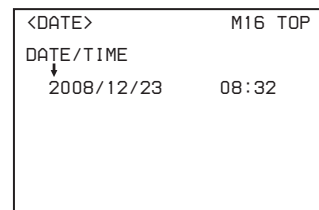

- 6** Turn the menu control knob and set the date and time. Push on the menu control knob to shift to the next digit.
- 7** When the date/time setting is completed, set the DISPLAY/MENU switch to OFF to exit Menu mode.

Adjusting the Flange Focal Length

Adjustment of the flange focal length (the distance between the lens mount attachment plane and the imaging plane) is necessary in the following situations:

- The first time a lens is attached
- When changing lenses
- If the focus is not sharp at both telephoto and wide angle when zooming

The flange focal length can be more precisely adjusted by using the focus assist indicators.

See "Displaying the focus assist indicators" (page 20) for the focus assist indicators.

Note

The various parts of the lens used in adjusting the flange focal length are in different positions on different lenses. Refer to the operation manual for the lens.

- 1** Set the iris control to manual and open the iris fully.
- 2** Place a flange focal length adjustment chart approximately 3 meters from the camera and adjust the lighting to get an appropriate video output level.

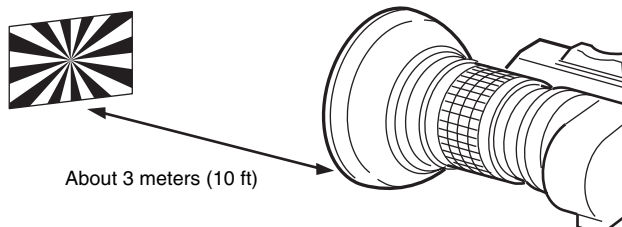

- 3** Loosen the Ff (flange focal length) ring lock screw.
- 4** With either manual or power zoom, set the zoom ring to telephoto.
- 5** Aim at the flange focal length adjustment chart and turn the focus ring to focus the image.
- 6** Set the zoom ring to wide angle.
- 7** Turn the Ff ring to bring the chart into focus. Take care not to move the distance ring.
- 8** Repeat steps 4 through 7 until the image is in focus at both telephoto and wide angle.
- 9** Tighten the Ff ring lock screw.

Setting the Focus Assist Function

Using the OPERATION menu, the assist functions for easier focusing on the viewfinder screen can be activated.

Adding a VF detail signal

Adding a VF detail signal to sharp edges in the image on the viewfinder screen makes it easier to check the focusing condition by observing changes in the detail signal or in the color converted from the detail signal (color detail).

The focus setting where the detail signal becomes strongest is the best focus setting.

- 1** Turn on the camera.
- 2** Set the the DISPLAY/MENU switch to MENU while holding the menu control knob pressed. The camera enters Menu mode, and "TOP" is displayed at the upper right corner of the screen.
- 3** Rotate the menu control knob to align the pointer to "TOP" and push on the knob. The TOP MENU screen is displayed.

```
<TOP MENU>
  →USER
  USER MENU CUSTOMIZE
  ALL
  • OPERATION
  • PAINT
  • MAINTENANCE
  • FILE
  • DIAGNOSIS
```

- 4** Rotate the menu control knob to align the pointer to OPERATION and push on the knob. The CONTENTS page of the OPERATION menu is displayed.

```
CONTENTS      00 TOP
↓ ↓
→01.<VF DISPLAY>
02.<'! 'IND>
03.<VF MARKER>
04.<VF DETAIL>
05.<FOCUS ASSIST>
06.<ZEBRA>
07.<CURSOR>
08.<VF OUT>
09.<SWITCH ASSIGN1>
10.<SWITCH ASSIGN2>
```

- 5** Rotate the menu control knob to align the pointer to <VF DETAIL> and push on the knob. The <VF DETAIL> page is displayed.

```
<VF DETAIL>      → 04 TOP
VF DETAIL : ON      25%
CRISP      : 0
FREQUENCY  : 9M
FAT MODE   : OFF
FLICKER    : OFF
AREA       : 70%
ZOOM LINK  : 100%
COLOR DETAIL : ON   BLUE
PEAK COLOR : ON
CHROMA LEVEL : 100%
```

- 6** Rotate the menu control knob to align the pointer to the item to be set and push on the knob.

To use the VF detail signal

Set VF DETAIL to ON to activate the VF detail function to add the detail signal to sharp edges in the image. You can

adjust the signal level (strength) in the range of 0 to 100% (default 25%).

You can adjust the characteristics of the detail signal with the menu items below:

CRISP: Adjust to eliminate fine portions of the detail signal.

FREQUENCY: Change the detection band of sharp edges.

FAT MODE: Turn the function ON/OFF to thicken the detail signal.

FLICKER: Turn the function ON/OFF to flicker the detail signal, which makes it easier to check the signal on a CRT screen.

AREA: To limit the area where to display the detail signal.

ZOOM LINK: Set the VF detail level at the full WIDE position. (The VF detail level changes according to the zoom position.)

To use the color detail

Set COLOR DETAIL to ON to convert the VF detail signal to a specified color. This makes it easier to check the signal on an LCD screen, including the viewfinder screen. The display color can be selected at the column next to ON.

You can adjust the coloring with the menu items below:

PEAK COLOR: Turn the function ON/OFF to change the color where the detail signal is strongest.

CHROMA LEVEL: To reduce the chroma components of the video signal (only for video signals on the viewfinder).

7 Rotate the menu control knob to display the desired setting and push on the knob.

8 To finish the adjustments, set the DISPLAY/MENU switch to OFF to exit Menu mode.

Displaying the focus assist indicators

The focus assist indicator function extracts the irregularities of a subject and converts the integrated values to a level indicator, which shows the focus condition.

Level indicator (Its position and operations can be adjusted.)

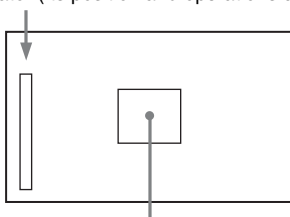

Area marker to display the detection area of the focus (Its size and position can be adjusted.)

The focus setting where the indicator shows the maximum level is the best focus setting. (The range of the indicator substantially changes depending on picture elements or shooting environments. Adjust it with GAIN and OFFSET as required.)

1 Display the CONTENTS page of the OPERATION menu (referring to step 1 to 4 in “Adding a VF detail signal”).

2 Rotate the menu control knob to align the pointer to <FOCUS ASSIST> and push on the menu control knob.

The <FOCUS ASSIST> page is displayed.

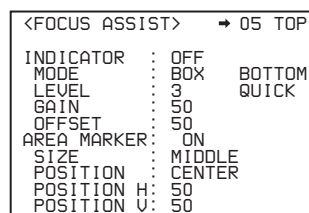

3 Rotate the menu control knob to align the pointer to the item to be set and push on the knob.

To use the level indicator

Setting INDICATOR to ON displays the level indicator on the viewfinder.

You can set the display format with the menu items below.

MODE: Set the type and position of the indicator.

LEVEL: Set the density and the response speed of the indicator.

GAIN: Set the sensitivity of the indicator.¹⁾

OFFSET: Set the offset of the focus detection value.²⁾

1) Normally, the sensitivity of the indicator is automatically set to the optimum value in conjunction with the AREA MARKER SIZE set value. Use this setting when an optimum sensitivity value cannot be obtained, depending on the shooting environment.

2) Normally, the optimum offset is automatically set in conjunction with the AREA MARKER SIZE and MASTER GAIN set values. Use this setting when the optimum offset cannot be obtained, depending on the shooting environment.

To use the area marker

Setting AREA MARKER to ON displays the detection area of the focus as a marker on the viewfinder screen.

You can set the size and position of the detection area with the menu items below.

SIZE: The size of the detection area can be changed. (If the area size is too large, both the subject and the background are included in the area, making the indicator display easily deviate from the subject.)

POSITION: Roughly set the position of the detection area.

POSITION H: Finely adjust the position of the detection area in the horizontal directions.

POSITION V: Finely adjust the position of the detection area in the vertical directions.

4 Rotate the menu control knob to display the desired setting and push on the knob.

5 To finish the adjustments, set the DISPLAY/MENU switch to OFF to exit Menu mode.

Notes

- The level indicator and the effect area marker cannot be displayed simultaneously, whichever you set to ON later is preferentially displayed.
- The area marker and the aspect safety marker cannot be displayed simultaneously, whichever you set to ON later is preferentially displayed.
- When displaying the focus assist indicators, check that the flange focal length has been precisely adjusted.

See “Adjusting the Flange Focal Length” (page 19) for the flange focal length.

Setting the Camera Outputs

You can specify video signals directly output from the camera, with menu operations.

Note

The MAIN (camera picture), RET (return video), or VF (the same picture as that displayed on the viewfinder screen) setting is common to SD-SDI and VBS. Different signals cannot be output.

The menu pages used for the output settings have been registered to the USER menu at the factory.

- <POWER SAVE> (U11)
- <OUTPUT FORMAT> (U16)
- <TEST OUT> (U17)
- <SDI OUT> (U18)
- <DOWN CONVERTER> (U19)

Set the menu items on the above menu pages to the settings shown in the following tables.

For details on menu operations and the USER menu, see “Menus” on page 22.

Outputting the signal being shot (camera picture)

The same textual information as that displayed on the viewfinder screen can be added to the output signal by setting CHARACTER to ON on the <SDI OUT> or <TEST OUT> page.

To output as HD-SDI

Menu page	Item	Setting
<POWER SAVE>	SDI OUT	ACTIVE
<SDI OUT>	OUTPUT	MAIN

To output as SD-SDI

Menu page	Item	Setting
<POWER SAVE>	SDI OUT	ACTIVE
	DOWN CONVERTER	ACTIVE
<DOWN CONVERTER>	OUTPUT SIGNAL	MAIN
<SDI OUT>	OUTPUT	SD-SDI

To output as VBS

Menu page	Item	Setting
<POWER SAVE>	DOWN CONVERTER	ACTIVE
<DOWN CONVERTER>	OUTPUT SIGNAL	MAIN
<TEST OUT>	OUTPUT	VBS

Constantly outputting a return video

- When a CCU is connected, one of the signals being supplied to the CCU can be output from the camera.
- The last selected return signal is output.
- The same character information as that displayed on the viewfinder screen can be added to the output signal by

setting CHARACTER to ON on the <SDI OUT> or <TEST OUT> page.

To output as HD-SDI

Menu page	Item	Setting
<POWER SAVE>	SDI OUT	ACTIVE
<SDI OUT>	OUTPUT	RET

To output as SD-SDI

Menu page	Item	Setting
<POWER SAVE>	SDI OUT	ACTIVE
	DOWN CONVERTER	ACTIVE
<DOWN CONVERTER>	OUTPUT SIGNAL	RET
<SDI OUT>	OUTPUT	SD-SDI

To output as VBS

Menu page	Item	Setting
<POWER SAVE>	DOWN CONVERTER	ACTIVE
<DOWN CONVERTER>	OUTPUT SIGNAL	RET
<TEST OUT>	OUTPUT	VBS

Outputting the same image as that on the viewfinder screen

- With HD-SDI, you can obtain a signal that includes the same information as that being displayed on the viewfinder according to the settings for VF MARKER, CHARACTER, VF DETAIL, ZEBRA, etc. The ON/OFF or other settings for adding information are common to those for the viewfinder. The output is synchronized with switching among Y, R, G, and B or switching to a return signal.
- With SD-SDI or VBS, the output is synchronized only with switching between a return signal and the camera image. It does not correspond to switching among Y, R, G, and B. Information other than CHARACTER (such as VF MARKER, VF DETAIL, and ZEBRA) cannot be added to the output.

Note

With the settings for outputting the same image as that on the viewfinder, the output will be obtained in 1080i, even if the format setting is 720P.

To output as HD-SDI

Menu page	Item	Setting
<POWER SAVE>	SDI OUT	ACTIVE
<SDI OUT>	OUTPUT	VF

To output as SD-SDI

Menu page	Item	Setting
<POWER SAVE>	SDI OUT	ACTIVE
	DOWN CONVERTER	ACTIVE
<DOWN CONVERTER>	OUTPUT SIGNAL	VF
<SDI OUT>	OUTPUT	SD-SDI

To output as VBS

Menu page	Item	Setting
<POWER SAVE>	DOWN CONVERTER	ACTIVE
<DOWN CONVERTER>	OUTPUT SIGNAL	VF
<TEST OUT>	OUTPUT	VBS

Outputting a prompter signal (when an HSCU-300 is connected)

There are two types of prompter signals (VBS and SDI) which are selected using a menu of the connected CCU.

In the case of the VBS prompter

Two prompter lines can be used at the same time.

- The VBS signal supplied to the PROMPTER 1 connector of the CCU is output from the PROMPTER/GENLOCK/RET IN connector of the camera.
- The VBS signal supplied to the PROMPTER 2 connector of the CCU is output from the TEST OUT connector of the camera.

To output the PROMPTER 2 signal from the TEST OUT connector

Menu page	Item	Setting
<TEST OUT>	OUTPUT	PROMPTER2

In the case of the SDI prompter

Either HD-SDI or SD-SDI can be input.

- The signal supplied to the SDI RET connector of the CCU is output from the SDI connector of the camera.
- Menus of the CCU are used for switching between SDI RET1 and SDI RET2 of the CCU input connectors, as well as between HD-SDI and SD-SDI.

To output the SDI PROMPTER signal from the SDI connector

Menu page	Item	Setting
<SDI OUT>	OUTPUT	SDI-PROMPTER

Outputting a prompter signal (when an HXCU-100 is connected)

A VBS signal input to the PROMPTER connector on a CCU is output from the PROMPTER/GENLOCK/RET IN connector of this unit.

Outputting a Trunk Signal

The trunk signal can be used for communication between an external device connected to the REMOTE connector of the camera and an external device connected to the TRUNK connector of the CCU.

To output the trunk signal from the REMOTE connector

Menu page	Item	Setting
<TRUNK>	TRUNK	ON

Menus

The menus displayed on the viewfinder screen enable various settings of the camera.

The following controls are used to operate the menus.

To enter Menu mode, you can use the DISPLAY/MENU switch either on the side or on the rear operation panel.

The menu control knob at the low on the front panel and that on the rear operation panel function the same. Rotate the knob to select menu items or values and push on it to register (enter) the selection.

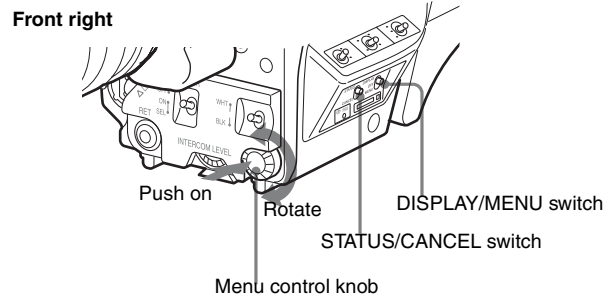

Rear operation panel

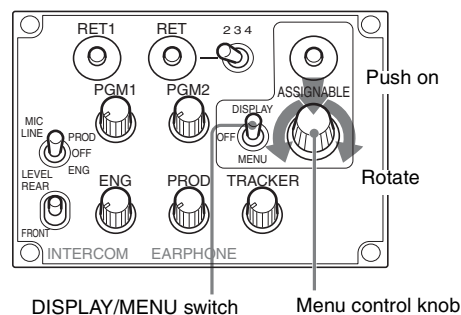

Displaying Menu Pages

To display a menu page

Set the DISPLAY/MENU switch to MENU.

The menu page last accessed will be displayed. If it is the first time, the CONTENTS page of the USER menu will be displayed.

To display the TOP MENU screen

If you set the DISPLAY/MENU switch to MENU while holding the menu control knob pressed, "TOP" is displayed at the upper right corner of the screen.

Turn the menu control knob to move the pointer (➡) on the display to "TOP" and push on the knob. The TOP MENU screen is displayed, listing the available menus.

<TOP MENU> →USER USER MENU CUSTOMIZE ALL •OPERATION •PAINT •MAINTENANCE •FILE •DIAGNOSIS
--

Menu	Purpose
USER	This menu can include menu pages selected from among the OPERATION, PAINT, MAINTENANCE, FILE, and DIAGNOSIS menus, for convenience. Changing, adding, and deleting pages can be performed with the USER MENU CUSTOMIZE menu.
USER MENU CUSTOMIZE	This menu allows you to edit the USER menu. <i>For details on the USER menu, see "Editing the USER Menu" (page 24).</i>
ALL	This menu permits you to control all items of the OPERATION menu, PAINT menu, MAINTENANCE menu, FILE menu, and DIAGNOSIS menu as a single menu.
OPERATION	This menu contains items for camera operators to operate the camera. It mainly permits viewfinder, intercom, and switch settings.
PAINT	This menu contains items for making detailed image adjustments while using a waveform monitor to monitor the waveforms output from the camera. Support of a video engineer is usually required to use this menu. Although you can also use an external control device to set the items on this menu, the menu is effective when using the camera by itself outdoors.
MAINTENANCE	This menu contains items for performing camera maintenance operations, such as changing the system or setting infrequently used "paint" items.
FILE	This menu is for performing file operations, such as writing or clearing the reference file.
DIAGNOSIS	This menu enables you to confirm the self-diagnostic information.

To disable the "TOP" indication

Turn the power off then on again, or set the DISPLAY/MENU switch to MENU while holding the STATUS/ CANCEL switch pressed toward CANCEL. This disables the TOP selection.

Setting the Menu

To select a menu on the TOP MENU screen

Rotate the menu control knob to align the pointer with the desired menu indication then push on the knob. The CONTENTS page (page No. 00) or the last accessed page of the selected menu is displayed.

To select a page from a CONTENTS page

Rotate the menu control knob to align the pointer with the desired page indication then push on the menu control knob.

If the screen can be scrolled, arrows will indicate the direction for scrolling.

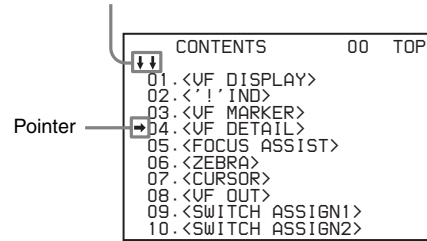

The selected page is displayed.

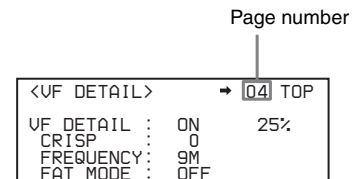

To change the displayed page

- 1 Check that the pointer is located at the left of the page number then push on the menu control knob. The pointer changes to a flashing question mark.

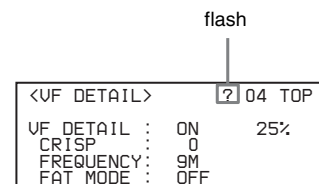

- 2 Rotate the menu control knob to flip through the pages, and push on the knob when the desired page is displayed.

The question mark will change back to the pointer, and operations with the displayed page are enabled.

To return to the TOP MENU screen

Align the pointer with "TOP" at the top right of the menu page then push on the menu control knob.

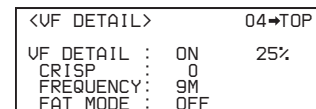

To set the Menu Items

If a question mark is flashing at the left of the page number, push on the menu control knob to change it to the pointer. Operation on the displayed page is enabled.

- 1 Align the pointer with the desired item, then push on the menu control knob. The pointer will change to a flashing question mark.
- 2 Rotate the menu control knob to change the setting value. When the knob is rotated quickly, the values will change quickly; when rotated slowly, the values will change slowly.

To reset a changed value

If you press the STATUS/ CANCEL switch toward CANCEL before pushing on the menu control knob, the setting will be returned to its previous value.

To interrupt settings

Set the DISPLAY/MENU switch to OFF to turn off the menu screen display.

The setting operation can be restarted by setting the DISPLAY/MENU switch back to MENU.

3 Push on the menu control knob.

The question mark will change back to the pointer, and the new setting will be registered.

4 To change other setting items on the same menu page, repeat steps 1 through 3.

To specify a character string

When you press the menu control knob with the pointer pointing to an item for which a character string, such as a file ID, is to be specified, a cursor and the list of selectable characters are displayed.

The displayed cursor can be moved by rotating the menu control knob.

1 Set the cursor to the position where you wish enter a character, then push on the menu control knob.

Another cursor appears on the character list.

2 Set the cursor to the character to be entered and push on the menu control knob.

Repeat steps 1 and 2.

- By selecting INS on the line below the character list, you can enter a space at the cursor position.
- Selecting DEL deletes the character at the cursor position.
- You can return to step 1 without changing the character by selecting RET.
- If you enter the permitted maximum number of characters (up to the stop mark at the right end of the line), the cursor moves to ESC on the line below the character list.

3 Select END and push on the menu control knob.

The new string you have set is registered.

To restore the previous string, select ESC and push on the menu control knob.

To return a menu item to its standard value

Select the menu item to be returned to its standard value then hold the menu control knob pressed for 3 seconds while the arrow marker (➡) is displayed.

If "10 SEC CLEAR" has been set to ON on the <FILE CLEAR> page of the FILE menu, you can return the setting in the reference file for the item being selected to the factory-set value by holding the menu control knob pressed for another 10 seconds.

To end menu operations

Set the DISPLAY/MENU switch to OFF.

Editing the USER Menu

You can select desired pages and items from the OPERATION, PAINT, MAINTENANCE, FILE, and DIAGNOSIS menus and register them to the USER menu. If you specify pages or items frequently used for the USER menu, you can easily call and use them.

The following pages are included on the factory-set USER menu:

Menu page title	USER menu No.	Source menu / page No.
<VF OUT>	U01	OPERATION 08
<VF DETAIL>	U02	OPERATION 04
<FOCUS ASSIST>	U03	OPERATION 05
<VF DISPLAY>	U04	OPERATION 01
<'! IND>	U05	OPERATION 02
<VF MARKER>	U06	OPERATION 03
<CURSOR>	U07	OPERATION 07
<ZEBRA>	U08	OPERATION 06
<SWITCH ASSIGN1>	U09	OPERATION 09
<SWITCH ASSIGN2>	U10	OPERATION 10
<POWER SAVE>	U11	MAINTENANCE M13
<LENS FILE>	U12	OPERATION 17
<HEAD SET>	U13	OPERATION 11
<INTERCOM LEVEL>	U14	OPERATION 12
<MIC GAIN>	U15	MAINTENANCE M06
<OUTPUT FORMAT>	U16	MAINTENANCE M09
<TEST OUT>	U17	MAINTENANCE M11
<SDI OUT>	U18	MAINTENANCE M12
<DOWN CONVERTER>	U19	MAINTENANCE M10
<TRUNK>	U20	MAINTENANCE M14
<UP TALLY>	U21	MAINTENANCE M07
<ROM VERSION>	U22	DIAGNOSIS D03

For the items on each page, see "OPERATION Menu" (page 27), "MAINTENANCE Menu" (page 33), or "DIAGNOSIS Menu" (page 37).

The USER MENU CUSTOMIZE menu allows you to configure the USER menu as follows:

- Creating a new page with items selected from multiple menu pages
- Adding (registering) a menu page (new page you create or existing menu page) to the USER menu
- Deleting (unregistering) a page from the USER menu
- Changing the order of pages of the USER menu

Editing by items

While the EDIT page contains factory-preset items, the USER 1 EDIT to USER 19 EDIT pages are all blank in their initial state. You can register up to 10 items, including blank lines, on each of these pages.

To add items to a page

1 Select USER MENU CUSTOMIZE on the TOP MENU screen (page 22).

If this is the first time the USER MENU CUSTOMIZE menu has been displayed, the CONTENTS page of the menu appears.

```

CONTENTS      E00 TOP
↓↓
01.EDIT PAGE
02.USER 1 EDIT
→03.USER 2 EDIT
04.USER 3 EDIT
05.USER 4 EDIT
06.USER 5 EDIT
07.USER 6 EDIT
08.USER 7 EDIT
09.USER 8 EDIT
10.USER 9 EDIT
    
```

If the USER MENU CUSTOMIZE menu has been used before, the page last accessed appears.

2 If the CONTENTS page is displayed, turn the menu control knob to move the pointer to any of USER 1 EDIT to USER 19 EDIT then push on the menu control knob to display the page.

If a different page is displayed, turn the menu control knob until the desired page appears then push on the menu control knob to select the page.

Example: When you select the USER 2 EDIT page

```

USER 2 EDIT  E03 TOP
→
    
```

3 Move the pointer to the item to be added (this operation is unnecessary if no item exists on the page, as shown in the figure for the previous step) then push on the menu control knob.

The EDIT FUNCTION screen appears.

```

EDIT FUNCTION  ESC
→INSERT
MOVE
DELETE
BLANK
    
```

4 Move the pointer to INSERT and push on the menu control knob.

The page with the last item added appears.

```

<SW STATUS>      P01 ESC
FLARE      :→ ON
GAMMA      : ON
BLK_GAM    : OFF
KNEE       : ON
WHT_CLIP   : ON
DETAIL     : ON
LVL_DEP    : ON
SKIN_DTL   : OFF
MATRIX     : OFF
    
```

5 Add the items.

- ① Turn the menu control knob until the page that has the desired items appears, then push on the menu control knob.
- ② Turn the menu control knob to move the pointer to the desired item, then push on the menu control knob

The USER 2 EDIT page appears again, displaying the newly added item.

6 Add the remaining items by repeating steps 3 to 5. You can add up to 10 items on one page.

To change the order of items on a page

1 Move the pointer to the item to be moved then push on the menu control knob.

The EDIT FUNCTION screen appears.

2 Select MOVE then push on the menu control knob.

The previously displayed page appears again.

3 Move the pointer to the position where you wish to move the item then push on the menu control knob.

```

ITEM MOVE      ESC
↓↓
→VF OUT       : COLOR
VF DETAIL      : OFF
MARKER         : ON
CURSOR         : OFF
ZEBRA SW       : OFF
●ASSIGNABLE1   : OFF
    
```

The item selected in step 1 moves to the position that you selected in step 3.

In the above example, ASSIGNABLE1 is moved to the top, and the other items are moved down one line.

To delete items from a page

1 Move the pointer to the item to be deleted then push on the menu control knob.

The EDIT FUNCTION screen appears.

2 Select DELETE and push on the menu control knob.

The previously displayed page appears again, and the message "DELETE OK? YES→NO" appears.

3 To delete, turn the menu control knob to move the pointer to YES and push on the menu control knob.

To insert a blank line

1 Move the pointer to the item above which you wish to insert a blank line.

The EDIT FUNCTION screen appears.

2 Select BLANK then push on the menu control knob.

The previously displayed page appears again, and a blank line is inserted above the specified item.

Note

You cannot insert a blank line on a page where 10 items have already been registered.

Editing by pages

You can add a page to the USER menu, delete a page from the USER menu, or replace pages, using the EDIT PAGE of the USER MENU CUSTOMIZE menu.

To add a page

1 Select USER MENU CUSTOMIZE on the TOP MENU screen.

If this is the first time the USER MENU CUSTOMIZE menu has been displayed, the CONTENTS page of the menu appears. If the menu has been used before, the page last accessed appears.

2 If the CONTENTS page is displayed, turn the menu control knob to move the pointer to EDIT PAGE then push on the menu control knob to display the EDIT PAGE screen.

If a different page is displayed, turn the menu control knob until the EDIT PAGE screen appears then push on the menu control knob to select the page.

```
EDIT PAGE      E01 TOP
↓ ↓
01.<VF OUT>
→02.<VF DETAIL>
03.<FOCUS ASSIST>
04.<VF DISPLAY>
05.<'I' IND>
06.<VF MARKER>
07.<CURSOR>
08.<ZEBRA>
09.<SWITCH ASSIGN1>
10.<SWITCH ASSIGN2>
```

3 Move the pointer to the position where you wish to add the page then push on the menu control knob.

The EDIT FUNCTION screen appears.

4 Select INSERT then push on the menu control knob.

The selection screen appears.

```
CONTENTS      ESC
↓ ↓
→01.USER 1
02.USER 2
03.USER 3
04.USER 4
05.USER 5
06.USER 6
07.USER 7
08.USER 8
09.USER 9
10.USER 10
```

5 Move the pointer to the desired page then push on the menu control knob.

This adds the number and name of the selected page above the item selected in step 3.

To cancel addition of a page

Before pushing the menu control knob in step 5, turn the menu control knob to move the pointer to ESC at the top right of the screen then push on the menu control knob. The EDIT PAGE screen appears again.

To delete a page

1 On the EDIT PAGE screen of the USER MENU CUSTOMIZE menu, move the pointer to the page to be deleted and push on the menu control knob.

The EDIT FUNCTION screen appears.

2 Select DELETE then push on the menu control knob.

The previously displayed page appears again, and the message "DELETE OK? YES→NO" appears.

```
ITEM DELETE      ESC
DELETE OK? YES→NO
01.<VF OUT>
02.<VF DETAIL>
03.<FOCUS ASSIST>
●04.<VF DISPLAY>
05.<'I' IND>
06.<VF MARKER>
07.<CURSOR>
08.<ZEBRA>
09.<SWITCH ASSIGN1>
10.<SWITCH ASSIGN2>
```

3 To delete, turn the menu control knob to move the pointer to YES then push on the menu control knob.

To change the order of pages

1 Display the EDIT PAGE screen of the USER MENU CUSTOMIZE menu. Turn the menu control knob to move the pointer to the page that you wish to move.

The EDIT FUNCTION screen appears.

2 Select MOVE then push on the menu control knob.

The EDIT PAGE screen appears again.

3 Move the pointer to the position where you wish to move the page then push on the menu control knob.

```
ITEM MOVE      ESC
↓ ↓
01.<VF OUT>
02.<VF DETAIL>
03.<FOCUS ASSIST>
→04.<VF DISPLAY>
05.<'I' IND>
06.<VF MARKER>
07.<CURSOR>
08.<ZEBRA>
●09.<SWITCH ASSIGN1>
10.<SWITCH ASSIGN2>
```

The page selected in step 1 is moved to the position selected in step 3.

In the above example, <SWITCH ASSIGN1> moves to the "04" position, and the <VF DISPLAY> and following pages move down one line.

OPERATION Menu

Note

These remarks are common for all the following menu tables.

ON, OFF, 0, ... , in the Settings columns: Default settings

Page No. nn (Unn): For the pages that have been registered on the USER menu at the factory, the USER menu page numbers are indicated in parenthesis.

Execute by ENTER: Execute by pushing on the menu control knob.

HDLA: HDLA1500-series

Page title Page No.	Item	Settings
<VF DISPLAY> 01(U04)	EX	ON , OFF
	ZOOM	ON, OFF
	DISP	LEFT , RIGHT
	FOCUS	ON, OFF
		Valid only when a serial lens is used
	ND	ON , OFF
	CC	ON , OFF
	5600K	ON , OFF
	IRIS	ON , OFF
	WHITE	ON, OFF
	GAIN	ON , OFF
	SHUTT	ON , OFF
	BATT	ON, OFF
	RETURN	ON , OFF
	TALK	ON , OFF
	MESSAG	ALL , AT, WRN, OFF ALL: To display all messages AT: To display Auto Setup information and higher WRN: To display warning messages and higher

Page title Page No.	Item	Settings
<'! IND> 02 (U05)		[IND]: Activate/deactivate the '! indication (<i>page 14</i>). [NORMAL]: Specify the conditions under which the '! indication is not to be displayed even if [IND] is ON. (By specifying the standard or normal conditions here, nonstandard or abnormal conditions can be found with the '! indication on the viewfinder.)
	ND	[IND] ON , OFF [NORMAL] 1 , 2, 3, 4 (combination allowed)
	CC	[IND] ON , OFF [NORMAL] A, B , C, D (combination allowed)
	WHITE	[IND] ON , OFF, - - - - - - : with CCU connected [NORMAL] P, A , B (combination allowed)
	5600K	[IND] ON , OFF, - - - - - - : with CCU connected [NORMAL] ON, OFF
	GAIN	[IND] ON , OFF, - - - - - - : with CCU connected [NORMAL] H, M, L (combination allowed)
	SHUTT	[IND] ON , OFF, - - - - - - : with CCU connected [NORMAL] ON, OFF
	FAN	[IND] ON , OFF [NORMAL] AUTO1 , AUTO2, MIN, MAX
	EXT	[IND] ON , OFF
	FORMAT	[IND] ON , OFF [NORMAL] UC model: 59.94i , 50i, 59.94P, 50P CE model: 59.94i, 50i , 59.94P, 50P

Page title Page No.	Item	Settings
<VF MARKER> 03 (U06)	MARKER	ON , OFF WHITE , BLACK, DOT
	CENTER	ON, OFF 1 , 2, 3, 4 1: Entire cross 2: Entire cross with a hole 3: Center 4: Center with a hole
	SAFETY ZONE	ON, OFF 80.0, 90.0 , 92.5, 95.0%
	EFFECT	ON, OFF , (FOCUS) (FOCUS): Displayed when INDICATOR of <FOCUS ASSIST> is ON.
	ASPECT	ON, OFF 16:9, 15:9, 14:9, 13:9, 4:3 , (4.3) (4.3): If VF SCAN is set to 4:3 when HDLA attached (cannot be changed)
	MASK	ON, OFF , (ON) (ON): If VF SCAN is set to 4:3 when HDLA attached (cannot be changed) 0 to 15 12 Set the level to darken outside the aspect area.
	SAFETY For the safety marker in Aspect mode	ON, OFF , (AREA) (AREA): Displayed when AREA MARKER of <FOCUS ASSIST> is ON. 80.0, 90.0 , 92.5, 95.0%
	<VF DETAIL> 04 (U02)	VF DETAIL
		ON , OFF, (ON), (OFF) Settings in (): When HDLA attached (cannot be changed) 0 to 100%, (0 to 100%), 25% Settings in (): When HDLA attached (cannot be changed)
		CRISP -99 to 99 0
	FREQUENCY 9M , 14M, 18M	
	FAT MODE ON, OFF	
	FLICKER ON, OFF	
	AREA 100% , 70%, 60%, 50%, 40%	
	ZOOM LINK 0%, 25%, 50%, 75%, 100%	
	COLOR DETAIL ON, OFF BLUE , RED, YELLOW	
	PEAK COLOR ON, OFF	
	CHROMA LEVEL 100%, 50%, 25% , 0%	

Page title Page No.	Item	Settings
<FOCUS ASSIST> 05 (U03)	INDICATOR	ON, OFF , (EFFECT) (EFFECT): Displayed when EFFECT of <VF MARKER> is ON.
	MODE	BOX , B&W, COL BOTTOM , LEFT, TOP, RIGHT
	LEVEL	1 to 5 3 QUICK , SMOOTH
	GAIN	0 to 99 50
	OFFSET	0 to 99 50
	AREA MARKER	ON, OFF , (ASPECT) (ASPECT): Displayed when ASPECT SAFETY of <VF MARKER> is ON.
	SIZE	SMALL, MIDDLE , LARGE
	POSITION	LEFT, CENTER , RIGHT
	POSITION H	0 to 99 50
	POSITION V	0 to 99 50
<ZEBRA> 06 (U08)	ZEBRA	ON, OFF 1 , 2, 1&2
	ZEBRA1 LEVEL	50 to 109% 70
	WIDTH	0 to 30% 10
	ZEBRA2	50 to 109% 100
<CURSOR> 07 (U07)	CURSOR	ON, OFF Display only if HDLA attached WHITE , BLACK, DOT
	BOX/CROSS	BOX , CROSS
	H POSITION	0 to 99 50 Display only if HDLA attached
	V POSITION	0 to 99 50 Display only if HDLA attached
	WIDTH	0 to 99 50 Display only if HDLA attached
	HEIGHT	0 to 99 50 Display only if HDLA attached

Page title Page No.	Item	Settings
<VF OUT> 08 (U01)	VF OUT	COLOR , Y, R, G, B, (COLOR), (Y), (R), (G), (B), (RET), (R+G), (R+B), (G+B) Settings in (): When HDLA attached (cannot be changed)
	RET MIX VF	ON, OFF , (ON), (OFF) Settings in (): When HDLA attached (cannot be changed)
	MIX DIRECTION	MAIN, RET
	MIX VF MODE	Y-MIX , WIRE(W), WIRE(B)
	MIX VF LEVEL	0 to 80 %
	VF SCAN	16:9 , 4:3
<SWITCH ASSIGN1> 09 (U09)	GAIN	[L]: -3, 0 , 3, 6, 9, 12 dB [M]: -3, 0, 3, 6 , 9, 12 dB [H]: -3, 0, 3, 6, 9, 12 dB
	ASSIGNABLE 1	UC model: OFF , RETURN1 SW, RETURN2 SW, INCOM, VF DETAIL, MIX VF, 5600K, FAN MAX, - - -
	ASSIGNABLE 2	CE model: OFF , RETURN1 SW, RETURN2 SW, ENG, PROD, VF DETAIL, MIX VF, 5600K, FAN MAX, - - - - - -: When HDLA attached
	ASSIGNABLE REAR	UC model: OFF , RETURN1 SW, RETURN2 SW, INCOM, VF DETAIL, MIX VF, 5600K, FAN MAX, VF SCAN, CURSOR, MARKER, - - - CE model: OFF , RETURN1 SW, RETURN2 SW, ENG, PROD, VF DETAIL, MIX VF, 5600K, FAN MAX, VF SCAN, CURSOR, MARKER, - - - - - -: When HDLA attached
	ASSIGNABLE HDLA Only when HDLA attached	OFF , EXTENDER, 5600K, FAN MAX
RE.ROTATION Specify operation mode of the menu control knob on the front.	STD , RVS STD: Clockwise rotation moves the pointer down or increases values on the menu screen. RVS: Counterclockwise rotation moves the pointer down or increases values on the menu screen.	

Page title Page No.	Item	Settings
<SWITCH ASSIGN2> 10 (U10)	LENS VTR S/S Assign a function to the VTR START/STOP switch on the mounted lens.	UC model: OFF, RETURN1 SW, RETURN2 SW , INCOM CE model: OFF, RETURN1 SW, RETURN2 SW , ENG, PROD
	FRONT RET2	
	HANDLE SW1	UC model: OFF, RETURN1 SW , RETURN2 SW, INCOM, ZOOM(T) CE model: OFF, RETURN1 SW , RETURN2 SW, ENG, PROD, ZOOM(T)
	HANDLE SW2	UC model: OFF, RETURN1 SW, RETURN2 SW, INCOM , ZOOM(W) CE model: OFF, RETURN1 SW, RETURN2 SW, ENG , PROD, ZOOM(W)
<HEAD SET> 11 (U13)	ZOOM SPEED	0 to 99 20
	INTERCOM MIC	DYNAMIC , CARBON, MANUAL
	LEVEL	-60,-40,-20 dB, (-60 dB) Settings in (): With DYNAMIC or CARBON (cannot be changed)
<INTERCOM LEVEL> 12 (U14)		-6, 0 , 6 dB Input gain
	POWER	ON, OFF, (ON), (OFF) Settings in (): With DYNAMIC or CARBON (cannot be changed)
	UNBAL	ON , OFF, (ON), (OFF) Settings in (): With CARBON (cannot be changed)
<INTERCOM LEVEL> 12 (U14)	SIDE TONE	MU, 1 to 99, 50
<RECEIVE SEL1> 13	INTERCOM RECEIVE SELECT	SEPARATE, MIX
	INTERCOM UC model only	- - -, LEFT , RIGHT, BOTH
	ENG CE model only	- - -, LEFT , RIGHT, BOTH
	PROD CE model only	- - -, LEFT , RIGHT, BOTH
	PGM1	- - -, LEFT, RIGHT , BOTH
	PGM2	- - -, LEFT, RIGHT , BOTH
	TRACKER	- - -, LEFT , RIGHT, BOTH

Page title Page No.	Item	Settings
<RECEIVE SEL2> 14	TRACKER RECEIVE SELECT	SEPARATE, MIX
	INTERCOM UC model only	- - -, LEFT , RIGHT, BOTH
	TALK CE model only	- - -, LEFT , RIGHT, BOTH
	ENG CE model only	- - -, LEFT , RIGHT, BOTH
	PROD CE model only	- - -, LEFT , RIGHT, BOTH
	PGM1	- - -, LEFT, RIGHT , BOTH
	PGM2	- - -, LEFT, RIGHT , BOTH
<RECEIVE SEL3> 15	EARPHONE RECEIVE SELECT	SEPARATE, MIX
	INTERCOM UC model only	- - -, LEFT , RIGHT, BOTH,
	ENG CE model only	- - -, LEFT , RIGHT, BOTH
	PROD CE model only	- - -, LEFT , RIGHT, BOTH
	PGM1	- - -, LEFT, RIGHT , BOTH
	PGM2	- - -, LEFT, RIGHT , BOTH
	TRACKER	- - -, LEFT , RIGHT, BOTH
<OPERATOR FILE> 16 <i>See FILE menu F01.</i>	READ (MS→CAM)	Execute by ENTER.
	WRITE (CAM→MS)	Execute by ENTER.
	PRESET	Execute by ENTER.
	FILE ID	Max.16 characters
	CAM CODE	Display only
	DATE	Display only
<LENS FILE> 17 (U12)	FILE	1 to 17: 1 to 16: When using a non-serial lens 17: When using a serial lens Lens file name Changeable only when using a non-serial lens F-stop number of the lens Changeable only when using a non-serial lens
	CENTER MARKER To set and store the center marker position.	
	H POS	-20 to 20 0 Increasing the value moves it to the right.
	V POS	-20 to 20 0 Increasing the value moves it downwards.
	STORE	Execute by ENTER.

PAINT Menu

Page title Page No.	Item	Settings
<SW STATUS> P01	FLARE	ON , OFF
	GAMMA	ON , OFF
	BLK GAM	ON, OFF
	KNEE	ON , OFF
	WHT CLIP	ON , OFF
	DETAIL	ON , OFF
	LVL DEP	ON , OFF
	SKIN DTL	ON, OFF
	MATRIX	ON, OFF
	<VIDEO LEVEL> P02	WHITE
BLACK		R/G/B/M: -99 to 99 0
FLARE		R/G/B: -99 to 99 0
GAMMA		R/G/B/M: -99 to 99 0
V MOD		R/G/B/M: -99 to 99 0
FLARE		ON , OFF
V MOD		ON , OFF
D. SHAD		ON, OFF Selectable only when a lens supporting dynamic shading is used.
TEST		OFF , SAW, 3STEP, 10STEP
<COLOR TEMP> P03		WHITE
	AUTO WHITE BALANCE	Execute by ENTER.
	COLOR TEMP	0K to 65535K 3200K
	BALANCE	-99 to 99 0
	ATW	ON, OFF
	SPEED	1 to 5 4
MASTER	-3.0dB to 12.0dB, 0.0dB	

Page title Page No.	Item	Settings
<GAMMA> P04	LEVEL	R/G/B/M: -99 to 99 0
	COARSE	0.35 to 0.45 to 0.90 (0.05 steps)
	TABLE	STANDARD , HYPER With STANDARD selected: UC model: 1, 2, 3 , 4, 5, 6, 7 CE model: 1, 2, 3, 4, 5, 6, 7 1: equivalent to a camcorder 2: 4.5-times gain 3: 3.5-times gain 4: equivalent to SMPTE-240M 5: equivalent to ITU-R709 6: 5.0-times gain 7: 5.0-times gain - 709 With HYPER selected: 1, 2, 3, 4 1: 325% to 100% 2: 460% to 100% 3: 325% to 109% 4: 460% to 109% (When you change the TABLE setting, noise may be generated. This is not malfunction.)
GAMMA	ON , OFF	
	TEST	OFF , SAW, 3 STEP, 10 STEP
<BLACK GAMMA> P05	LEVEL	-99 to 99 0 Master level only
	RANGE	LOW, L.MID, H.MID, HIGH ON , OFF
	TEST	OFF , SAW, 3 STEP, 10 STEP
<SATURATION> P06	SATURATION	-99 to 99 0 ON , OFF
	LOW KEY SAT	-99 to 99 0 ON , OFF
	TEST	OFF , SAW, 3 STEP, 10 STEP

Page title Page No.	Item	Settings	
<KNEE> P07	K POINT	R/G/B/M: -99 to 99 0	
	K SLOPE	R/G/B/M: -99 to 99 0	
	KNEE	ON , OFF	
	KNEE MAX	ON, OFF	
	KNEE SAT	-99 to 99 0 ON , OFF	
	AUTO KNEE	OFF , AUTO	
	POINT LIMIT	-99 to 99 0 SLOPE -99 to 99 0	
	ABS	When highlighted (ABS mode): K POINT R/G/B, K SLOPE R/G/B, and POINT LIMIT are displayed in absolute values.	
<WHITE CLIP> P08	W CLIP M	-99 to 99 0 ON , OFF	
	ABS	When highlighted (ABS mode): W CLIP M displayed in absolute values.	
<DETAIL 1> P09	DETAIL	ON , OFF	
	LEVEL	-99 to 99 0	
	LIMITER [M]	-99 to 99 0	
	LIMITER [WHT]	-99 to 99 0	
	LIMITER [BLK]	-99 to 99 0	
	CRISP	-99 to 99 0	
	LVL DEP	-99 to 99 0 ON , OFF	
	ABS	When highlighted (ABS mode): LEVEL, LIMITER WHT, LIMITER BLK, CRISP, and LVL DEP are displayed in absolute values.	
<DETAIL 2> P10	H/V RATIO	-99 to 99 0	
	FREQ	-99 to 99 0	
	MIX RATIO	-99 to 99 0	
	KNEE APT	-99 to 99 0 ON , OFF	
		ABS	When highlighted (ABS mode): H/V RATIO, FREQ, MIX RATIO, and KNEE APT are displayed in absolute values.

Page title Page No.	Item	Settings
<SKIN DETAIL> P11	SKIN DTL	ON, OFF
	SKIN GATE	ON, OFF , (MAT) (MAT): Displayed when GATE of <MULTI MATRIX> is ON.
	AUTO HUE	Execute by ENTER.
	PHASE	0 to 359
	WIDTH	0 to 90 29
	SAT	-99 to 99 -89
	LEVEL	-99 to 99 0
<USER MATRIX> P12	ABS	When highlighted (ABS mode): LEVEL is displayed in an absolute value.
	R-G	-99 to 99 0
	R-B	-99 to 99 0
	G-R	-99 to 99 0
	G-B	-99 to 99 0
	B-R	-99 to 99 0
	B-G	-99 to 99 0
	MATRIX	ON, OFF
	PRESET	ON , OFF, -- -- : When MATRIX is set to OFF (cannot be changed) SMPTE-240M, ITU-709 , SMPTE-WIDE, NTSC, EBU, ITU-601, -- -- : When MATRIX is set to OFF (cannot be changed)
	USER	ON, OFF , -- -- : When MATRIX is set to OFF (cannot be changed)
	MULTI	ON, OFF , -- -- : When MATRIX is set to OFF (cannot be changed)

Page title Page No.	Item	Settings
<MULTI MATRIX> P13	PHASE	0 , 23, 45, 68, 90, 113, 135, 158, 180, 203, 225, 248, 270, 293, 315, 338
	HUE	-99 to 99 0 Independently set for 16 axes.
	SAT	-99 to 99 0 Independently set for 16 axes.
	ALL CLEAR	Execute by ENTER. The HUE and SAT values for all PHASE settings are cleared.
	GATE	ON, OFF , (SKN) (SKN): Displayed when SKIN GATE of <SKIN DETAIL> is ON.
	MATRIX	ON, OFF
	PRESET	ON , OFF, -- -- : When MATRIX is set to OFF (cannot be changed) SMPTE-240M, ITU-709 , SMPTE-WIDE, NTSC, EBU, ITU-601, -- -- : When MATRIX is set to OFF (cannot be changed)
	USER	ON, OFF , -- -- : When MATRIX is set to OFF (cannot be changed)
	MULTI	ON, OFF , -- -- : When MATRIX is set to OFF (cannot be changed)
	<SHUTTER> P14	SHUTTER
ECS FREQ		59.94i: 60.00 to 4300 Hz 60.00 Hz (UC model) 50i: 50.00 to 4700 Hz 50.00 Hz (CE model) 59.94P: 59.96 to 4600 Hz 50P: 50.03 to 4600 Hz

Page title Page No.	Item	Settings
<SCENE FILE> P15 See "FILE menu" F02.	1	To store and read scene files (paint data).
	2	
	3	
	4	
	5	
	STORE	
	STANDARD	Execute by ENTER.
	READ (MS→CAM)	Execute by ENTER.
	WRITE (CAM→MS)	Execute by ENTER.
	FILE ID	Max.16 characters
	CAM CODE	Display only
	DATE	Display only

MAINTENANCE Menu

Page title Page No.	Item	Settings
<AUTO SETUP> M01	AUTO BLACK	Execute by ENTER.
	AUTO WHITE	Execute by ENTER.
	AUTO LEVEL	Execute by ENTER.
	AUTO WHITE SHADING	Execute by ENTER.
	AUTO BLACK SHADING	Execute by ENTER.
	TEST	OFF , SAW, 3STEP, 10STEP
<WHITE SHADING> M02	V SAW	R/G/B: -99 to 99 0
	V PARA	R/G/B: -99 to 99 0
	H SAW	R/G/B: -99 to 99 0
	H PARA	R/G/B: -99 to 99 0
	WHITE	R/G/B: -99 to 99 0
	AUTO WHITE SHADING	Execute by ENTER.
	WHITE SHAD MODE	RGB, RB
<BLACK SHADING> M03	V SAW	R/G/B: -99 to 99 0
	V PARA	R/G/B: -99 to 99 0
	H SAW	R/G/B: -99 to 99 0
	H PARA	R/G/B: -99 to 99 0
	BLK SET	R/G/B: -99 to 99 0
	BLACK	R/G/B/M: -99 to 99 0
	MASTER GAIN	-3, 0 , 3, 6, 9, 12 dB
	AUTO BLACK SHADING	Execute by ENTER.

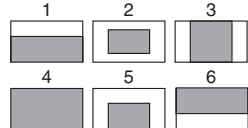
Page title Page No.	Item	Settings
<OHB MATRIX> M04	PHASE	0 , 23, 45, 68, 90, 113, 135, 158, 180, 203, 225, 248, 270, 293, 315, 338
	HUE	-99 to 99 0 Independently set for 16 axes.
	SAT	-99 to 99 0 Independently set for 16 axes.
	ALL CLEAR	Execute by ENTER. The HUE and SAT values for all PHASE settings are cleared.
	OHB MATRIX	ON, OFF
	MATRIX	ON, OFF
	<AUTO IRIS> M05	AUTO IRIS
WINDOW		1, 2, 3, 4, 5, 6 Select the auto iris windows: 
OVERVERRIDE		-99 to 99, -- Set the override to temporarily change the reference value for brightness of the automatic iris level in the range of ±2 steps. -99: Two steps to fully closed iris 99: Two steps to fully open iris -- : OFF The setting returns to "--" when the power is turned off.
	IRIS LEVEL	-99 to 99 0 ±4 steps
	APL RATIO	-99 to 99 65
	IRIS GAIN	-99 to 99 0
	IRIS CLOSE	ON, OFF
<MIC GAIN> M06 (U15)	MIC1	20 dB, 30 dB, 40 dB, 50 dB, 60 dB , (20 dB), (30 dB), (40 dB), (50 dB), (60 dB)
	MIC2	20 dB, 30 dB, 40 dB, 50 dB, 60 dB , (20 dB), (30 dB), (40 dB), (50 dB), (60 dB)
	FRONT MIC +48V	ON , OFF

Page title Page No.	Item	Settings
<UP TALLY> * M07 (U21) *Display on an HDLA	TALLY BRIGHTNESS	0 to 100 50
	NUMBER BRIGHTNESS	0 to 100 50
	CAMERA NUMBER	--, 1 to 96
	NUMBER DISPLAY	ON, OFF, AUTO AUTO: To correspond to the UP TALLY switch setting of HDLA attached
<CALL/TALLY> M08 Invalid when no CCU connected	CCU CALL	--, ON , OFF
	CAM CALL	--, ON, OFF
<OUTPUT FORMAT> M09 (U16)	CURRENT	Displays the current format.
	ACTIVE LINE Not displayed when a CCU connected	UC model: 1080 59.94i , 1080 50i, 720 59.94P, 720 50P CE model: 1080 59.94i, 1080 50i , 720 59.94P, 720 50P (When you change the ACTIVE LINE setting, once turn the camera off. The camera will operate in the selected mode when next turned on.)
<DOWN CONVERTER> M10 (U19)	OUTPUT SIGNAL	MAIN , VF, RET
	SETTING	CAM, CCU When a CCU is connected: Either CAM (settings made with the camera) or CCU (settings taken from the linked CCU) can be selected. When CCU is selected, the values for the items shown below are displayed in parenthesis and cannot be changed with the camera. When a CCU is not connected: CCU cannot be selected.
	SD MATRIX	ON, OFF, (ON), (OFF)
	DETAIL	ON, OFF, (ON), (OFF)
	DTL LEVEL	-99 to 99 (-20)
	H DTL FREQ	-99 to 99 (-20)
	ASPECT	SQ, EC, (SQ), (EC)

Page title Page No.	Item	Settings	
<TEST OUT> M11 (U17)	OUTPUT	SD-SYNC, VF, HD-SYNC, VBS , PROMPTER2 PROMPTER2 is enabled only when an HSCU-300 is connected.	
	(PWR SAVE)	Displayed in POWER SAVE mode only	
	VBS-OUT		
	CHARACTER	ON, OFF	
	GAIN	-127 to 127 0	
	CHROMA	-127 to 127 0	
	SETUP UC model only	ON , OFF Displayed when the format is NTSC	
	HD SYNC-OUT		
	V-PHASE	-127 to 127 0	
	H-PHASE	-127 to 127 0	
<SDI OUT> M12 (U18)	OUTPUT	MAIN , VF, RET, SD-SDI, SDI-PROMPTER In SD-SDI mode, the SD signal selected for OUTPUT SIGNAL of <DOWN CONVERTER> is output. SDI-PROMPTER is enabled only when an HSCU-300 is connected.	
	(PWR SAVE)	Displayed in POWER SAVE mode only	
	CHARACTER	ON, OFF Not displayed if OUTPUT is set to VF or SDI-PROMPTER	
	EMB AUDIO	ON, OFF	
	(1-MIC1 2-MIC2) (3-AES1 4-AES2)	Displayed when OUTPUT is MAIN	
	(1-PGM1 2-PGM2) (3-ENG 4-PROD)	Displayed when OUTPUT is other than MAIN	
	<POWER SAVE> M13 (U11)	SDI OUT PWR SAVE , ACTIVE	
	DOWN CONVERTER	PWR SAVE, ACTIVE	
	PROMPTER	PWR SAVE , ACTIVE	
	<TRUNK> M14 (U20)	TRUNK ON , OFF	
<GENLOCK> M15 Items other than REFERENCE are displayed only when no CCU connected.	REFERENCE	Condition of synchronisation, display only	
	GENLOCK	DISABLE , ENABLE	
	STATUS	Display only	
	FORMAT		
	PHASE		
	V	-1024 to 1023 0	
	HD H	-1700 to 1700 0	
	SD H	-1024 to 1023 0	
	<DATE> M16	DATE/TIME	yyyy/mm/dd hh:mm

Page title Page No.	Item	Settings
<BATTERY ALARM> M17	BEFORE END	11.5 V to 17.0 V
	END	11.0 V to 11.5 V
<OTHERS 1> M18	FAN MODE	OFF, AUTO1 , AUTO2, MIN, MAX AUTO1: Normal rotation AUTO2: Slow rotation (The internal temperature may raise with the OFF setting.)
	CAM BARS	ON, OFF
	V DTL CREATION	NAM, G, R+G, Y
	DTL H/V MODE	H/V , V Only
	TEST2 MODE	3STEP , 10STEP
	WHITE SETUP MODE	AWB, A.LVL
	ALAC	AUTO , OFF With AUTO selected, the status is displayed at the right. (ACTIVE): Compensation in progress (WAIT): Waiting for completion of lens initialization (STOP): Compensation is turned off for a non- applicable lens
<OTHERS 2> M19	DATE TYPE	1 Y/Mn/D, 2 Mn/D, 3 D/M/Y 4 D/M, 5 M/D/Y , 6 M/D Y: Year Mn: Month (numeric) M: Month (character string) D: Day
	FILTER WHT MEM	ON, OFF Set to ON to use independent white memory at each CC filter position.
	F NO. DISP	CONTROL , RETURN Select the iris indication on the panel when AUTO IRIS is off: CONTROL: To display the value from the camera RETURN: To display the value returned from the lens (When AUTO IRIS is on, the value returned from the lens is always displayed.)
<EXT RETURN> M20	SD ASPECT	SQ , EC

FILE Menu

Five types of files can be used for easy adjustments of the camera; Operator, Reference, Scene, OHB, and Lens. You can store the items set with the OPERATION menu and customized USER menu in the Operator file.

For the specific items included in these files, refer to the Maintenance Manual.

Page title Page No.	Item	Settings / Default
<OPERATOR FILE> F01	READ (MS→CAM)	Execute by ENTER. To read the operator file from a "Memory Stick"
	WRITE (CAM→MS)	Execute by ENTER. To write the current settings of the operator file items to a "Memory Stick"
	PRESET	Execute by ENTER. To set the operator file items to the preset values in internal memory
	STORE PRESET FILE	Execute by ENTER. To store the current settings of the operator file items in the operator file in internal memory.
	FILE ID	Max. 16 characters Enter a comment for the operator file to be written to a "Memory Stick." <i>See "To specify a character string" on page 24.</i>
	CAM CODE	Camera code (display only)
	DATE	Date (display only)

Page title Page No.	Item	Settings / Default
<SCENE FILE> F02	1	To store and read scene files (paint data):
	2	When storing a file in camera memory, specify
	3	the number for STORE and
	4	execute by ENTER.
	5	When reading, only specify
	STORE	the number.
	STANDARD	Execute by ENTER. To read the standard paint data
	READ (MS→CAM)	Execute by ENTER. To load five scene files from a "Memory Stick" to internal memory
	WRITE (CAM→MS)	Execute by ENTER. To write five scene files in the camera's memory to a "Memory Stick"
	FILE ID	Max.16 characters Enter a comment for the scene files to be written to a "Memory Stick." <i>See "To specify a character string" on page 24.</i>
CAM CODE	Camera code (display only)	
DATE	Date (display only)	
<REFERENCE> F03	STORE FILE	Execute by ENTER. To store the current settings of the reference file items in the reference file in internal memory.
	STANDARD	Execute by ENTER. To read the standard values in the reference file in internal memory.
	ALL PRESET	Execute by ENTER. To resume the factory- preset reference file
	READ (MS→CAM)	Execute by ENTER. To load a reference file from a "Memory Stick"
	WRITE (CAM→MS)	Execute by ENTER. To write the current settings of the reference file items to a "Memory Stick"
	FILE ID	Max.16 characters Enter a comment for the reference file to be written to a "Memory Stick." <i>See "To specify a character string" on page 24.</i>
	CAM CODE	Camera code (display only)
	DATE	Date (display only)

Page title Page No.	Item	Settings / Default	
<LENS FILE> F04	STORE FILE	Execute by ENTER.	
	No.	1 to 17 1 to 16: When using a non-serial lens 17: When using a serial lens	
	NAME	Lens file name Changeable only when using a non-serial lens	
	F NO	F1.0 to F3.4 F1.7	
	CENTER MARKER	To set and store the center marker position	
	H POS	-20 to 20 0 Increasing the value moves it to the right.	
	V POS	-20 to 20 0 Increasing the value moves it downwards.	
	STORE	Execute by ENTER.	
	<OHB FILE> F05	STORE FILE	Execute by ENTER. To store the offset values of the items specific to the CCD (No repeated store operation is necessary even if the CCD is reattached.)
		<FILE CLEAR> F06	PRESET OPERATOR
	REFERENCE (ALL)	Execute by ENTER.	
	10 SEC CLEAR	ON, OFF To activate/deactivate the function to clear the current menu item. <i>See "To return a menu item to its standard value" on page 24.</i>	
	OHB WHITE SHADE (ALL)	Execute by ENTER.	
	OHB BLACK SHADE	Execute by ENTER.	
	OHB ND OFFSET	Execute by ENTER.	
	OHB MATRIX	Execute by ENTER.	
	M.S. FORMAT	Execute by ENTER. To initialize a "Memory Stick"	

DIAGNOSIS Menu

This menu is only for viewing and no setting is made using this menu.

Page title Page No.	Item	Indication
<BOARD STATUS> D01	OHB	OK, NG
	DPR	OK, NG
	CD	OK, NG
	TX	OK, NG
	SY	OK, NG
	PS	OK, NG
<PLD VERSION> D02	TG	Vx.xxIT
	AT	Vx.xx
	VDAP	Vx.xx
	VSOP	Vx.xx
	ASSIST	Vx.xx
	DEMUX	Vx.xx
	DEMAP	Vx.xx
<ROM VERSION> D03 (U22)	AT	Vx.xx
	PANEL	Vx.xx Displayed only when mounted in HDLA
<SERIAL NO.> D04	MODEL	HSC-300
	NO	Serial No.

Appendices

Precautions

Note on laser beams

Laser beams may damage the CCDs. If you shoot a scene that includes a laser beam, be careful not to let a laser beam become directed into the lens of the camera.

Do not subject to severe shocks

Damage to the case or internal components may result.

When finished using

Set the power switch to OFF.

Operation and storage environment

Store in a level place with air conditioning.

If the unit gets wet, make sure it is completely dry before storage.

Avoid use or storage in the following places:

- Extremely hot or cold places
- Places with high humidity
- Places with strong vibration
- Near strong magnetic fields
- In places where it receives much direct sunlight, or near heating equipment

Condensation

If you move the camera from a very cold place to a warm place, or use it in a damp location, condensation may form on the lens or inside the camera.

The camera has no built-in condensation indicator. If you find condensation on the body or lens, switch the camera off and wait for the condensation to disappear for about one hour.

Phenomena specific to CCD image sensors

The following phenomena that may appear in images are specific to CCD (Charge Coupled Device) image sensors. They do not indicate malfunctions.

White flecks

Although the CCD image sensors are produced with high-precision technologies, fine white flecks may be generated on the screen in rare cases, caused by cosmic rays.

This is related to the principle of CCD image sensors and is not a malfunction.

The white flecks especially tend to be seen

- when operating at a high environmental temperature
- when you have raised the master gain (sensitivity)

This product has a compensation function and the problem may be alleviated by automatic black balance adjustment (see page 16).

Smear

When an extremely bright object, such as a strong spotlight or flashlight, is being shot, vertical tails may be produced on the screen, or the image may be distorted.

Aliasing

When fine patterns, stripes, or lines are shot, they may appear jagged or flicker.

About digital triax transmission

A powerful error-correction function is incorporated for the transmission between the camera and CCU. However, if an error occurs on long-distance transmission because of external noise or for some other reason, the compensation by interpolation that partially uses the previous picture may operate.

In digital triax transmission, the following video delay in transmission may occur:

- The video delay in transmission between the camera and the CCU is approx. 9 msec to 12 msec.
- A delay of about 1 frame occurs on the viewfinder display if a camera image is sent back from the CCU to the camera as a return signal.
- The prompter video will delay approx. 5 frames in the standard mode. (For the prompter video, either the standard mode or the low-delay mode using simplified images can be selected on the CCU).
- An appropriate delay is applied to the MIC 1 and 2 audio signals from the CCU according to the video delay.
- It takes a certain time until the video signal transmitted between the camera and the CCU becomes stable after power is applied. This is not a malfunction.

About the distances of triax transmission (when an HSCU-300 is connected)

The maximum and minimum transmission distances allowed for triax cable connection are shown in the table below. The distances may vary according to the conditions, such as the total power requirements (including the power supply to the camera from the CCU) and cable degradation.

Allowable transmission range when using triax cables with the following characteristics:

Attenuation: 3.8 dB to 68.4 dB at 100 MHz (including the loss at connectors)

Cable (for example)		Max. distance ¹⁾	Min. distance
Fujikura	8.5-mm dia.	900 m (2953 ft) ²⁾	50 m (164 ft)
Fujikura	14.5-mm dia.	1800 m (5906 ft)	100 m (328 ft)
Belden 9232	13.2-mm dia	1350 m (4265 ft)	75 m (246 ft)

1) If the transmission distance exceeds approximately 7/9 of the maximum transmission distance, the teleprompter transmitted image quality starts to deteriorate.

2) The maximum distance will be 650 m (2133 ft) when the total power for the lens, viewfinder and utility outputs is between 100 and 120 W.

About the distances of triax transmission (when an HXCU-100 is connected)

The maximum and minimum transmission distances allowed for triax cable connection are shown in the table below. The distances may vary according to the conditions, such as cable degradation.

Allowable transmission range when using triax cables with the following characteristics:

Attenuation: 3.8 dB to 45.6 dB at 100 MHz (including the loss at connectors)

Cable (for example)		Max. distance	Min. distance
Fujikura	8.5-mm dia.	600 m (1969 ft)	50 m (164 ft)
Fujikura	14.5-mm dia.	1200 m (3937 ft)	100 m (328 ft)
Belden 9232	13.2-mm dia	850 m (2789 ft)	75 m (246 ft)

Error Messages

If a problem occurs during operation, a warning message is displayed.

Note

To display a message, set the DISPLAY/MENU switch to DISPLAY or MENU.

Message	Meaning
TEMP WARNING	The internal temperature is extraordinarily high.
FAN STOP	The built-in fan is not rotating properly.
SET SYSTEM CLOCK	The time/date of the internal clock have not been set.
OHB BLOCK NG!	A problem is detected in the optical block.
MSU RPN BUSY	RPN compensation was attempted using the camera menu while being operated from an external device. Consult Sony service personnel.
VF RPN BUSY	RPN compensation was attempted from an external device while being operated using the camera menu. Consult Sony service personnel.
NO MEMORY STICK	A "Memory Stick" operation was attempted with no "Memory Stick" in the slot.
MEMORY STICK ERROR	An error occurred during access to a "Memory Stick."
FORMAT ERROR!	A "Memory Stick" operation was attempted with an unformatted "Memory Stick."
MEMORY STICK LOCKED	File writing was attempted with a write-protected "Memory Stick."
FILE ERROR	An error occurred while reading a file from a "Memory Stick."
OTHER MODEL'S FILE	You attempted to read a file of other models having no compatibility.
FILE NOT FOUND	The file you attempted to read does not exist in the "Memory Stick."

Using a "Memory Stick"

When a "Memory Stick" is inserted in the camera, the file data can be stored on the "Memory Stick," which enables you to share data among cameras.

Usable types of "Memory Stick"

You can use a "Memory Stick," a "Memory Stick Duo," a "Memory Stick PRO," a "Memory Stick PRO Duo," and a "MagicGate Memory Stick" with this product. You can use a "Memory Stick Duo" or a "Memory Stick PRO Duo" without any adaptor. However, the MagicGate copyright protection¹⁾ is not valid with this product.

1) MagicGate is copyright protection technology that uses encryption technology.

Note on data read/write speed

Data read/write speed may vary depending on the combination of the "Memory Stick" and "Memory Stick" compliant product you use.

To insert a "Memory Stick"

Insert a "Memory Stick" with the label side up into the "Memory Stick" slot until it clicks and the access lamp lights in red.

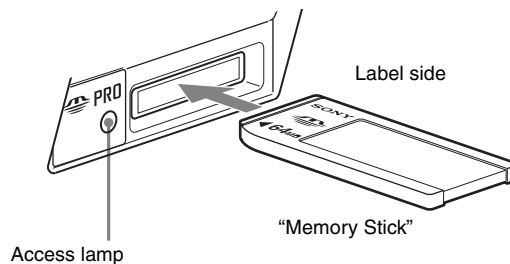

Access lamp

If the access lamp is lit or is flashing, data is being read from or written to the "Memory Stick." At this time, do not shake the product or subject it to shock. Do not turn off the power of the product or remove the "Memory Stick." This may damage the data.

About a "Memory Stick"

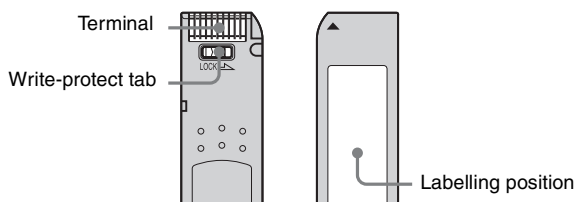

- When you set the "Memory Stick" write-protect tab to "LOCK," data cannot be recorded, edited, or erased.
- Data may be damaged if:
 - You remove the "Memory Stick" or turn off the unit while it is reading or writing data.
 - You use the "Memory Stick" in a location subject to the effects of static electricity or electric noise.

Notes

- Do not attach anything other than the supplied label to the "Memory Stick" labeling position.
- Attach the label so that it does not stick out beyond the labeling position.
- Carry and store the "Memory Stick" in its case.
- Do not touch the terminal of the "Memory Stick" with anything, including your finger or metallic objects.
- Do not strike, bend, or drop the "Memory Stick."
- Do not disassemble or modify the "Memory Stick."
- Do not allow the "Memory Stick" to get wet.
- Do not use or store the "Memory Stick" in a location that is:
 - Extremely hot, such as in a car parked in the sun
 - Under direct sunlight
 - Very humid or subject to corrosive substances

Precautions

- To prevent data loss, make backups of data frequently. In no event will Sony be liable for any loss of data.
- Unauthorized recording may be contrary to the provisions of copyright law. When you use a “Memory Stick” that has been pre-recorded, be sure that the material has been recorded in accordance with copyright and other applicable laws.
- The “Memory Stick” application software may be modified or changed by Sony without prior notice.

- “Memory Stick” and  are trademarks of Sony Corporation.
- “Memory Stick Duo” is a trademark of Sony Corporation.
- “Memory Stick PRO” and **MEMORY STICK PRO** are trademarks of Sony Corporation.
- “Memory Stick PRO Duo” is a trademark of Sony Corporation.
- “MagicGate” is a trademark of Sony Corporation.

Specifications

General	
Power requirements	180 V DC, 1.0 A (max.) 12 V DC, 7 A (max.)
Operating temperature	-20°C to +45°C (-4°F to +113°F)
Storage temperature	-20°C to +60°C (-4°F to +140°F)
Mass	Approx. 4.5 kg (9 lb 15 oz) (camera head only)
Imager	
Imager	2/3-type Progressive Scan CCD
Method	3-CCD, RGB
Effective resolution	1920 (horizontal) × 1080 (vertical)
Electrical characteristics	
Sensitivity	f10.0 with 59.94 Hz/f11.0 with 50.00 Hz (at 2000 lx with 89.9% reflectivity)
Image S/N	HD output: Typical 55 dB SD output: Typical 65 dB (59.94 Hz) Typical 63 dB (50.00 Hz)
Horizontal resolution	HD: 1000 TV lines (at center of screen) 5% or higher modulation
Geometric distortion	Negligible (not including lens distortion)
Optical system specifications	
Spectral system	F1.4 prism
Built-in filters	Color temperature conversion filters A: Cross filter B: 3200K (clear) C: 4300K D: 6300K ND filters 1: Clear 2: 1/4 ND 3: 1/16 ND 4: 1/64 ND
Input/output connectors	
CCU	Triax connector (1)
LENS	12-pin (1)
VF	20-pin (1)
MIC 1 IN	XLR 3-pin, female (1)

AUDIO IN CH1, CH2	XLR 3-pin, female (1 each) For MIC: -60 dBu (variable up to -20 dBu by menu or HSCU-300 operation), balanced For LINE: 0 dBu, balanced
INTERCOM	XLR 5-pin, female (1)
EARPHONE	Stereo minijack (1)
DC IN	XLR 4-pin (1), 10.5 to 17 V DC
DC OUT	4-pin (1), 10.5 to 17 V DC, 0.5 A maximum It may be limited depending on the load and input conditions.
SDI	BNC type (1)
TEST OUT	BNC type (1)
PROMPTER/GENLOCK/ RET IN	BNC type (1), 1 Vp-p, 75 ohms
RET CTRL	6-pin (1)
REMOTE	8-pin (1)
TRACKER	10-pin (1)

Supplied accessories	
Operation manual (1)	
CD-ROM (1)	
Cable clamp belt (1)	
Switch label (1)	
Optional accessories	
HD Electronic Viewfinder HDVF-200 (2-type, monochrome) HDVF-550 (5-type, monochrome) HDVF-C35W (3.5-type, color) HDVF-C550W (5-type, color) HDVF-C730W (6.5-type, color)	
Large Lens Adaptor HDLA1500 (large lens + large viewfinder) HDLA1505 (large lens + small viewfinder) Large Viewfinder Adaptor HDLA1507 (small lens + large viewfinder)	
Camera Hanger A-1128-405-A	
CAC-12 Microphone Holder	
CAC-6 Return Video Selector	
VCT-14 Tripod Adaptor	
“Memory Stick”	
Low-repulsion Shoulder Pad A-8286-346-A	
Shoulder Strap A-6772-374-C	
Related equipment	
Camera Control Unit HSCU-300 HXCUC-100	
MSU-1000/1500 Master Setup Unit	
RCP-1000-series Remote Control Panel	
RM-B150/B750 Remote Control Unit	

Dimensions

Unit: mm (inches)

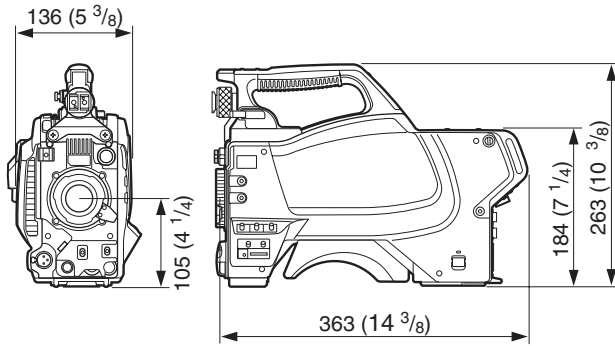

Design and specifications are subject to change without notice.

Note

Always verify that the unit is operating properly before use. SONY WILL NOT BE LIABLE FOR DAMAGES OF ANY KIND INCLUDING, BUT NOT LIMITED TO, COMPENSATION OR REIMBURSEMENT ON ACCOUNT OF THE LOSS OF PRESENT OR PROSPECTIVE PROFITS DUE TO FAILURE OF THIS UNIT, EITHER DURING THE WARRANTY PERIOD OR AFTER EXPIRATION OF THE WARRANTY, OR FOR ANY OTHER REASON WHATSOEVER.

Menu Tree

OPERATION

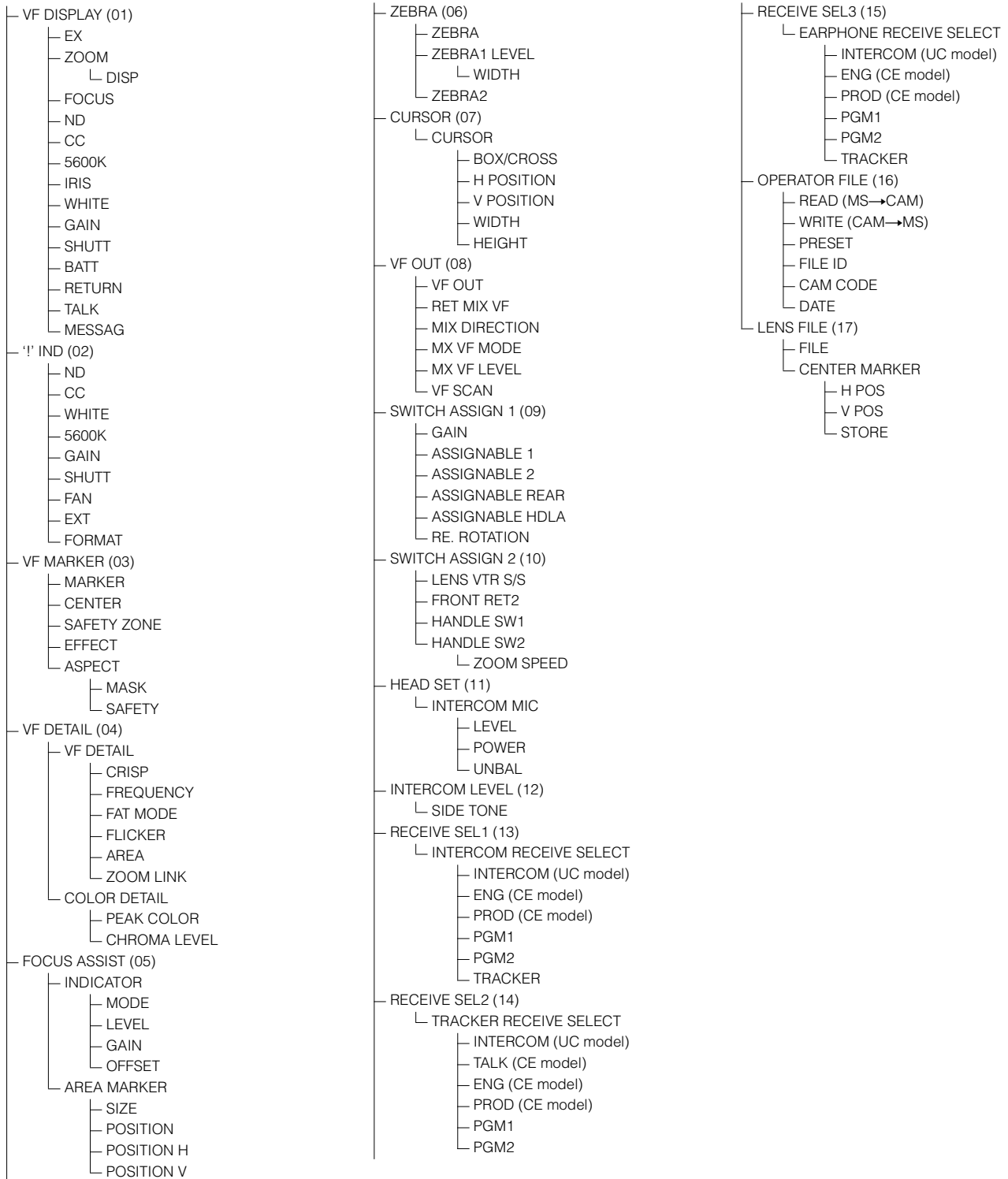

PAINT

- SW STATUS (P01)
 - FLARE
 - GAMMA
 - BLK GAM
 - KNEE
 - WHT CLIP
 - DETAIL
 - LVL DEP
 - SKIN DTL
 - MATRIX
- VIDEO LEVEL (P02)
 - WHITE
 - BLACK
 - FLARE
 - GAMMA
 - V MOD
 - FLARE
 - V MOD
 - D.SHAD
 - TEST
- COLOR TEMP (P03)
 - WHITE
 - AUTO WHITE BALANCE
 - COLOR TEMP
 - BALANCE
 - ATW
 - SPEED
 - MASTER
- GAMMA (P04)
 - LEVEL
 - COARSE
 - TABLE
 - GAMMA
 - TEST
- BLACK GAMMA (P05)
 - LEVEL
 - RANGE
 - TEST
- SATURATION (P06)
 - SATURATION
 - LOW KEY SAT
 - TEST
- KNEE (P07)
 - K POINT
 - K SLOPE
 - KNEE
 - KNEE MAX
 - KNEE SAT
 - AUTO KNEE
 - POINT LIMIT
 - SLOPE
 - ABS
- WHITE CLIP (P08)
 - W CLIP M
 - ABS
- DETAIL 1 (P09)
 - DETAIL
 - LEVEL
 - LIMITER [M]
 - LIMITER [WHT]
 - LIMITER [BLK]
 - CRISP
 - LVL DEP
 - ABS
- DETAIL 2 (P10)
 - H/V RATIO
 - FREQ
 - MIX RATIO
 - KNEE APT
 - ABS
- SKIN DETAIL (P11)
 - SKIN DTL
 - SKIN GATE
 - AUTO HUE
 - PHASE
 - WIDTH
 - SAT
 - LEVEL
 - ABS
- USER MATRIX (P12)
 - R-G
 - R-B
 - G-R
 - G-B
 - B-R
 - B-G
 - MATRIX
 - PRESET
 - USER
 - MULTI
- MULTI MATRIX (P13)
 - PHASE
 - HUE
 - SAT
 - ALL CLEAR
 - GATE
 - MATRIX
 - PRESET
 - USER
 - MULTI
- SHUTTER (P14)
 - SHUTTER
 - ECS FREQ
- SCENE FILE (P15)
 - 1/2/3/4/5
 - STORE
 - STANDARD
 - READ (MS→CAM)
 - WRITE (CAM→MS)
 - FILE ID
 - CAM CODE
 - DATE

MAINTENANCE

- AUTO SETUP (M01)
 - AUTO BLACK
 - AUTO WHITE
 - AUTO LEVEL
 - AUTO WHITE SHADING
 - AUTO BLACK SHADING
 - TEST
- WHITE SHADING (M02)
 - V SAW
 - V PARA
 - H SAW
 - H PARA
 - WHITE
 - AUTO WHITE SHADING
 - WHITE SHAD MODE
- BLACK SHADING (M03)
 - V SAW
 - V PARA
 - H SAW
 - H PARA
 - BLK SET
 - BLACK
 - MASTER GAIN
 - AUTO BLACK SHADING
- OHB MATRIX (M04)
 - PHASE
 - HUE
 - SAT
 - ALL CLEAR
 - OHB MATRIX
 - MATRIX
- AUTO IRIS (M05)
 - AUTO IRIS
 - WINDOW
 - OVERRIDE
 - IRIS LEVEL
 - APL RATIO
 - IRIS GAIN
 - IRIS CLOSE
- MIC GAIN (M06)
 - MIC1
 - MIC2
 - FRONT MIC +48V
- UP TALLY (M07)
 - TALLY BRIGHTNESS
 - NUMBER BRIGHTNESS
 - CAMERA NUMBER
 - NUMBER DISPLAY
- CALL/TALLY (M08)
 - CCU CALL
 - CAM CALL
- OUTPUT FORMAT (M09)
 - CURRENT
 - ACTIVE LINE
- DOWN CONVERTER (M10)
 - OUTPUT SIGNAL
 - SETTING
 - SD MATRIX
 - DETAIL
 - DTL LEVEL
 - H DTL FREQ
 - ASPECT

- TEST OUT (M11)
 - OUTPUT
 - └ (PWR SAVE)
 - VBS-OUT
 - CHARACTER
 - GAIN
 - CHROMA
 - SETUP (UC model)
 - HD SYNC-OUT
 - V-PHASE
 - H-PHASE
- SDI OUT (M12)
 - OUTPUT
 - └ (PWR SAVE)
 - CHARACTER
 - EMB AUDIO
 - (1-MIC1 2-MIC2)/(3-AES1 4-AES2)
 - (1-PGM1 2-PGM2)/(3-ENG 4-PROD)
- POWER SAVE (M13)
 - SDI OUT
 - DOWN CONVERTER
 - PROMPTER
- TRUNK (M14)
 - TRUNK
- GENLOCK (M15)
 - REFERENCE
 - GENLOCK
 - STATUS
 - FORMAT
 - PHASE
 - V
 - HD H
 - SD H
- DATE (M16)
 - DATE/TIME
- BATTERY ALARM (M17)
 - BEFORE END
 - END
- OTHERS 1 (M18)
 - FAN MODE
 - CAM BARS
 - V DTL CREATION
 - DTL H/V MODE
 - TEST2 MODE
 - WHITE SETUP MODE
 - ALAC
- OTHERS 2 (M19)
 - DATE TYPE
 - FILTER WHT MEM
 - F NO. DISP
- EXT RETURN (M20)
 - SD ASPECT

FILE

- OPERATOR FILE (F01)
 - READ (MS→CAM)
 - WRITE (CAM→MS)
 - PRESET
 - STORE PRESET FILE
 - FILE ID
 - CAM CODE
 - DATE
- SCENE FILE (F02)
 - 1/2/3/4/5
 - STORE
 - STANDARD
 - READ (MS→CAM)
 - WRITE (CAM→MS)
 - FILE ID
 - CAM CODE
 - DATE
- REFERENCE (F03)
 - STORE FILE
 - STANDARD
 - └ ALL PRESET
 - READ (MS→CAM)
 - WRITE (CAM→MS)
 - FILE ID
 - CAM CODE
 - DATE
- LENS FILE (F04)
 - STORE FILE
 - No.
 - NAME
 - F NO
 - CENTER MARKER
 - H POS
 - V POS
 - STORE
- OHB FILE (F05)
 - STORE FILE
- FILE CLEAR (F06)
 - PRESET OPERATOR
 - REFERENCE (ALL)
 - └ 10 SEC CLEAR
 - OHB WHITE SHADE (ALL)
 - OHB BLACK SHADE
 - OHB ND OFFSET
 - OHB MATRIX
 - M.S. FORMAT

DIAGNOSIS

- BOARD STATUS (D01)
 - OHB
 - DPR
 - CD
 - TX
 - SY
 - PS
- PLD VERSION (D02)
 - TG
 - AT
 - VDAP
 - VSOP
 - ASSIST
 - DEMUX
 - DEMAP
- ROM VERSION (D03)
 - AT
 - PANEL
- SERIAL NO. (D04)
 - MODEL
 - NO

The material contained in this manual consists of information that is the property of Sony Corporation and is intended solely for use by the purchasers of the equipment described in this manual.

Sony Corporation expressly prohibits the duplication of any portion of this manual or the use thereof for any purpose other than the operation or maintenance of the equipment described in this manual without the express written permission of Sony Corporation.

Sony Corporation

HSC-300 (UC/CE)
4-137-698-02(1)

<http://www.sony.net/>

© 2009