

# **CARBONITE**

## **Carbonite Black User Manual**

**v15.0**

---

# Thank You For Choosing Ross

You've made a great choice. We expect you will be very happy with your purchase of Ross Technology.

Our mission is to:

1. Provide a Superior Customer Experience
  - offer the best product quality and support
2. Make Cool Practical Technology
  - develop great products that customers love

Ross has become well known for the Ross Video Code of Ethics. It guides our interactions and empowers our employees. I hope you enjoy reading it below.

If anything at all with your Ross experience does not live up to your expectations be sure to reach out to us at [solutions@rossvideo.com](mailto:solutions@rossvideo.com).



David Ross  
CEO, Ross Video  
[dross@rossvideo.com](mailto:dross@rossvideo.com)

## Ross Video Code of Ethics

Any company is the sum total of the people that make things happen. At Ross, our employees are a special group. Our employees truly care about doing a great job and delivering a high quality customer experience every day. This code of ethics hangs on the wall of all Ross Video locations to guide our behavior:

1. We will always act in our customers' best interest.
2. We will do our best to understand our customers' requirements.
3. We will not ship crap.
4. We will be great to work with.
5. We will do something extra for our customers, as an apology, when something big goes wrong and it's our fault.
6. We will keep our promises.
7. We will treat the competition with respect.

8. We will cooperate with and help other friendly companies.
9. We will go above and beyond in times of crisis. *If there's no one to authorize the required action in times of company or customer crisis - do what you know in your heart is right. (You may rent helicopters if necessary.)*

## Document Information

- Ross Part Number: **4804DR-110-15.0**
- Release Date: November, 2020. Printed in Canada
- Equipment: This document applies to all Carbonite Black frames and control panels.

## Copyright

©2020 Ross Video Limited, Ross<sup>®</sup>, MiniME<sup>™</sup>, and any related marks are trademarks or registered trademarks of Ross Video Limited. All other trademarks are the property of their respective companies. PATENTS ISSUED and PENDING. All rights reserved. No part of this publication may be reproduced, stored in a retrieval system, or transmitted in any form or by any means, mechanical, photocopying, recording or otherwise, without the prior written permission of Ross Video. While every precaution has been taken in the preparation of this document, Ross Video assumes no responsibility for errors or omissions. Neither is any liability assumed for damages resulting from the use of the information contained herein.

Microsoft<sup>®</sup>, Windows<sup>®</sup>, and Windows XP<sup>®</sup> are either registered trademarks or trademarks of Microsoft Corporation in the United States and/or other countries.

Macintosh<sup>®</sup>, and OS X<sup>®</sup> are trademarks of Apple Inc., registered in the U.S. and other countries.

Google Chrome<sup>™</sup>, Google<sup>®</sup>, and the Google logo are registered trademarks of Google Inc.

## Patents

Patent numbers US 7,034,886; US 7,508,455; US 7,602,446; US 7,802,802 B2; US 7,834,886; US 7,914,332; US 8,307,284; US 8,407,374 B2; US 8,499,019 B2; US 8,519,949 B2; US 8,743,292 B2; US D752,530 S; GB 2,419,119 B; GB 2,447,380 B; and other patents pending.

## Important Regulatory and Safety Notices to Service Personnel

Before using this product and any associated equipment, refer to the “**Important Safety Instructions**” listed in the front of this manual to avoid personnel injury and to prevent product damage.

Product may require specific equipment, and/or installation procedures to be carried out to satisfy certain regulatory compliance requirements. Notices have been included in this publication to call attention to these specific requirements.

## Symbol Meanings



**Protective Earth:** This symbol identifies a Protective Earth (PE) terminal, which is provided for connection of the supply system's protective earth (green or green/yellow) conductor.



**Important:** This symbol on the equipment refers you to important operating and maintenance (servicing) instructions within the Product Manual Documentation. Failure to heed this information may present a major risk of damage or injury to persons or equipment.



**Warning:** The symbol with the word “Warning” within the equipment manual indicates a potentially hazardous situation which, if not avoided, could result in death or serious injury.



**CAUTION:** The symbol with the word “Caution” within the equipment manual indicates a potentially hazardous situation which, if not avoided, may result in minor or moderate injury. It may also be used to alert against unsafe practices.



**Warning Hazardous Voltages:** This symbol is intended to alert the user to the presence of uninsulated “dangerous voltage” within the product enclosure that may be of sufficient magnitude to constitute a risk of shock to persons.



**ESD Susceptibility:** This symbol is used to alert the user that an electrical or electronic device or assembly is susceptible to damage from an ESD event.

## Important Safety Instructions

1.  **Warning:** Read these instructions.
2. Keep these instructions.
3. Heed all warnings.
4. Follow all instructions.
5. Do not use this apparatus near water.
6. Clean only with a dry cloth.
7. Do not block any ventilation openings. Install in accordance with manufacturer's instructions.
8. Do not install near heat sources such as radiators, heat registers, stoves, or other apparatus (including amplifiers) that produce heat.

9. Do not defeat the safety purpose of the polarized or grounding-type plug. A polarized plug has two blades with one wider than the other. A grounding type plug has two blades and a third grounding prong. The third prong is provided for your safety. If the provided plug does not fit into your outlet, consult an electrician for replacement of the obsolete outlet.

10. Protect the power cord from being walked on or pinched, particularly at plugs, convenience receptacles, and the point where they exit from the apparatus.

11. Only use attachments/accessories specified by the manufacturer.

12. Unplug this apparatus during lightning storms or when unused for long periods of time.

13. Refer all servicing to qualified service personnel. Servicing is required when the apparatus has been damaged in any way, such as when the power-supply cord or plug is damaged, liquid has been spilled or objects have fallen into the apparatus, the apparatus has been exposed to rain or moisture, does not operate normally, or has been dropped.

14. Do not expose this apparatus to dripping or splashing, and ensure that no objects filled with liquids, such as vases, are placed on the apparatus.

15. To completely disconnect this apparatus from the AC Mains, disconnect the power supply cord plug from the AC receptacle.

16. The mains plug of the power supply cord shall remain readily operable.

17.  **Warning:** Indoor Use: To reduce the risk of fire or electric shock, do not expose this apparatus to rain or moisture.

18. The safe operation of this product requires that a protective earth connection be provided. A grounding conductor in the equipment's supply cord provides this protective earth. To reduce the risk of electrical shock to the operator and service personnel, this ground conductor must be connected to an earthed ground.

19.  **Warning:** This apparatus, when equipped with multiple power supplies, can generate high leakage currents. To reduce the risk of electric shock, ensure that each individual supply cord

is connected to its own separate branch circuit with an earth connection.

20.  **CAUTION:** These service instructions are for use by qualified service personnel only. To reduce the risk of electric shock, do not perform any servicing other than that contained in the operating instructions unless you are qualified to do so.

21. Service barriers within this product are intended to protect the operator and service personnel from hazardous voltages. For continued safety, replace all barriers after servicing.

22. Certain parts of this equipment still present a safety hazard with the power switch in the OFF position. To avoid electrical shock, disconnect all A/C power cords from the chassis' rear appliance connectors before servicing.

23. This product contains safety critical parts, which, if incorrectly replaced, may present a risk of fire or electrical shock. Components contained within the product's power supplies and power supply area are not intended to be customer-serviced and should be returned to the factory for repair.

24. To reduce the risk of fire, replacement fuses must be the same type and rating.

25. Use only power cords specified for this product and certified for the country of use.

26. The safe operation of this equipment requires that the user heed and adhere to all installation and servicing instruction contained within the equipment's Setup Manuals.

27.  **Warning:** This product includes an "Ethernet Port" which allows this product to be connected to a local area network (LAN). Only connect to networks that remain inside the building. Do not connect to networks that go outside the building.

28.  **CAUTION:** This apparatus contains a Lithium battery, which if replaced incorrectly, or with an incorrect type, may cause an explosion. Replace only with a CR2032 coin type lithium battery. Dispose of used batteries according to the manufacturer's instruction by qualified service personnel.

29. For use at altitude 2000m or lower.

30. For use in non-tropical locations.

31.  **CAUTION:** Do not make mechanical or electrical modifications to the equipment or add metallic

items, such as metallic foil labels, to the printed circuit boards. Modifications can impair regulatory compliance, or performance and may void your warranty.

## EMC Notices

### United States of America — FCC Part 15

This equipment has been tested and found to comply with the limits for a class A Digital device, pursuant to part 15 of the FCC Rules. These limits are designed to provide reasonable protection against harmful interference when the equipment is operated in a commercial environment. This equipment generates, uses, and can radiate radio frequency energy and, if not installed and used in accordance with the instruction manual, may cause harmful interference to radio communications. Operation of this equipment in a residential area is likely to cause harmful interference in which case the user will be required to correct the interference at his own expense.



**Important:** Changes or modifications to this equipment not expressly approved by Ross Video Limited could void the user's authority to operate this equipment.

### Canada

This Class “A” digital apparatus complies with Canadian ICES-003.

Cet appareil numérique de la classe “A” est conforme a la norme NMB-003 du Canada.

### Korea — Class A Statement

이 기기는 업무용 환경에서 사용할 목적으로 적합성 평가를 받은 기기로서 가정용 환경에서 사용하는 경우 전파간섭의 우려가 있습니다.

This device has been evaluated for conformity for use in a business environment. When used in a home environment, there is a danger of interference.

### Europe

This equipment is in compliance with the essential requirements and other relevant provisions of **CE Directive 93/68/EEC**.

### International

This equipment has been tested to **CISPR 22:1997** along with amendments **A1:2000** and

**A2:2002**, and found to comply with the limits for a Class A Digital device.



**Important:** This is a Class A product. In domestic environments, this product may cause radio interference, in which case the user may have to take adequate measures.

## General Handling Guidelines

- Careful handling, using proper ESD precautions, must be observed.
- Power down the system before PCB removal.

## A Word About Static Discharge

Throughout the many procedures in this manual, please observe all static discharge precautions.



**CAUTION:** Avoid handling the switcher circuit boards in high static environments such as carpeted areas, and when synthetic fiber clothing is worn. Touch the frame to dissipate static charge before removing boards from the frame, and exercise proper grounding precautions when working on circuit boards. Exercise proper grounding precautions when working on circuit boards.

## Warranty and Repair Policy

Ross Video Limited (Ross) warrants its switchers and related options, to be free from defects under normal use and service for a period of ONE YEAR from the date of shipment. Fader handle assemblies are warranted for the life of the product. If an item becomes defective within the warranty period Ross will repair or replace the defective item, as determined solely by Ross.

Warranty repairs will be conducted at Ross, with all shipping FOB Ross dock. If repairs are conducted at the customer site, reasonable out-of-pocket charges will apply. At the discretion of Ross, and on a temporary loan basis, plug in circuit boards or other replacement parts may be supplied free of charge while defective items undergo repair. Return packing, shipping, and special handling costs are the responsibility of the customer.

Software upgrades for switchers may occur from time to time, and are determined by Ross Video. The upgrades are posted on the Ross Video website, and are free of charge for the life of the switcher.

This warranty is void if products are subjected to misuse, neglect, accident, improper

installation or application, or unauthorized modification.

In no event shall Ross Video Limited be liable for direct, indirect, special, incidental, or consequential damages (including loss of profit). Implied warranties, including that of merchantability and fitness for a particular purpose, are expressly limited to the duration of this warranty.

This warranty is TRANSFERABLE to subsequent owners, subject to Ross Video's notification of change of ownership.

## Environmental Information

### Waste Electrical and Electronic Equipment Directive (WEEE Directive)

**The equipment that you purchased required the extraction and use of natural resources for its production. It may contain hazardous substances that could impact health and the environment.**

To avoid the potential release of those substances into the environment and to diminish the need for the extraction of natural resources, Ross Video encourages you to use the appropriate take-back systems. These systems will reuse or recycle most of the materials from your end-of-life equipment in an environmentally friendly and health conscious manner.

The crossed-out wheeled bin symbol invites you to use these systems.



If you need more information on the collection, reuse, and recycling systems, please contact your local or regional waste administration.

You can also contact Ross Video for more information on the environmental performances of our products.

### Use of Hazardous Substances in Electrical and Electronic Products (China RoHS)

Ross Video Limited has reviewed all components and processes for compliance to:

“ Management Methods for the Restriction of the Use of Hazardous Substances in Electrical and Electronic Products ” also known as China RoHS.

The “ Environmentally Friendly Use Period ” (EFUP) and Hazardous Substance Tables have been established for all products. We are currently updating all of our Product Manuals.

The Hazardous substances tables are available on our website at: <http://www.rossvideo.com/about-ross/company-profile/green-practices/china-rohs.html>

### 电器电子产品中有毒物质的使用

Ross Video Limited 按照以下的标准对所有组件和流程进行了审查:

"电器电子产品有害物质限制使用管理办法" 也被称为中国RoHS。

所有产品都具有 "环保使用期限" (EFUP) 和有害物质表。目前, 我们正在更新我们所有的产品手册。

有害物质表在我们的网站:

<http://www.rossvideo.com/about-ross/company-profile/green-practices/china-rohs.html>

## Company Address

**Ross Video Limited** — 8 John Street Iroquois, Ontario, Canada, K0E 1K0

**Ross Video Incorporated** — P.O. Box 880, Ogdensburg, New York, USA, 13669-0880

General Business Office: (+1)613-652-4886

Fax: (+1)613-652-4425

Toll Free Technical Support (North America): 1-844-652-0645

Toll Free Technical Support (International): +800 1005 0100

Technical Support: (+1)613-652-4886

After Hours Emergency: (+1)613-349-0006

E-Mail (Support): [techsupport@rossvideo.com](mailto:techsupport@rossvideo.com)

E-Mail (General): [solutions@rossvideo.com](mailto:solutions@rossvideo.com)

Website: [www.rossvideo.com](http://www.rossvideo.com)



---

## Technical Support

At Ross Video, we take pride in the quality of our products, but if a problem does occur, help is as close as the nearest telephone.

Our 24-Hour Hot Line service ensures you have access to technical expertise around the clock. After-sales service and technical support are provided directly by Ross Video personnel. During business hours (eastern standard time), technical support personnel are available by telephone. Outside of normal business hours and on weekends, a direct emergency technical support phone line is available. If the technical support personnel who is on call does not answer this line immediately, a voice message can be left and the call will be returned shortly. Our Technical support staff are available to react to any problem and to do whatever is necessary to ensure customer satisfaction.

## Supporting Documentation

Ross Video provides a wide variety of helpful documentation for the setup and support of your equipment. Most of this documentation can be found either on the Product Resources disk that came with your equipment, on the Ross Video website ([www.rossvideo.com](http://www.rossvideo.com)), or on the Ross Video Community site ([discussions.rossvideo.com/](http://discussions.rossvideo.com/))

- **Carbonite Online Help for DashBoard** — visit [help.rossvideo.com/carbonite](http://help.rossvideo.com/carbonite)
- **Operation Manual (4804DR-110)** — operational instructions for all Carbonite Black switchers
- **Setup Manual (4804DR-120)** — setup and configuration instructions for Carbonite Black and Carbonite Black+ frames
- **Carbonite Black QuickStart Poster (4804DR-200)** — setup information and specifications for the Carbonite Black and Carbonite Black+ frames
- **Upgrade Notes (4802DR-500)** — upgrade instructions, new features, and known issues for a given software version
- **Software Licenses (4802DR-502)** — third-party software licences
- **Carbonite Multilingual Safety Information (4802DR-503)** — translated product safety information
- **Carbonite Frame Fan Replacement (4802DR-300)** — instructions for replacing cooling fans in the Carbonite, Carbonite+,

Carbonite MultiMedia, Carbonite Black, or Carbonite Black+ frames

- **Carbonite Frame RAM Replacement (4802DR-301)** — instructions for replacing the RAM in the Carbonite, Carbonite+, or Carbonite MultiMedia frames
- **Control Panel Desk Mounting (4802DR-302)** — desk mounting instructions for Carbonite control panel
- **SideBox Installation (4802DR-304)** — installation and mounting instruction for SideBox module
- **Auxiliary Control Panel Installation (4802DR-305)** — installation and mounting instruction for remote aux panel (CPS-AUX-053B)
- **GVG100 Supported Command (4802DR-401)** — connection and GVG100 commands supported by the switcher
- **RossTalk Commands (4802DR-403)** — supported commands using RossTalk protocol
- **Device Setup Sheets (4802DR-6xx)** — setup information for controlling external devices from the switcher
- **Robotic Camera Control (4802DR-131)** — overview of the operational interface when controlling a robotic camera from the switcher
- **Audio Mixer Control (4802DR-132)** — overview of the operational interface when controlling an audio mixer from the switcher
- **Video Server Control (4802DR-133)** — overview of the operational interface when controlling a video server from the switcher
- **Configuration Guide (4804DR-100)** — product description and marketing codes for switchers and options
- **CarboNET Installation (4805DR-100)** — installation instructions for the Carbonite PMC translator.

# Contents

## Features.....12

|  |    |
|--|----|
| Clean Feed Output.....                 | 12 |
| Custom Controls.....                   | 12 |
| Device Control.....                    | 12 |
| DVE (Fly Key).....                     | 12 |
| Effects Dissolve.....                  | 12 |
| General Purpose Interface (GPI).....   | 12 |
| LiveEDL.....                           | 12 |
| Matte/Wash Generator.....              | 12 |
| ME Effect System.....                  | 13 |
| Media-Store.....                       | 13 |
| MediaManager.....                      | 13 |
| MediaWipe.....                         | 13 |
| MemoryAI Recall Mode.....              | 13 |
| Memory System.....                     | 13 |
| MiniME™.....                           | 13 |
| MultiScreen.....                       | 13 |
| MultiViewer.....                       | 13 |
| OverDrive® Caprica Support.....        | 14 |
| Pattern and Matte/Wash Generators..... | 14 |
| Tally Outputs.....                     | 14 |
| UltraChrome.....                       | 14 |
| XPression Live CG.....                 | 14 |

## Dashboard.....15

|                                   |    |
|-----------------------------------|----|
| Switcher Status in Dashboard..... | 15 |
| Configuration.....                | 15 |
| Live Assist.....                  | 15 |
| PanelINK.....                     | 15 |
| Custom Controls.....              | 15 |
| ViewControl.....                  | 15 |
| MediaManager.....                 | 16 |
| Personality.....                  | 16 |
| Help.....                         | 16 |

## SoftPanel.....17

|                   |    |
|-------------------|----|
| Menu Area.....    | 17 |
| User Area.....    | 17 |
| Control Area..... | 17 |
| Bus Area.....     | 18 |

## Audio and Video Processing.....19

|                                |    |
|--------------------------------|----|
| Video Processing and Flow..... | 19 |
|--------------------------------|----|

## Video Sources.....20

|   |    |
|---|----|
| To Select a Source on a Bus from Dashboard..... | 20 |
|---|----|

## Video Layering.....21

|                        |    |
|------------------------|----|
| Re-Entry.....          | 21 |
| Re-Entry Timing.....   | 21 |
| To Re-Enter an ME..... | 21 |

|                            |    |
|----------------------------|----|
| FlexiClean Clean Feed..... | 22 |
|----------------------------|----|

## Video Preview.....23

|                  |    |
|------------------|----|
| MultiViewer..... | 23 |
|------------------|----|

## Matte Source.....24

|                              |    |
|------------------------------|----|
| To Set Up a Matte Color..... | 24 |
| To Set Up a Wash.....        | 24 |

## Copying.....25

|                            |    |
|----------------------------|----|
| ME Copy.....               | 25 |
| To Copy an ME.....         | 25 |
| Key Copy.....              | 25 |
| To Copy a Key.....         | 25 |
| Key Swap.....              | 25 |
| To Perform a Key Swap..... | 25 |

## Transitions.....26

|  |    |
|--|----|
| Performing Transitions.....                                    | 26 |
| To Perform a Transition.....                                   | 26 |
| To Perform a Transition on TouchDrive<br>(Memory Area).....    | 28 |
| To Perform a Transition on TouchDrive (No<br>Memory Area)..... | 29 |
| To Perform a Transition on Carbonite<br>Black.....             | 30 |
| Cut Transitions.....   | 31 |
| Dissolve Transitions.....                                      | 31 |
| To Set Up a Dissolve.....                                      | 31 |
| WhiteFlash.....  | 31 |
| To Set Up a WhiteFlash.....                                    | 31 |
| Wipe Transitions.....  | 32 |
| To Set Up a Wipe.....  | 32 |
| DVE Transitions.....   | 32 |
| To Set Up a DVE Transition.....                                | 32 |
| MediaWipe Transitions.....                                     | 33 |
| To Set Up a MediaWipe.....                                     | 33 |

## Keying.....35

|  |    |
|--|----|
| Self Keys.....                                       | 35 |
| To Set Up a Self Key.....                            | 35 |
| Auto Select Keys.....                                | 35 |
| To Set Up an Auto Select Key.....                    | 35 |
| UltraChrome Chroma Key.....                          | 36 |
| Chroma Key Modes.....                                | 36 |
| Chroma Key Basic Mode.....                           | 36 |
| Chroma Key Advanced Mode.....                        | 37 |
| MiniME™ Chroma Key Output.....                       | 40 |
| DVE Keys.....  | 40 |
| To Set Up a DVE Key.....                             | 41 |
| To Apply a DVE to a Key (Fly Key).....               | 41 |
| To Apply a Border/Edge Softness to a DVE<br>Key..... | 41 |
| Show Alpha.....                                      | 42 |
| Masks.....   | 42 |
| To Pattern Mask a Key.....                           | 42 |



|  |           |  |           |
|--|-----------|--|-----------|
| To Box Mask a Key.....                               | 43        | Reference and Video Mode Setup.....                | 60        |
| Split Keys.....                                      | 43        | To Set a Video Mode.....                           | 60        |
| To Set Up a Split Key.....                           | 43        | Output Reference Synchronizers.....                | 61        |
|  |           | To Set Up an Output Reference Sync.....            | 61        |
| <b>Memory Functions.....</b>                         | <b>44</b> | Switching Field.....                               | 61        |
| Storing Memories.....                                | 44        | To Set the Switching Field.....                    | 61        |
| To Store a Memory.....                               | 44        |  |           |
| Recalling Memories.....                              | 44        |  |           |
| Memory Attribute Color Coding.....                   | 45        |  |           |
| To Recall a Memory.....                              | 45        |  |           |
| Memory Attributes.....                               | 46        |  |           |
| To Set the Memory Attributes.....                    | 46        |  |           |
| Deleting a Memory.....                               | 47        |  |           |
| To Delete a Memory.....                              | 47        |  |           |
| Memory Names and Mnemonics (TouchDrive<br>only)..... | 47        |  |           |
| To Assign a Name to a Memory.....                    | 47        |  |           |
|  |           |  |           |
| <b>Switcher Sets.....</b>                            | <b>49</b> | <b>Switcher Modes.....</b>                         | <b>62</b> |
| To Store a Set.....                                  | 49        | To Set the Switcher Mode.....                      | 62        |
| To Load a Set.....                                   | 49        |  |           |
|  |           |  |           |
| <b>Media-Store.....</b>                              | <b>51</b> | <b>Video Inputs.....</b>                           | <b>63</b> |
| Working With Media-Store Animations.....             | 51        | Video Input Setup.....                             | 63        |
| Working With Media-Store Audio.....                  | 51        | To Set up an External Video Input.....             | 63        |
| Media-Store File Specifications.....                 | 52        | To Set up an Internal Video Input.....             | 63        |
| Loading Stills or Animations.....                    | 52        | Video Input Format Type.....                       | 64        |
| To Load a Media Item.....                            | 52        | To Configure The Input Format Type.....            | 64        |
| MediaManager Channel Control.....                    | 52        | Source Names.....                                  | 64        |
| Media-Store Attributes.....                          | 53        | To Set Up a Source Name.....                       | 64        |
| Media-Store Capture.....                             | 53        | To Assign a TSL ID to a Video Input.....           | 64        |
| To Capture a Still From the Panel.....               | 53        | Mnemonics.....                                     | 65        |
|  |           | To Customize Mnemonics for<br>TouchDrive.....      | 65        |
|  |           | To Customize Mnemonics for Carbonite<br>Black..... | 65        |
|  |           | Auto Key Setup.....                                | 66        |
|  |           | To Set Up an Auto Key Association.....             | 66        |
|  |           | GPI Device Control.....                            | 66        |
|  |           | To Assign a GPI to a Video Source.....             | 66        |
|  |           | Tallies Setup.....                                 | 67        |
|  |           | To Assign a Tally to an Input.....                 | 67        |
|  |           | Custom Page Auto Follow.....                       | 67        |
|  |           | To Assign a Page to a Custom Page<br>Button.....   | 67        |
|  |           | To Assign a Custom Page to Follow an<br>Input..... | 68        |
|  |           | Substitution Table.....                            | 68        |
|  |           | To Set Up a Pre-Tiled Source.....                  | 68        |
|  |           |  |           |
|  |           |  |           |
|  |           |  |           |
|  |           |  |           |
| <b>Custom Controls.....</b>                          | <b>55</b> | <b>Video Outputs.....</b>                          | <b>69</b> |
| Recording/Editing Custom Controls.....               | 55        | Video Output Setup.....                            | 69        |
| To Record a Custom Control.....                      | 55        | To Set up a Video Output.....                      | 69        |
| To Edit a Custom Control.....                        | 55        | Ancillary Data.....                                | 70        |
| Running a Custom Control.....                        | 56        | To Strip or Pass Ancillary Data.....               | 70        |
| To Run a Custom Control.....                         | 56        | FlexiClean Clean Feed.....                         | 71        |
| Naming Custom Controls.....                          | 56        | To Set Up Clean Feed.....                          | 71        |
| To Name a Custom Control.....                        | 56        | External Layer Mode.....                           | 71        |
| Deleting Custom Controls.....                        | 57        | To Set Up Layer Mode.....                          | 71        |
| To Delete a Custom Control.....                      | 57        | ME Follows.....                                    | 71        |
| Copying and Pasting Custom Controls.....             | 57        | To Set Up an ME Follow.....                        | 72        |
| To Copy and Paste a Custom Control.....              | 57        | On-Air Setting.....                                | 72        |
|  |           | To Set the On-Air Status for an Output.....        | 72        |
|  |           |  |           |
|  |           |  |           |
|  |           |  |           |
|  |           |  |           |
|  |           |  |           |
| <b>Network Connections.....</b>                      | <b>58</b> |  |           |
| Network Setup.....                                   | 58        | <b>MultiViewer.....</b>                            | <b>73</b> |
| To Connect DashBoard to the Frame.....               | 58        | MultiViewer Output Formats.....                    | 73        |
| To Change the IP Address.....                        | 58        | To Set Up a MultiViewer.....                       | 73        |
| FTP Connection.....                                  | 59        | To Set Up a MultiViewer Clock.....                 | 74        |
| To Create an FTP Connection.....                     | 59        |  |           |
|  |           |  |           |
|  |           |  |           |
| <b>Video Reference.....</b>                          | <b>60</b> |  |           |
| Supported Reference Formats.....                     | 60        |  |           |

---

## MultiScreen / MiniME™ .....76

- MiniME™ Assignment.....76
- To Set Up a MultiScreen.....76

## Frame Sync and Format Conversion.....78

- Supported FSFC Video Formats.....78
- To Set Up an Input FSFC.....79
- Aspect Ratio Conversion.....79
  - Full.....79
  - Zoom.....80
  - Letterbox.....80
  - Pillarbox.....80
  - To Set an Aspect Ratio for 480i/576i.....80

## System Real-Time Clock/Date.....81

- To Set the System Real-Time Time and Date.....81

## AES Audio Output.....82

- To Assign Audio to an AES Output.....82

## Color Correction (Carbonite Black+ Only).....83

- Proc Amp Color Correction.....83
  - To Apply a Proc Amp to a Video Source.....83
- RGB Color Correction .....83
  - To Apply a RGB Color Correction to a Video Source.....83

## Personality.....85

- Personality Settings.....85
  - General Settings.....85
  - Transition Settings.....86
- Color Schemes.....86
  - To Select a Color Scheme.....86
  - To Create a Custom Color Scheme.....87
- Bus Maps.....87
  - To Create a Bus Map.....87
- User Buttons.....87
  - To Set A User Button.....88

## GPI Control.....89

- GPI Trigger Types.....89
- GPI Setup.....89
  - To Set Up a GPI Input.....89
  - To Set Up a GPI Output.....90
- GPI Output Triggers.....90
  - To Assign a GPI Output to a Video Source.....90

## Live Edit Decision Lists (LiveEDL).....92

- LiveEDL Setup.....92
  - To Set the LiveEDL Behavior.....92
- Timecode Setup.....92
  - To Confirm External LTC Signal.....92
  - To Set Up Communications with a TSC-9902.....92
  - To Set the LTC Timecode Source.....93
- LiveEDL Data Capture.....93
  - To Start Capturing EDL Data.....93
  - To Stop Capturing and Save EDL Data.....93

## ViewControl (HD Only).....95

- ViewControl Overview.....95
  - Custom Control Buttons.....95
  - Bus Selection Buttons.....95
  - Keyer Transition Buttons.....95
  - Transition Buttons.....95
- Custom Control Button Setup.....95
  - To Set up the Custom Control Buttons.....96
- Connecting ViewControl.....96
  - To Set Up the MultiViewer for ViewControl.....96

## MultiPanel.....98

- To Set Up MultiPanel Permissions.....98

## Diagnostics.....99

- Switcher Status.....99
- Switcher Logs.....99
  - To Copy Logs To a USB.....99
- Diagnostics.....99
  - Frame DIP Switches.....99
    - To Run the Tally Test.....100
    - To Run the GPI Input Test.....100
    - To Run the GPI Output Test.....100
- Error Messages.....100
- Switcher Reset.....101
  - Custom Reset Settings (RState).....101
  - Factory Default Settings.....101

## Specifications.....102

- Carbonite Black Resources.....102
- Environmental Characteristics.....102
- Video Input Specifications.....102
- Video Output Specifications.....102
- Audio Specifications.....102
- Jitter.....103
- System Timing.....103
- Network Ports.....103
- Power Consumption.....103
- Ports.....103
  - Serial Port.....103
  - GPI Port.....103
  - Tally Port.....104

---

|               |     |
|---------------|-----|
| AES Port..... | 105 |
| LTC Port..... | 105 |
| USB Port..... | 105 |

|                                   |            |
|-----------------------------------|------------|
| <b>Custom Control Events.....</b> | <b>106</b> |
|-----------------------------------|------------|

|                      |            |
|----------------------|------------|
| <b>Glossary.....</b> | <b>142</b> |
|----------------------|------------|

|                   |            |
|-------------------|------------|
| <b>Index.....</b> | <b>145</b> |
|-------------------|------------|

## Features

Thank you for buying a Ross Video Carbonite Black Series Multi-Definition Live Production Switcher. The Carbonite Black series builds on the Ross Video reputation for designing switchers that fit the needs of any production environment.

### Clean Feed Output

Clean feed is typically used for bilingual and live-to-tape productions. It provides a second Program output that is derived from a different location than the standard program output. A frequent application is the recording of shows for later airing without call-in phone numbers inserted.

The clean feed output can come from before or between the keys.

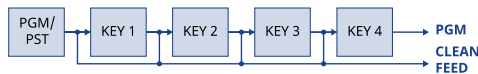

### Custom Controls

This feature brings the power of macros to the switcher operator. Button presses, menu selections, event commands, or even the switcher state can be recorded to a custom control with pauses or holds between the events. A simple button press can play these events back again. Step through complex show openings as easily as pressing Custom Control buttons 1, 2, then 3.

### Device Control

The switcher can control a number of external devices, such as video servers and robotic cameras. For a complete list of supported devices, and information on how to set up and control these devices, visit the Ross Video website

([rossvideo.com/production-switchers/carbonite/interface-list](http://rossvideo.com/production-switchers/carbonite/interface-list)).

### DVE (Fly Key)

The advanced 2D DVE comes standard with each switcher, and can be used for performing over the shoulder, or picture in picture shots. This allows all key types to be zoomed, cropped, and repositioned horizontally and vertically to create the look you want, or you can use one of

the useful pre-built 2D effects to perform 2D background transitions.

### Effects Dissolve

The Effects Dissolve feature allows you to interpolate from one memory to another using a memory recall. The switcher will interpolate from the starting memory to the destination memory, creating a smooth, two key frame effect.

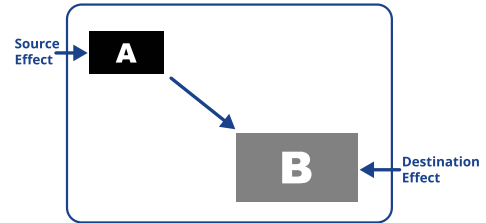

Only elements such as clip level and pattern position can be interpolated in the effects dissolve. Other elements, such as crosspoint selection, pattern, and next transition data are recalled first, and then the switcher will slew to the recalled memory.

An effects dissolve can be performed on as many elements and MEs as required, based on the memory that is being recalled.

### General Purpose Interface (GPI)

The switcher is equipped with 34 GPI I/Os that can be assigned as either an input or output independently.

The GPI inputs allow the switcher to interface with peripheral equipment such as editors. Each GPI input can be used to perform simple editing and switcher functions such as fade to black or an auto transition.

### LiveEDL

Edit Decision Lists (EDL) are files used by non-linear editing (NLE) suites to aid in post-production. Your switcher can capture EDL data in a file that you load into your NLE suite.

For information on using the LiveEDL feature, visit the Ross Video Website ([rossvideo.com](http://rossvideo.com)).

### Matte/Wash Generator

A matte generator and complex wash generator per ME, capable of multi-color washes comes standard. Any one of the color generators can be assigned to MATTE, or wipe pattern edges.

An additional simple color generator is available for an Aux Bus.

## ME Effect System

The ME (Multi-level Effect) systems are standard. The number of MEs depends on the chosen switcher model.

Each ME provides 4 keyers supporting pattern mask, box mask, self-key, linear key, and an UltraChrome advanced chroma key for each ME and is available to each keyer.

## Media-Store

Up to 4 independent channels of still/animations are available switcher-wide, allowing for thousands of full screen stills and logos that can be cached and used on the switcher.

Media-Store provides 8 GB of cache. The number of images cached increases considerably when smaller, non-full screen images like logos are loaded from USB.

## MediaManager

The MediaManager allows you to easily manage stills and animations on the switcher in a graphics interface.

## MediaWipe

A MediaWipe allows you to use an animation from the Media-Store to play over a background or key transition. When the transition starts, the switcher plays the selected animation over top of the background and keys that are being transitioned. A cut, dissolve, wipe, or DVE wipe is then performed layered under the animation to bring up the next shot when the animation ends.

## MemoryAI Recall Mode

We take the guessing out of memory recalls by ensuring that a memory recall will not affect what is currently on-air. MemoryAI uses the content of the memory to configure the Next Transition area and Preview bus for the background and keyers so that the next transition takes the same sources on-air that were on-air in the memory.

For example, store a memory that has a key on-air with CAM1 and CAM2 selected on the background. When this memory is recalled

normally, it pops the same key on-air with CAM1 and CAM2 on the background. When the memory is recalled with MemoryAI turned on, CAM1 is selected on the preset bus, and CAM2 is selected on a key that is not on-air. The transition area is then set up for a background transition to bring CAM2 onto the background, take any on-air keys off, and take a key on-air with CAM1.

## Memory System

Storage for 100 complete switcher snapshots per ME, MiniME™, and MultiScreen comes standard with all switchers. All of these memories can be stored to a USB media drive, providing custom tailored memories for every operator and every show.

## MiniME™

The MiniME™ is an additional ME that is provided with the switcher to perform basic dissolves and cuts. Each MiniME™ has 2 keyers, background, and preset buses. Unlike a full ME, the MiniME™ only supports dissolves and cuts, restricts key 1 to DVE keys only, and has no preview output. Key 2 on a MiniME™ is the same as an ME keyer. The MiniME™ shares all the same sources as the ME.

## MultiScreen

The MultiScreen is made up of a number of MultiScreen generators. Each MultiScreen breaks the scene up into separate outputs (MiniME™ outputs) that can be sent to independent projectors or displays to make a unified picture.

Each screen in the MultiScreen output uses a MiniME™ to create the background and keys of the output.

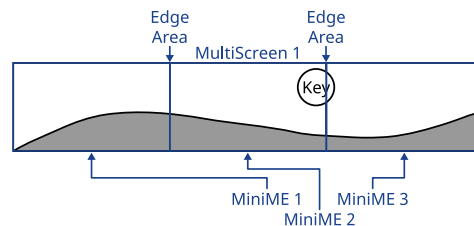

## MultiViewer

Each MultiViewer allows you to view up to 16 video sources, in 45 different layouts, from a single output BNC. Any video source on the

switcher, including ME Program, Preview, and Media-Store channels, can be routed to any box on the MultiViewer. All boxes on the MultiViewer output include mnemonic source names and red and green tallies.

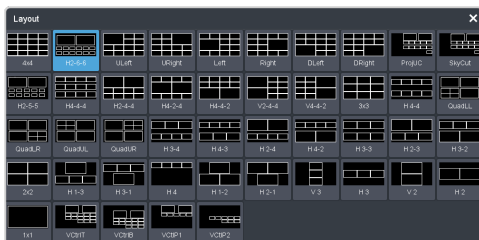

Figure 1: HD Layouts

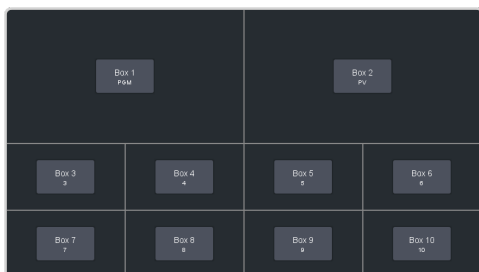

Figure 2: MultiViewer Grid

The Carbonite Black comes standard with 2 broadcast-quality integrated MultiViewer generators and the Carbonite Black+ comes standard with 5. The MultiViewer outputs on the Carbonite Black+ are only available on dedicated output BNCs. Each of these MultiViewer outputs has a specific range of input and output BNCs that can be assigned to boxes on the MultiViewer.

**Note:** If the switcher is operating in a standard-definition or 3G video format, the MultiViewer automatically outputs high-definition, but each MultiViewer is only available on specific output BNCs.

## OverDrive® Caprica Support

Carbonite can be controlled from OverDrive® using the Caprica interface. This interface allows OverDrive® to perform memory recalls, transitions, and run custom controls on the switcher. For information on setting up Caprica to interface with the switcher, refer to the documentation that came with your Caprica server.

The switcher must be in a 2.5 ME mode or have 3 MEs installed to be controlled by Caprica.

## Pattern and Matte/Wash Generators

A single pattern generator dedicated to wipes comes standard, and is equipped with 10 classic wipes. Most wipes can be rotated, bordered, multiplied, aspectized, and repositioned.

## Tally Outputs

The switcher has 34 assignable tally relays located in the rack frame. Each tally can be assigned to any number of combinations of input and output or bus.

## UltraChrome

The UltraChrome chroma keyers uses advanced video processing technology to provide exceptional blue spill reduction and clean edges, even with difficult source material. Glass, smoke, translucent materials, and natural shadows are handled superbly.

There are 2 floating Chroma Keys that are available across all MEs.

## XPression Live CG

Seamlessly combine the creative power of the Ross® XPression Designer software with the ease of use of your Ross® switcher. Create stunning still graphics using XPression Designer, and transfer them directly to an media-store channel on the switcher using the RossLinq interface. Up to two (2) channels with dedicated alpha can be controlled from the XPression Software Client. This feature supports still images only.

Each switcher comes with a single license of XPression. Additional licenses can be ordered.



# Dashboard

The Dashboard control system allows remote access to multiple pieces of Ross Video equipment, including openGear® cards, Carbonite production switchers, BlackStorm video servers, and ACID® UltraChromeHR cameras.

Download and install the latest version of Dashboard from <http://www.opengear.tv/>. Review the documentation that comes with Dashboard for information on installing and launching Dashboard.

**Note:** Carbonite Black requires Dashboard v9.1, or higher.

## Switcher Status in Dashboard

The Dashboard control system allows you to connect to the switcher and view status information for various components of the frame.

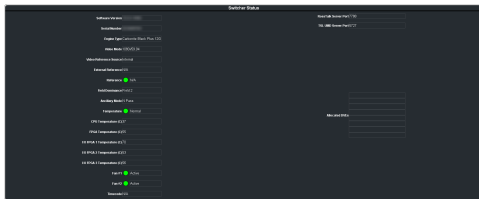

**Tip:** If the TouchDrive control panel is connected to the switcher, an additional tab for **Panel** is available that shows internal temperatures for that panel.

## Configuration

The Configuration node provides access to switcher settings such as Reference, Inputs, Outputs, and MultiViewer. You can switch between the different configurations by selecting the pages at the bottom of the Dashboard window.

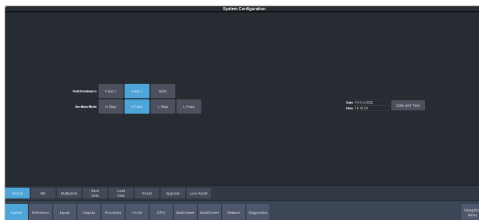

## Live Assist

The Live Assist node provides access to operational functions such as keying, transition, and memory settings of the switcher. You can switch between the different settings by

selecting the tabs at the bottom of the Dashboard window.

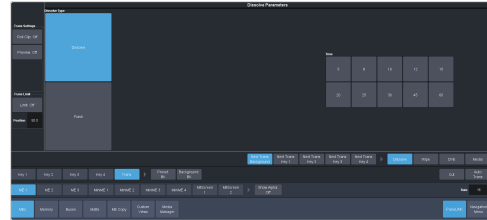

**Tip:** The **Custom View** button on the **Live Assist** page opens a separate page where you can set up custom Dashboard pages. These custom pages can also be set to auto follow specific video sources. This allows you to have Live Assist show a specific custom page when a video source is selected.

## PanelINK

PanelLink allows Live Assist to follow the button presses on the control panel and display the relevant tabs. For example, with **PanelINK** turned on, press **SEL** for any keyer and Live Assist shows the settings for that keyer. Press the **WIPE** buttons and Live Assist shows the transitions settings for a wipe. With **PanelINK** turned off, Live Assist does not switch between tabs.



**Note:** PanelLink only works on the Live Assist page.

## Custom Controls

The Custom Control provides access to recording, editing, and running custom controls, as well as setting up the mnemonics for custom control on the TouchDrive control panel.

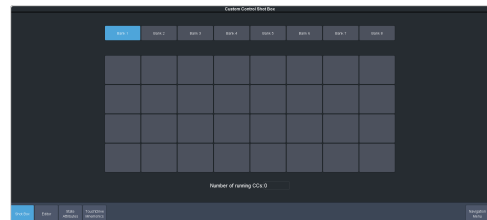

## ViewControl

The ViewControl interface through Dashboard allows you to coordinate the control over the switcher through a touchscreen interface. Through ViewControl you can select sources, perform transitions, and run custom controls.



## MediaManager

The MediaManager node allows you to control the Media-Store of the switcher. Upload media items, load media to channels, and set database elements..

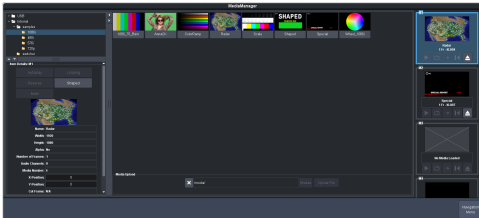

## Personality

The Personality node provides the switcher personality settings.

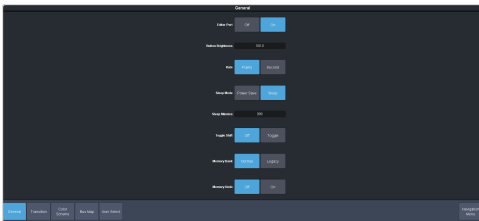

## Help

The help node in DashBoard launches the integrated help system with full search capability.

# SoftPanel

SoftPanel provides you with a graphical interface to the menu system and control surfaces of the switcher. This allows you to setup and control the switcher without a control panel.



**Important:** *SoftPanel is a separate panel connection to the frame. Refer to [MultiPanel](#) on page 98 for information on setting up SoftPanel.*

The screen can be broken up into several different functional areas. Each of these areas allows you to interact with different aspects of the switcher interface.

## Menu Area

The menu area provides a graphic representation of the menu system on a Carbonite Black control panel. The **Select**, **Up**, and **Down** buttons represent the actions of turning and pressing the knobs on the panel. The buttons in the top right corner allow you to navigate around in the menu tree, and the stylized mnemonic buttons at the bottom allow you to access different menus.



## User Area

The user area allows you to select what the bus area is assigned to, or interact with a virtual positioner. Press the **ME/Key**, **Aux Bus**, or **Positioner** button to select how the user area appears.

The **ME/Key** button allows you to select what the bus area is assigned to. Click **ME X**, **MiniME X**, or **MultSc X** to assign the bus area to that output. Click one of the **Key X Sel** buttons to assign the key bus in the bus area to that key.



The **Aux Bus** button allows you to select one of the aux buses that the key bus row in the bus area is assigned to.

**Note:** *The selection of one of the aux bus or key select buttons indicated what the key bus in the bus area is assigned to. You may have to switch between the **ME/Key** and **Aux Bus** buttons to see where the bus is assigned.*

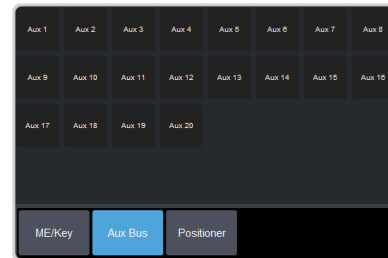

The **Positioner** button provides a virtual interface to the positioner. The positioner is used in device bus, or to move keys or masks around. Click and hold the positioner and move it around to emulate moving the positioner around. The slider to the right of the positioner emulated twisting the positioner knob on the panel. The button to the left of the positioner emulates the button on the top of the positioner knob on the panel.



## Control Area

The control area (the upper right of the screen) contains the main Dashboard interface to the switcher. Click **Navigation Menu** and select the menu you want to navigate to. When the **Live Assist** menu is selected, the sub-menus will follow actions in the bus area when **PanelINK** is on.

---

## Bus Area

The bus area provides a graphic representation of the panel row on the switcher. Use the user area buttons to assign the bus area to an ME, key, and aux bus. Sources are then selected on the key, program, and preset buses, and transitions are set up and performed with the transition buttons to the right of the source selection buttons.

*Tip: Use the **Hold On** or **2Press** buttons to emulate a press and hold of a button. This allows you to press and hold one button and then press another.*



---

## Audio and Video Processing

Video and audio signals are processed and passed through the switcher in different ways, depending on how the switcher is being used or is set up. A better understanding of how the switcher is processing these signals help you to achieve the production you want.

### Video Processing and Flow

Video is processed in a number of blocks in the switcher. After video comes into the switcher, the frame synchronizers / format converters are applied (depending on the frame you have). At this point any required color correction is also applied. After input the video signal is routed through the crosspoint. The crosspoint can route any input to any output for straight switching, or to the video processor and DVE and back for video manipulation. Just before the video signal is sent to the output, the processing of the ancillary data is performed.

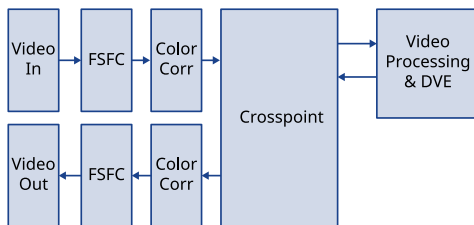

**Figure 3: Video Flow Through the Switcher**

# Video Sources

The switcher has access to three basic types of video sources, external, internal, and follows.

All video sources can be assigned to video source buttons. By pressing a video source button on a bus, the video source assigned to that button is selected on that bus.

- **External** — External video sources come from cameras, video servers, character generators, or other external devices into the switcher.
- **Internal** — Internal video sources come from internally generated video, such as Media-Store channels, matte color, and black.
- **Follows** — Follow video sources allow you to have one bus follow what is selected on another bus. For example, you can assign an Aux Bus to follow ME 1 Background so that a source selected on the background bus of ME 1 is also selected on the Aux Bus.

## To Select a Source on a Bus from Dashboard

To select a video source on a bus, you must identify the ME, MiniME™, Aux, MultiScreen, or chroma key and bus you want to assign a video source to, and then press the source button you want to select on that bus.

1. Click **Navigation Menu > Live Assist > Buses**.

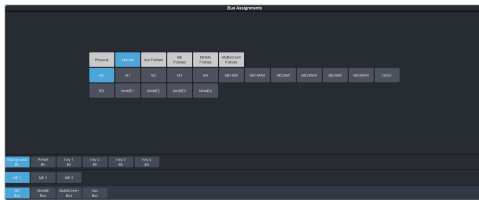

2. Click **ME Bus, MiniME Bus, MultiScreen Bus, or Aux Bus** to select the area that you want to select a source on. As you select different areas, the buses for that area are listed on the row above.
3. Click **MEX, MiniMEX, MultiScreenX, or AuxX** to select the specific bus or area you want to select a source on. With an ME, MiniME™, or MultiScreen there is an additional selection of the keyer, background, or preset bus that you want to select a source on. The aux buses do not have these selections.

4. Select the background, preset, or keyer bus that you want to select a source on. (ME, MiniME™, and MultiScreen only)

**Note:** Ensure that the source selected on the bus you want to enter onto the ME, MiniME™, MultiScreen, aux, or keyer is valid for that destination. If the source is not valid, you will not be able to select the bus on the ME, MiniME™, Aux, or keyer.

5. Select the type of source you want to assign to the bus and then select the source.
  - **Physical** — the sources on the physical input BNCs.
  - **Internal** — internally generated sources, including re-entries.
  - **Aux Follows** — use the source that is active on selected aux bus.
  - **ME Follows** — use the source that is active on selected ME bus.
  - **MiniME Follows** — use the source that is active on selected MiniME™ bus.
  - **MultiScreen Follows** — use the source that is active on selected MultiScreen bus.



# Video Layering

How video is layered in the output of the switcher depends on how an ME is re-entered onto the other, and what keyers are on-air for the ME.

If we assume that each ME has all keyers on-air and that ME 1 is re-entered into ME 2, the layering will start with ME 1 Background and progress to the highest ME and keyer.

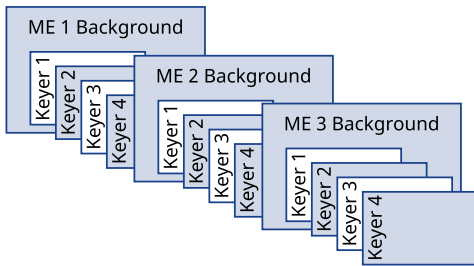

Figure 4: Video Layering

**Tip:** You can select a MiniME™ on an ME or different MiniME™ to re-enter it. Up to two MiniME™ re-entries, including an ME is allowed.

## Re-Entry

Re-entry is the term used to describe the process of selecting another ME on an ME. For example, if you select ME 1 on ME 2, ME 1 is said to be re-entered onto ME 2. Re-entry takes the output of an ME and uses it as the background or key on the other ME. If you select an ME on the background bus, the ME becomes background video source of the other ME. If you select an ME on a Key Bus, the ME becomes the key source of the other ME.

### Keep the following in mind:

Keep the following in mind when working with re-entries:

- You cannot re-enter ME 2 into ME 1, or ME 3 into ME 2.
- You cannot re-enter an ME, or the Clean Feed of an ME, into itself.

## Re-Entry Timing

To maintain proper video timing through the switcher, each MiniME™ exists in a specific timing window relative to the MiniME™. These windows restrict what can be re-entered into what.

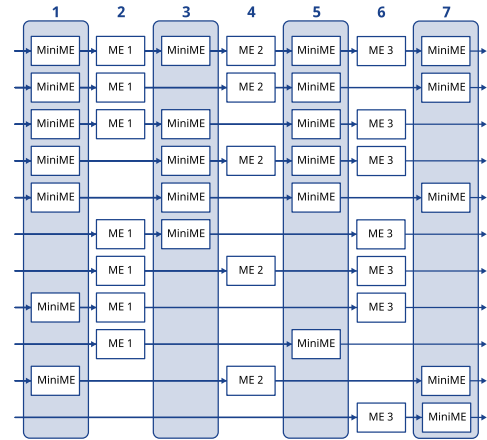

Figure 5: MiniME™ Timing Windows

## To Re-Enter an ME

The process to re-enter any bus onto another is the same as re-entering an ME onto another ME.

- Set up ME 1 with a background and a key.



- Set up ME 2 with a key.



- Select ME 1 as a source on the Background Bus of ME 2. Notice that the output of ME 1 is now being used as the background of ME 2.

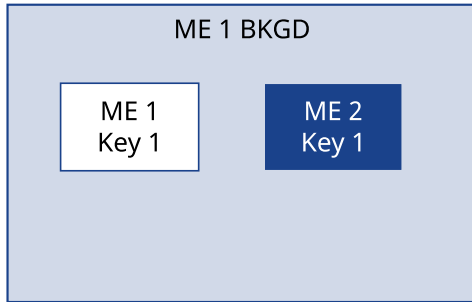

## FlexiClean Clean Feed

FlexiClean provides a second program output that is derived from a different location than the standard program output. A frequent application is the recording of shows for later airing without call-in phone numbers inserted.

The clean feed output can come from before or between the keyers.

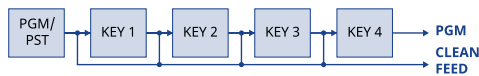

---

## Video Preview

Video preview allows you to use an additional monitor to preview what the next shot is going to be.

The preview for an ME shows what is selected for the next transition on that ME. This includes the keys and background video sources that will be on-air after the next transition.

## MultiViewer

Each MultiViewer allows you to view up to 16 video sources, in 45 different layouts, from a single output BNC. Any video source on the switcher, including ME Program, Preview, and Media-Store channels, can be routed to any box on the MultiViewer. All boxes on the MultiViewer output include mnemonic source names and red and green tallies.

---

## Matte Source

Matte color backgrounds (**BG**) are color signals that can be applied to backgrounds and keys. Color selection is done either by picking a preset color, or by adjusted hue, saturation, and luminance to create a custom color.

Select the matte generator (**BG**) on a background or key bus. The full region of the background or key is filled with the selected color.

*Note: A color background can be a solid color, or a wash of two colors.*

### To Set Up a Matte Color

1. Click **Navigation Menu > Live Assist > Matte**.

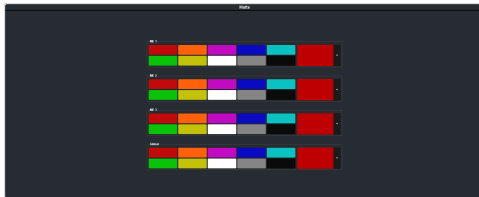

2. Select the matte generator that you want to set the color for.
  - **ME X** — set the color for the color background source on the selected ME.
  - **Global** — set the color for the global matte generator.
3. Click one of the preset colors to assign that color to the selected matte generator.

*Tip: You can select a custom color by clicking the color box to the right of the preset colors and selecting a new custom color. Toggle **Live** on to show the color changes live on the matte generator source.*

### To Set Up a Wash

A wash applies colors to a pattern selected for a matte. The first color is preset to the matte color, but both are selectable. Selecting the source button again, or **KEY SEL** button returns to this menu. Refer to the sections on mattes and patterns for information on setting them up. You can load a preset color instead of creating the first custom color.



*Important: A control panel is required to perform this procedure. If you do not have access to a physical control panel, the SoftPanel can be used. The position of items on the menus on the SoftPanel may not match those of a physical panel.*

1. Use the **Hue 1** knob to adjust the hue of the first custom color.
2. Use the **Sat 1** knob to adjust the saturation of the first custom color.
3. Use the **Lum 1** knob to adjust the luminance of the first custom color.
4. Press **NEXT**.
5. Use the **Wash** knob to select **On**.
6. Press **NEXT**.
7. Use the **Size** knob to select the size of the wash pattern.
8. Press **NEXT > NEXT > NEXT > NEXT**.
9. Use the **Hue 2** knob to adjust the hue of the second custom color.
10. Use the **Sat 2** knob to adjust the saturation of the second custom color.
11. Use the **Lum 2** knob to adjust the luminance of the second custom color.

## Copying

You can copy the content of an ME or keyer to another ME or keyer.

### ME Copy

You can copy the entire contents of an ME, MiniME™, or MultiScreen to another ME, MiniME™, or MultiScreen. The entire contents of the destination is replaced with the contents of the source.

When you copy an ME, the switcher tries to assign resources to the destination ME to match the source ME. If these resources are not available, the switcher may need to steal resources.

### To Copy an ME

Copy the contents of an ME to another.

1. Click **Navigation Menu > Live Assist > ME Copy**.



2. Click a **Destination** button to select the destination that you want to copy to.
3. Click a **Source** button to select the source you want to copy.
4. Click **Copy**.

### Key Copy

You can copy the entire contents of a keyer to another keyer in the same, or a different ME. The entire contents of the destination keyer are replaced with the contents of the source keyer.

When you copy a key, the switcher tries to assign resources to the destination key to match the source key. If these resources are not available, the switcher steals resources in the following order:

1. From off-air keys that are not the source key.
2. From the source key, if it is not on-air.
3. From on-air keys that are not the source key.
4. From the source key, even if it is on-air.

### To Copy a Key

This procedure copies the contents of Key 1 to Key 3 as an example. Use the same procedure for any key combination.



**Important:** A control panel is required to perform this procedure. If you do not have access to a physical control panel, the SoftPanel can be used. The position of items on the menus on the SoftPanel may not match those of a physical panel.

1. Press and hold the **KEY 3 SEL** button.  
This is the destination keyer that you want to copy to.
2. Press the **KEY 1 SEL** button.  
This is the source keyer that you want to copy from.

### Key Swap

You can swap the entire contents of any two keyers in the same, or different MEs. The video source, position, and key type are all swapped between keyers. This allows you to change the apparent key priority, or layering, of the keys in the video output. For example, key 3 appears over key 2. If you perform a swap between key 3 and key 2, it appears as if key 2 is now over key 3.

#### Keep the following in mind:

Keep the following in mind when performing a key swap:

- Key swap does not change the on-air status of a keyer.
- If a DVE key is set to freeze, it will be unfrozen by the swap.
- A key swap can be recorded as part of a custom control.

### To Perform a Key Swap

This procedure swaps the contents of Key 2 and Key 3 as an example. Use the same procedure for any key combination.



**Important:** A control panel is required to perform this procedure. If you do not have access to a physical control panel, the SoftPanel can be used. The position of items on the menus on the SoftPanel may not match those of a physical panel.

1. Press and hold the **KEY 2 SEL** button.
2. Press the **KEY 3** button in the transition area.

# Transitions

Transitions are used to change the background video and take keys on and off-air. A transition can include any combinations of background and keyers for an ME, MiniME™, or MultiScreen. The background and each keyer can be transitioned independently.

## Performing Transitions

What you can include in the transition, and the type of transition you can perform, depend on the number of resources you have, and if you are performing a background and keyer transition at the same time.

### Keep the following in mind:

Keep the following in mind when performing transitions:

- If any of the sources going on-air have an assigned GPI output, the GPI output is triggered and the switcher then waits the configured pre-delay interval before performing the transition. If you perform a transition with the fader handle, the GPI output is triggered but the pre-delay interval is ignored.
- If any of the sources going on-air are assigned to a video server, you can have the video server play when the source is taken on-air by toggling **Roll Clip** on.
- If any of the sources going on-air are assigned to a video server, the switcher waits for the configured pre-delay interval before performing the transition. If you perform a transition with the fader handle, the pre-delay interval is ignored.
- If the fader is moved during an auto transition, control of the transition is passed to the fader. You must complete the transition with the fader. This allows you to override any auto transition in progress with the fader.
- The **Cut** and **Auto** buttons can be used to transition keys independently.
- You can pause an auto transition by pressing the **Auto Trans** button during the transition. Press the button again to continue the transition.
- If you turn the Transition Limit off when the transition has stopped at the transition limit point, the next transition starts from the

transition limit point and goes forward to complete the transition, instead of going back to the start.

- On a MiniME™, Background and key 2 only support Dissolve and Cut transitions.

## To Perform a Transition

All transitions, with the exception of cuts on the background or key bus, have the same basic setup. The touchscreen menu system offers the touchscreen interface to setup and perform the transition.

1. Click **Navigation Menu > Live Assist > MEs.**

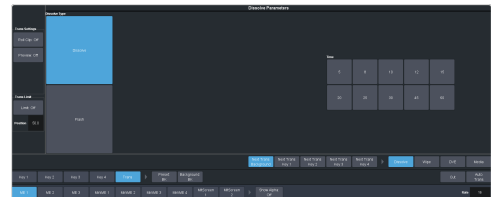

2. Click the **ME X, MiniME X, or MultiScreen X** for the area you want to perform the transition on.
3. Select the video sources you want to take on-air on each bus. Background and keys are set up slightly differently but can be performed with the same transition.
  - **Background** — click **Trans > Preset** and select the new background source.
  - **Key On-Air** — click the **Key X > Key Fill** button for the key you want to take on-air and select the new source. Repeat this for each key you want to take on-air.
  - **Key Off-Air** — you don't need to select the keys at this point.

*Tip: Refer to [To Select a Source on a Bus from Dashboard](#) on page 20 for information on selecting sources.*

4. Click **Trans.**
5. In the Next Transition area, select the elements (Background and Keys) you want to include in the next transition. You can include any combination of background and keys, but at least one element must be selected.

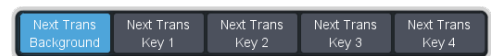

6. In the **Rate** field, enter the rate that you want the transition performed at. This is the speed, in frames, that it takes for the transition to complete. A Cut or manual



fader transitions do not use the transition rate.

- **Background** — enter a new ME transition rate, in frames, in the **Trans Rate** field.
- **Key Only** — enter a new key transition rate, in frames, in the **Key X Rate** for the key you want to transition.

*Note: The key rate is only used for key only transitions. Keys included in with the background are transitioned a the ME Rate.*

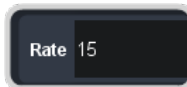

7. In the Transition area, select the type of auto transition you want to perform. If you want to perform a cut you do not need to select a transition type and can move to the next step.



- **DISS** — perform a dissolve or WhiteFlash auto transition. Refer to [To Set Up a Dissolve](#) on page 31 or [To Set Up a WhiteFlash](#) on page 31 for more information.
- **WIPE** — perform a wipe auto transition. Refer to [To Set Up a Wipe](#) on page 32 for more information.
- **DVE** — perform a DVE auto transition. Refer to [To Set Up a DVE Transition](#) on page 32 for more information.
- **MEDIA WIPE** — perform a MediaWipe auto transition. Refer to [To Set Up a MediaWipe](#) on page 33 for more information.

8. Click a **Trans Settings** button to turn the setting on or off. The options available depend on the type of transition selected.



- **Roll Clip** — select whether you want any video server clips assigned to a source being taken on-air to play with the transition (**On**), or not (**Off**).
- **Preview** — preview the transition on the preview output **On**. You cannot preview the independent key-only transitions or a MiniME™ transition.
- **Flip Flop** — select whether the wipe runs forward during the first transition and then reverse during the second (**On**), or if it always runs in the same direction (**Off**).
- **Direction** — select the direction that the wipe travels.

9. Click **Limit** to turn trans limit **On** or **Off**. Enter a value for the trans limit in the **Position** field to set the point in a transition where an auto transition stops. When active, the point in the transition where the auto transition will stop is indicated by a flashing segment on the transition progress bar next to the fader handle on the control panel. The auto transition proceeds to this point and stops. The second auto transition starts from the transition limit point and goes back to where the first transition started.

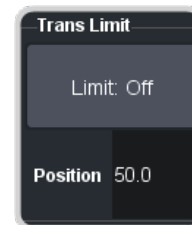

*Tip: The Limit Position is a percentage with 0 being the starting point of the transition and 100 being the ending point of the transition.*

10. Perform the transition.



**Important:** The **Cut** and **Auto** buttons trigger a transition on what has been selected. If **Trans** is selected a normal background transition is performed. If one of the keys is selected (**Key X**) a key-only transition is performed on the selected key.

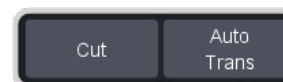

- **Auto Trans** — click **Auto Trans**
- **Cut** — click **Cut**

*Tip: During an auto trans, press **Auto Trans** again to hold the transition at the current position or press **Cut** to abort the transition and return to the original source.*

- If a pre-delay has been set, and **Roll Clip** is active, the switcher will apply the pre-delay interval before performing the transition.

## To Perform a Transition on TouchDrive (Memory Area)

All transitions, with the exception of cuts on the background or key bus, have the same basic setup. The control panel offers physical buttons and mnemonics to setup and perform the transition. Some panels have a memory area that can be used to set the transition rates.

- Select the preset or key sources that you want to transition to on the buses.

**Tip:** You can perform a quick, or hot, cut on the background bus by simply selecting a different source.

- In the **Transition** area, select the elements you want to include with the transition. If you are including multiple elements, press and hold the first button and press the other buttons to include them in the same transition.

**Note:** A key should be included in the transition if it is going on-air or off-air. The transition changes the on-air state of the keyer. If a key is on-air, a red indicator is visible on the display just above the key and the **CUT** button for that key is red in the **Keyer** area.

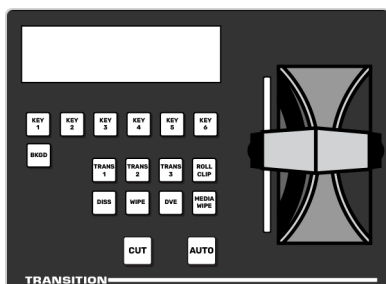

- In the **Transition** area, select the type of auto transition you want to perform. Refer to the manual that came with your switcher for information on setting up these transitions.

- DISS** — perform a dissolve or WhiteFlash transition
- WIPE** — perform a wipe transition
- DVE** — perform a DVE transition
- MEDIA WIPE** — perform a MediaWipe transition

**Note:** The **TRANS X** buttons are configurable and can be assigned different functions.

**Tip:** Press and hold **DISS** and press **Flash** on the row control menu to select a WhiteFlash transition.

- The display in the **Transition** area shows the current setting for the transition type. Tap one of these settings to show additional options.

**Tip:** Live Assist follows the transition type selection and shows the settings for that transition type.

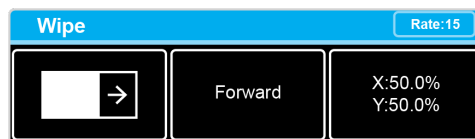

- Left** — the left button shows the current pattern for the wipe or DVE transition. Tap the button and swipe left or right on the display to select a different pattern. For a MediaWipe the button shows the name of the media item being used for the transition.
- Center** — the center button shows the current direction for the wipe, DVE, or MediaWipe transition. Tap the button and select a different direction for the transition to be performed in.
- Right** — the right button shows the current position of the pattern for the wipe transition or the settings for the MediaWipe transition. Tap the button to have the 3-knob display show the position setting of the pattern and use the positioner to move the pattern around.

- In the **Memory** area, enter the rate that you want the transition performed at. This is the speed, in frames, that it takes for the transition to complete. A Cut or manual fader transition does not use the transition rate.

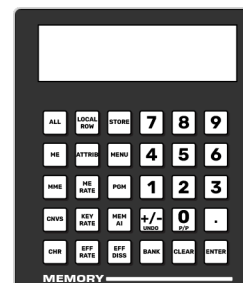

- Background** — press **ME RATE** and use the keypad to enter a new rate, in frames, and press **ENTER**. The rate is shown on the display on the **Transition** area.
- Key Only** — press **KEY RATE** and use the keypad to enter a new rate, in frames,

and press **ENTER**. The rate is shown on the **Keyer** area for each individual key.

**Note:** The **KEY RATE** is only used for key only transitions. Keys included in with the background are transitioned at the **ME Rate**.

6. Perform the transition.
  - **Auto Transition** — press **AUTO**. The transition is performed at the set transition rate.
  - **Cut** — press **CUT**.
  - **Fader** — move the fader from one limit to the other. The rate at which you push the fader determines the speed of the transition.
7. If a pre-delay has been set, and the **ROLL CLIP** button is active, the switcher will apply the pre-delay interval before performing the transition.

## To Perform a Transition on TouchDrive (No Memory Area)

All transitions, with the exception of cuts on the background or key bus, have the same basic setup. The control panel offers physical buttons and mnemonics to setup and perform the transition.

1. Select the preset or key sources that you want to transition to on the buses.

**Tip:** You can perform a quick, or hot, cut on the background bus by simply selecting a different source.

2. In the **Transition** area, select the elements you want to include with the transition. If you are including multiple elements, press and hold the first button and press the other buttons to include them in the same transition.

**Note:** A key should be included in the transition if it is going on-air or off-air. The transition changes the on-air state of the keyer. If a key is on-air, a red indicator is visible on the display just above the key and the **CUT** button for that key is red in the **Keyer** area.

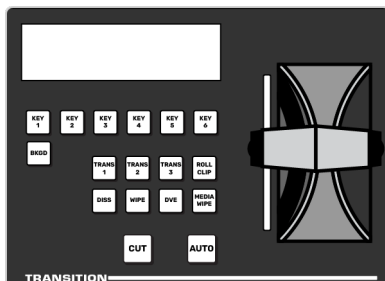

3. In the **Transition** area, select the type of auto transition you want to perform. Refer to the manual that came with your switcher for information on setting up these transitions.
  - **DISS** — perform a dissolve or WhiteFlash transition
  - **WIPE** — perform a wipe transition
  - **DVE** — perform a DVE transition
  - **MEDIA WIPE** — perform a MediaWipe transition

**Note:** The **TRANS X** buttons are configurable and can be assigned different functions.

**Tip:** Press and hold **DISS** and press **Flash** on the row control menu to select a WhiteFlash transition.

4. The display in the **Transition** area shows the current setting for the transition type. Tap one of these settings to show additional options.

**Tip:** Live Assist follows the transition type selection and shows the settings for that transition type.



- **Left** — the left button shows the current pattern for the wipe or DVE transition. Tap the button and swipe left or right on the display to select a different pattern. For a MediaWipe the button shows the name of the media item being used for the transition.
  - **Center** — the center button shows the current direction for the wipe, DVE, or MediaWipe transition. Tap the button and select a different direction for the transition to be performed in.
  - **Right** — the right button shows the current position of the pattern for the wipe transition or the settings for the MediaWipe transition. Tap the button to have the 3-knob display show the position setting of the pattern and use the positioner to move the pattern around.
5. Set the rate for the transition you want to perform.
    - **Background**

- a. On the Transition area tap **Rate** and use the 3-knob menu to enter the new rate.

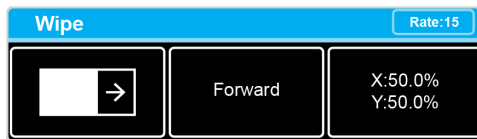

- **Key Only**

*Note: The KEY RATE is only used for key only transitions. Keys included in with the background are transitioned a the ME Rate.*

- a. On the Keyer area tap the key you want to set the rate for.

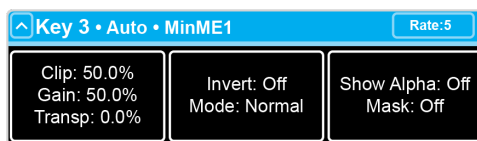

- b. Tap **Rate** and use the 3-knob menu to enter the new rate.

6. Perform the transition.
  - **Auto Transition** — press **AUTO**. The transition is performed at the set transition rate.
  - **Cut** — press **CUT**.
  - **Fader** — move the fader from one limit to the other. The rate at which you push the fader determines the speed of the transition.
7. If a pre-delay has been set, and the **ROLL CLIP** button is active, the switcher will apply the pre-delay interval before performing the transition.

## To Perform a Transition on Carbonite Black

All transitions, with the exception of cuts on the background or key bus, have the same basic setup. The control panel offers physical buttons and mnemonics to setup and perform the transition.

1. Select the preset or key sources that you want to transition to on the buses.

*Tip: You can perform a quick, or hot, cut on the background bus by simply selecting a different source.*

2. In the **Transition** area, select the elements you want to include with the transition. If you are including multiple elements, press and hold the first button and press the other

buttons to include them in the same transition.

*Note: A key should be included in the transition if it is going on-air or off-air. The transition changes the on-air state of the keyer. If a key is on-air, a red indicator is visible just above the include button for that key and the **CUT** button for that key is red in the **Keyer** area.*

3. In the **Transition** area, select the type of auto transition you want to perform. Refer to the manual that came with your switcher for information on setting up these transitions.
  - **DISS** — perform a dissolve or WhiteFlash transition
  - **WIPE** — perform a wipe transition
  - **DVE** — perform a DVE transition
  - **MEDIA WIPE** — perform a MediaWipe transition

*Note: The **USER** button is configurable and can be assigned different functions.*

4. In the **Memory** area, enter the rate that you want the transition performed at. This is the speed, in frames, that it takes for the transition to complete. A Cut or manual fader transition does not use the transition rate.

*Note: If your control panel does not have a memory area, you can use the **Time** knob on the 3-knob menu, or **DashBoard**, to set the background transition rate.*

- **Background** — press **ME RATE** and use the keypad to enter a new rate, in frames, and press **ENTER**.
- **Key Only** — press **KEY RATE** and use the keypad to enter a new rate, in frames, and press **ENTER**.

*Note: The KEY RATE is only used for key only transitions. Keys included in with the background are transitioned a the ME Rate.*

5. Perform the transition.
  - **Auto Transition** — press **AUTO**. The transition is performed at the set transition rate.
  - **Cut** — press **CUT**.
  - **Fader** — move the fader from one limit to the other. The rate at which you push the fader determines the speed of the transition.
6. If a pre-delay has been set, and the **ROLL CLIP** button is active, the switcher will apply

the pre-delay interval before performing the transition.

## Cut Transitions

A Cut is an instantaneous transition between video sources. Unlike all the other transition types, there are no intermediate steps between the video source that is on-air, and the video source you are transitioning to.



A cut is performed either by selecting different sources on a background or key bus, or by pressing a **Cut** button.

## Dissolve Transitions

A Dissolve is a gradual fade between video sources. For a Background transition, the video signal on the Background bus and the video signal on the Preset bus are mixed together until the Preset bus video signal completely replaces the Background bus video signal.



### To Set Up a Dissolve

A dissolve transition requires that you set a background and key transition rate for the auto transition. A fader transition does not use the transition rate.

1. Click **Navigation Menu > Live Assist > MEs** and select the ME that you want to perform the transition on.

*Tip: You can use the same procedure for a MiniME™ or MultiScreen.*

2. Click **Trans > Dissolve**, or press **DISS** in the **Transition** area on the control panel.



3. Click **Dissolve**.

## WhiteFlash

Perform a two-step transition where a dissolve to and from white, or other selected color, is

performed in the middle of the transition. The video signal on the Background bus is transitioned to a color background of the selected WhiteFlash color. The color background is then transitioned to the preset bus. WhiteFlash consumes a pattern generator for the transition.

Each ME has a separate WhiteFlash generator.

### To Set Up a WhiteFlash

A WhiteFlash transition is performed just like a normal dissolve except that you must set the color for the flash and the rates for the onset, hold, and fade.

1. Click **Navigation Menu > Live Assist > MEs** and select the ME that you want to perform the transition on.

*Note: A WhiteFlash can only be performed on an ME.*

2. Click **Trans > Dissolve**, or press **DISS** in the **Transition** area on the control panel.
3. Click **Flash**.

*Tip: The DISS button on the control panel flashes indicating a WhiteFlash transition has been selected.*

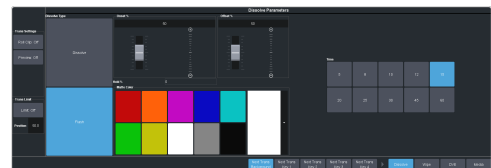

4. Use the **Onset %** and **Offset %** sliders to select the percentage of the transition that each phase of the WhiteFlash takes.
  - **Onset** — duration of the dissolve to the WhiteFlash color.
  - **Offset** — duration of the dissolve to the preset video source.
  - **Hold** — duration of the dissolve that the WhiteFlash color is held. This value is the residual of entire duration minus the onset and offset.
5. Select a default or custom color for the WhiteFlash.
  - **Default** — click one of the preset matte colors.
  - **Custom** — click the arrow to the right of the **Matte Color** area and use the **Hue**, **Saturation**, and **Lightness** sliders to select your own color. Click **OK** to apply the color or **Live** to apply it in real-time.



## Wipe Transitions

A Wipe is a gradual transition where one video signal is replaced with another according to a wipe pattern. In the example below, a line wipe is being used.



For Key transitions, the key is wiped on or off-air with the transition and the background remains untouched. The duration of a wipe transition depends on either the transition rate for the ME, or the rate at which the fader is moved.

### To Set Up a Wipe

A wipe transition requires that you select a wipe pattern, set the direction and number/size of wipe pattern, as well as set a background and key transition rate for the auto transition. A fader transition does not use the transition rate.

1. Click **Navigation Menu > Live Assist > MEs** and select the ME that you want to perform the transition on.

*Note: A wipe can only be performed on an ME.*

2. Click **Trans > Wipe**, or press **WIPE** in the **Transition** area on the control panel.



3. In the **Wipe Pattern** area, select the pattern that you want to use for the wipe.
4. Set up the wipe pattern as required.
  - **Wipe Aspect** — adjust the aspect ratio of the wipe pattern. Not all patterns can be adjusted.
  - **H-Multiply** — multiply the pattern horizontally.
  - **V-Multiply** — multiply the pattern vertically.
  - **X-Position** — position the pattern on the x-axis.
  - **Y-Position** — position the pattern on the y-axis.
  - **Rotation** — rotate the pattern. Not all pattern can be rotated.

- **Border Size** — apply a border to the pattern and adjust the size. At size 0 the border is off.
- **Border Softness** — apply softness to the border.
- **Border Color** — select a color for the border. You can choose between the predefined colors or use the color picker to select a custom color.

## DVE Transitions

A DVE transition is a gradual transition where one video signal is replaced with another according to a 2D DVE pattern.

### Keep the following in mind:

Keep the following in mind when performing DVE transitions:

- You must include the background when performing a DVE transition on a Chroma Key, Self Key, or Auto-Select Key. If you do not include the background, a dissolve transition is performed.
- Performing a DVE transition on a DVE Key without including the background scales the transition effect to the size of the DVE Key. This transition does not consume an additional DVE resource.
- Performing a DVE transition on a DVE Key with the background included does not scale the transition effect. This transition consumes the second DVE resource.
- You cannot perform a DVE transition on a MultiScreen.
- You can only perform a DVE transition on a DVE key on a MiniME™. If the transition includes the Background, or a keyer that is not set as a DVE, the transition is switched to a dissolve.

### To Set Up a DVE Transition

A DVE transition requires that you select the DVE pattern and duration for the transition.

1. Click **Navigation Menu > Live Assist > MEs** and select the ME that you want to perform the transition on.
2. Click **Trans > DVE**, or press **DVE** in the **Transition** area on the control panel.



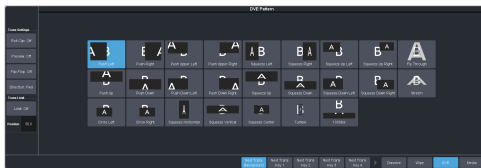

3. Click a **DVE Pattern** button to select the DVE wipe pattern you want to use.

## MediaWipe Transitions

A MediaWipe allows you to use an animation to cover a transition. When the transition starts, the switcher plays the selected animation over top of the background and keys that are being transitioned. A MediaWipe can be used to cover a cut, dissolve, wipe, or DVE transition.

For a cut MediaWipe, the transition is performed when the cut point is reached. It is important to use a full-screen image in the animation at the cut point so that the cut is not visible on-air.

### Keep the following in mind:

Keep the following in mind when performing MediaWipe:

- Although you can select a still image for a media transition, it is not recommended.
- Only Auto Transition should be used for Media transitions. Using the fader to perform the transition manually could result in jumps in the animation.
- The duration of the transition (Time) is set by the length of the animation and the play speed of the animation.
- The audio associated with a MediaWipe is only available on the AES outputs.
- You cannot perform a MediaWipe transition on a MiniME™ or MultiScreen.
- Only Media-Store channels 1 and 2 can be used for a MediaWipe.
- The MediaWipe can be set to occur between any of the keys or the background. When you set the layer to a specific key, the MediaWipe animation will cover that key, even if the key is not part of the transition. The animation plays over the key, but the key remains after the animation is finished. Any keys above the MediaWipe layer remain on top of the animation.

## To Set Up a MediaWipe

A MediaWipe requires that you select the animation you want to use and then set up how you want transition performed under the animation. This information is stored with the media item when you press save.

1. Click **Navigation Menu > Live Assist > MES** and select the ME that you want to perform the transition on.
2. Click **Trans > Media**, or press **MEDIA** in the **Transition** area on the control panel.



3. In the **Media Status** area, click a **Media X** button to select the channel you want to assign an animation to.
4. In the **Media Selection** area, click the thumbnail box for the animation you want to assign to the Media-Store channel.

*Tip:* Enter the media item number for a media item in the field below the thumbnail button assign that button to the media item.

*Tip:* Click **Page 1** or **Page 2** to move between the pages of MediaWipe animations.

5. In the **Trans Layer** area, select where the MediaWipe will occur.
  - **Auto** — MediaWipe occurs over highest number key in the transition.
  - **Bkgd** — MediaWipe occurs over the background, but under all keys.
  - **Key1** — MediaWipe occurs over the background and key 1, but under remaining keys.
  - **Key2** — MediaWipe occurs over the background and key 1 and 2, but under remaining keys.
  - **Key3** — MediaWipe occurs over the background and key 1, 2, and 3, but under key 4.
  - **Key4** — MediaWipe occurs over the background and all keys.



*Important:* If a key is above the MediaWipe layer and included in the MediaWipe transition, it will cut off-air with the transition. This is normally covered by the animation when the layer is above the key.

6. Click **Edit Media Trans.**



7. In the **Media Over** area, select the type of transition you want to use under the MediaWipe. This also allows you to set up the transition parameters for wipes and DVE transitions.
8. Click **Trans Time** and use the slider or fader in the **Transition** area on the control panel to set the start and end of the transition under the MediaWipe.
  - (Cut only) Use the **Cut Frame** slider to select the point for the cut, or move the fader to the point in the animation where you want the cut to happen and click **Cut at Fader Position**.
  - Use the **Start Trans At** slider to select the point where the transition starts, or move the fader to the point in the animation where you want the transition to start and click **Start Trans at Fader Position**.
  - Use the **Trans Rate** slider to select the duration of the dissolve, or move the fader to the point where you want the transition to end and click **End Trans at Fader Position**.

*Tip: If you select a negative start point for the transition, the transition will start first and then the animation will play after the start point duration has passed.*

9. Click **Thumbnail** and use the **Thumbnail** slider to select a point in the animation that you want to use as a thumbnail for the MediaWipe. You can also use the fader to select the position and click **Generate Thumbnail at Fader Position**.
10. Click **Save** to save the new setting to the selected media item.
11. Click **Exit Edit Media Trans**.

# Keying

Keying is the term used to describe when you insert (or electronically cut) portions of one scene into another, or place titles over background images. Keys are made up of two basic components, an alpha, that cuts the hole in the background video, and a fill, that fills the hole with different video.

Keys, like MEs, are layered onto the background video signal from the lowest numbered key to the highest on an ME.

**Note:** DashBoard Live Assist will not notify you of error messages or if a confirmation is required. For example, if there are no available resources for the DVE Key, or Chroma Key, you are trying to create, the switcher will not create the key and no notification will be shown.

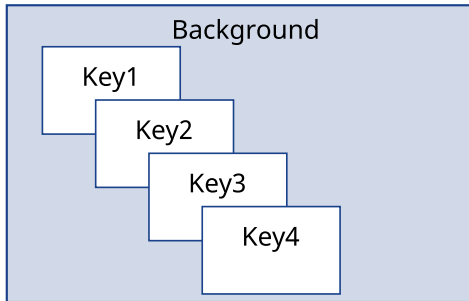

Figure 6: Key Priority

## Self Keys

A Self Key is a key in which the luminance, or brightness, values of the key source are used as the alpha for the key.

### To Set Up a Self Key

A self key is set up by selecting the keyer and video source you want to use, and adjusting the key parameters.

1. Click **Navigation Menu > Live Assist > MEs** and select the ME and key that you want to set up.

**Tip:** You can use the same procedure for a MiniME™ or MultiScreen.

2. Click **Key Fill** and select the video signal you want to use for the key.
3. Click **Self Key**.



**Tip:** Click **Show Alpha** to have the preview output of the current ME switch to the alpha signal that is being used by the selected keyer. Show alpha is not available for MiniME™ outputs.

**Tip:** Click **Make Linear** to return the clip and gain values to the default settings.

4. Use the **Clip** slider to remove lower-saturated colors from the video image.
5. Use the **Gain** slider to adjust the transition between the video image and the parts of the video image that are removed.
6. Use the **Transparency** knob to adjust the transparency of the key from opaque (**0**) to fully transparent (**100**).
7. Click **Key Invert** to reverse the polarity of the key alpha so that the holes in the background are cut by dark areas of the key alpha instead of bright areas.
8. Click a **Keyer Mode** button to override the shaped setting for the key.
  - **Normal** — set to a linear keyer for an unshaped source.
  - **Additive** — set to an additive keyer for a shaped source. The **Make Linear** function is disabled in this mode.
  - **Full** — set the alpha to fully opaque (white). The **Clip**, **Gain**, **Make Linear**, and **Key Invert** functions are disabled in this mode.
9. Click **Mask** to apply a mask to the key.

## Auto Select Keys

An Auto Select key is a key in which two video signals are required to make the key. The alpha is used to cut the hole in the video and the fill is used to fill the hole. These signals often originate from external devices such as character generators, external still stores, or other graphics systems.

### To Set Up an Auto Select Key

An auto select key is set up by selecting the keyer and video source you want to use, and adjusting the key parameters. The pairing of the video and alpha video signals is done when configuring video inputs. Refer to the Setup Manual that came with your switcher for information on setting up Auto Keys.

1. Click **Navigation Menu > Live Assist > MEs** and select the ME and key that you want to set up.

*Tip: You can use the same procedure for a MiniME™ or MultiScreen.*

2. Click **Key Fill** and select the video signal you want to use for the key.
3. Click **Auto Select**.



*Tip: Click **Show Alpha** to have the preview output of the current ME switch to the alpha signal that is being used by the selected keyer. Show alpha is not available for MiniME™ outputs.*

*Tip: Click **Make Linear** to return the clip and gain values to the default settings.*

4. Use the **Clip** slider to remove lower-saturated colors from the video image.
5. Use the **Gain** slider to adjust the transition between the video image and the parts of the video image that are removed.
6. Use the **Transparency** knob to adjust the transparency of the key from opaque (**0**) to fully transparent (**100**).
7. Click **Key Invert** to reverse the polarity of the key alpha so that the holes in the background are cut by dark areas of the key alpha instead of bright areas.
8. Click a **Keyer Mode** button to override the shaped setting for the key.
  - **Normal** — set to a linear keyer for an unshaped source.
  - **Additive** — set to an additive keyer for a shaped source. The **Make Linear** function is disabled in this mode.
  - **Full** — set the alpha to fully opaque (white). The **Clip**, **Gain**, **Make Linear**, and **Key Invert** functions are disabled in this mode.
9. Click **Mask** to apply a mask to the key.

## UltraChrome Chroma Key

An UltraChrome Chroma Key is a key in which the hole is cut based on a color value, or hue, rather than a luminance value or alpha signal.

The color is removed and replaced with background video from another source. The default color is blue.

Chroma Key adjustments are persistent and are not affected by a soft reset or switcher reboot. However, initializing the Chroma Key or performing a factory reset returns all adjustments to default values.

## Chroma Key Modes

The UltraChrome Chroma Key operates in one of two modes, Basic or Advanced, depending on the complexity of the Chroma Key you are setting up.

- **Basic Mode** — In basic mode, UltraChrome provides a simple background/foreground chroma key with adjustment for background spill and edge softness.
- **Advanced Mode** — In advanced mode, UltraChrome provides advanced background shadow and translucency control, as well as control over background/foreground transition areas.

Although it is possible to switch back and forth between advanced and basic mode, the additional image correction of the advanced mode is only applied in the advanced mode. For example, if you use the basic mode to set up the Chroma Key and then switch to the advanced mode, the entire image may change as the image correctors provided by the advanced mode are applied at their default settings.

## Chroma Key Basic Mode

The following chroma key parameters can be adjusted in Basic Mode:

- **Background Gain** — Allows you to modify the range of colors that are considered background and are masked out of the Chroma Key.
- **Edge Softness** — Allows you to adjust the amount of edge softening applied to the foreground. This helps blend the foreground into the new background.
- **Foreground Clip/Hue/Reject** — Allows you to modify the range of colors that are considered foreground and are not masked.
- **Spill Range** — Allows you to remove background color casts that may spill into the foreground image (green color cast on the foreground from a green-screen for example).

## To Set Up a Chroma Key in Basic Mode

The UltraChrome chroma key tries to automatically adjust for the scene you are trying to chroma key. For the best results, initialize the key first, and then identify the areas where you need to adjust the key.

1. Click **Navigation Menu > Live Assist > MEs** and select the ME and key that you want to set up.

*Tip: You can use the same procedure for a MiniME™ or MultiScreen.*

2. Click **Key Fill** and select the video signal you want to use for the key.
3. Click **Chroma Key**.

*Tip: Click **Show Alpha** to have the preview output of the current ME switch to the alpha signal that is being used by the selected keyer. Show alpha is not available for MiniME™ outputs.*

4. Click **Basic**.



5. Click the **Color** button for the color you want to key out.
6. Click **Init** to initialize the chroma key.  
Every time the key is initialized, the switcher resets all the Chroma Key parameters to their default settings.
7. Click an **Additive Keying** button to turn it on or off.
  - **Off** — Reduces the level of detail in the edges of the chroma key as well as the overall noise in the key image that can be the result of certain lighting conditions or high detail camera settings. This is the default setting.
  - **On** — Include the maximum detail in the edges of the chroma key.
8. Use the **Background Gain** slider to adjust the background gain.
  - Increasing the gain value causes the background to appear more opaque. This results in less of the background color being removed.
  - Decreasing the gain value causes the background to appear more transparent.

This results in more of the background color being removed.

9. Use the **Edge Softness** slider to add or remove edge softening of the foreground image and alpha channel.
  - Increasing the softness value increases the amount of softness applied to the foreground edges and alpha channel.
  - Decreasing the softness value decreases the amount of softness applied to the foreground edges and alpha channel.
10. Use the **Foreground Clip** slider to adjust the foreground clipping.
  - Increasing the clip value removes lower-saturated colors from the foreground image.
  - Decreasing the clip value includes lower-saturated colors in the foreground image.
11. Use the **Foreground Hue** slider to select the central (base) color for the foreground.
  - Increasing the hue value moves counter-clockwise around the color wheel to select a base color.
  - Decreasing the hue value moves clockwise around the color wheel to select a base color.
12. Use the **Foreground Reject** slider to include or reject hues adjacent to the base color.
  - Increasing the Reject value decreases the amount of adjacent hues that are included in the foreground.
  - Decreasing the Reject value increases the amount of adjacent hues that are included in the foreground.
13. Use the **Spill Range** slider to remove any color cast onto the foreground.
  - Increasing the range value causes more of the foreground colors to be corrected for background color spill.
  - Decreasing the range value causes fewer of the foreground colors to be corrected for background color spill.
14. Click **Mask** to apply a mask to the key.

## Chroma Key Advanced Mode

An UltraChrome chroma key, in advanced mode, breaks the image into five elements which



determine, or partially determine, which part of the image is keyed out, or removed.

- **Background** — Background elements are those pixels in the source video that are the same color as the one you chose to key out. Note that the Shadow and translucent areas (see below) are completely contained within the Background area.
- **Shadow** — Shadow elements are those pixels in the source video with colors that are within the Background range, but with lower luminance values, depending on the shadow range. You modify the Shadow range to cover darker areas of the background (e.g. where the foreground is casting a shadow on the background screen).
- **Translucency** — Translucent elements are those pixels in the source video that are in the Background range, but with higher luminance values than the Shadow range. You can control the upper-end of the Translucency range by setting a wider hue-range to constrain the area. You can also control the transparency of the Translucent area.
- **Transition** — Transition elements are those pixels in the source video with colors that are not within any of the previous three ranges and are also not considered part of the Foreground area. These are typically the pixels near the edge of the foreground, where it blends into the background.
- **Foreground** — Foreground elements are those pixels that are not within the Background, Shadow, Translucency, or Transition ranges. This is the area with colors that will not be keyed out and will remain solid.
- **Spill Suppress** — Spill Suppression elements are those pixels in the Foreground that have a noticeable tint of the Background color. This typically occurs around the edge of the foreground subject as glow from the background blue-screen or green-screen “spills” onto them.
- **Edge Softness** — Edge Softness lets you apply varying degrees of softening to the Foreground edges to help it blend in with the underlying background image that it is being keyed over.
- **Luminance** — Luminance allows you to control the overall brightness of Shadow, Translucency, and Transition areas as well

as partial reflections to more closely match the Foreground brightness.

## To Set Up a Chroma Key in Advanced Mode

The UltraChrome chroma key tries to automatically adjust for the scene you are trying to chroma key. For the best results, initialize the key first, and then identify the areas where you need to adjust the key.

1. Click **Navigation Menu > Live Assist > MEs** and select the ME and key that you want to set up.

*Tip: You can use the same procedure for a MiniME™ or MultiScreen.*

2. Click **Key Fill** and select the video signal you want to use for the key.
3. Click **Chroma Key**.

*Tip: Click **Show Alpha** to have the preview output of the current ME switch to the alpha signal that is being used by the selected keyer. Show alpha is not available for MiniME™ outputs.*

4. Click **Advanced**.



5. Click the **Color** button for the color you want to key out.
6. Click **Init** to initialize the chroma key.  
Every time the key is initialized, the switcher resets all the Chroma Key parameters to their default settings.
7. Click an **Additive Keying** button to turn it on or off.
  - **Off** — Reduces the level of detail in the edges of the chroma key as well as the overall noise in the key image that can be the result of certain lighting conditions or high detail camera settings. This is the default setting.
  - **On** — Include the maximum detail in the edges of the chroma key.
8. Use the **Background Neg Hue** slider to adjust the range of hues that are included in the Background, expanding counter-clockwise around the color wheel.
9. Use the **Background Pos Hue** slider to adjust the range of hues that are included in the

---

Background, expanding clockwise around the color wheel.

10. Use the **Background Sat** slider to adjust the saturation range of the background color.
  - Increasing the saturation range value includes a wider range of saturation values to be included in the background.
  - Decreasing the saturation range value includes a narrower range of saturation values to be included in the background.
11. Use the **Edge Softness** slider to add or remove edge softening of the foreground image and alpha channel.
  - Increasing the softness value increases the amount of softness applied to the foreground edges and alpha channel.
  - Decreasing the softness value decreases the amount of softness applied to the foreground edges and alpha channel.
12. Use the **Foreground Clip** slider to adjust the foreground clipping.
  - Increasing the clip value removes lower-saturated colors from the Foreground image.
  - Decreasing the clip value includes lower-saturated colors in the Foreground image.
13. Use the **Foreground Hue** slider to select the central (base) color for the foreground.
  - Increasing the hue value moves counter-clockwise around the color wheel to select a base color.
  - Decreasing the hue value moves clockwise around the color wheel to select a base color.
14. Use the **Foreground Reject** slider to include or reject hues adjacent to the base color.
  - Increasing the reject value decreases the amount of adjacent hues that are included in the foreground.
  - Decreasing the reject value increases the amount of adjacent hues that are included in the foreground.
15. Use the **Background Suppress** slider to change the overall brightness of Shadow, Translucent, and Transition areas.
  - Increasing the background suppress value increases the brightness of

Background, Translucent, and Transition areas.

- Decreasing the background suppress value decreases the brightness of Background, Translucent, and Transition areas.
16. Use the **Luminance Reflection** slider to change the brightness of semi-transparent reflections (like reflections from glasses).
    - Increasing the reflections value increases the brightness of semi-transparent reflections.
    - Decreasing the reflections value decreases the brightness of semi-transparent reflections.
  17. Use the **Shadow Gain** slider to adjust the shadow appearance.
    - Increasing the gain value creates darker shadows.
    - Decreasing the gain value creates lighter shadows.
  18. Use the **Shadow Range** slider to adjust the range of the shadow colors.
    - Increasing the range value widens the shadow area by including lower-luminance background colors. The increased range comes as a result of colors moving from the translucent area to the shadow area.
    - Decreasing the range value narrows the shadow area by excluding high-luminance colors. These excluded colors move back into the translucent area.
  19. Use the **Spill Clip** slider to adjust spill suppress clipping.
    - Increasing the clip value removes higher-saturated colors from spill suppress correction.
    - Decreasing the clip value includes higher-saturated colors in spill suppress correction. If your foreground image contains bright-colored areas that are suffering from background spill, decrease the clip value to have it corrected.
  20. Use the **Spill Hue** slider to select the central, or base, color for spill suppress correction. If the color spill does not appear to be the same color as the background, use this



control to adjust which hue is considered to be "spilled" into the foreground.

- Increasing the hue value moves counter-clockwise around the color wheel while selecting a base color.
- Decreasing the hue value moves clockwise around the color wheel while selecting a base color.

**21.** Use the **Spill Reject** slider to include or reject adjacent hues to the base.

- Increasing the reject value increases the amount of adjacent hues that are included in spill correction.
- Decreasing the reject value decreases the amount of adjacent hues that are included in spill correction.

**22.** Use the **Transition Gain** slider to adjust the appearance of the Transition colors.

- Increasing the gain value makes the transition area pixels more opaque.
- Decreasing the gain value makes the transition area pixels more transparent.

**23.** Use the **Translucency Gain** slider to adjust the appearance of the translucent colors.

- Increasing the gain value causes the translucent colors to appear more opaque.
- Decreasing the gain value causes the translucent colors to appear more transparent.

**24.** Use the **Translucency Range** slider to adjust the range of the translucent colors.

- Increasing the range value widens the translucent area by including more hues from the background range (the lower-end of the range is defined by the shadow range you just set).
- Decreasing the range value narrows the translucent area by excluding hues.

**25.** Click **Mask** to apply a mask to the key.

## MiniME™ Chroma Key Output

You can use a MiniME™ to output a chroma key fill and alpha. This allows you to use the switcher as a chroma key generator for a virtual set environment.

## Keep the following in mind:

Keep the following in mind when setting up an external chroma key output.

- Only Key 2 from a MiniME™ can be used to output the video/fill of the chroma key. Key 1 must be set to black and off-air.
- All ancillary data is stripped from the video source.

## To Set Up a MiniME™ Chroma Key Output

The fill of the chroma key is fed out of the MiniME™ keyer and the alpha is fed out of the selected output.

*Note: This procedure uses MiniME™ 4 for the chroma key output, but you can use any MiniME™.*

1. Click **Navigation Menu > Live Assist > MEs > MiniME 4.**
2. Click **Key 1.**
3. Click **Key Fill:** and select **Black.**
4. Click **Key 2.**
5. Click **Key Fill** and select the video source that you want to chroma key.
6. Click **Chroma Key** and initialize the key as normal.
7. Click **Navigation Menu > Configuration > Outputs.**
8. Click the **Source** button for the output that you want to feed the chroma key fill from and click **MiniME4.**
9. Click the **Source** button for the output that you want to feed the chroma key alpha from and click **MMCKA4.**

## DVE Keys

The DVE key allows you to apply digital video effects, such as scale, crop, aspect ratio, position, and border to a video image or another key type. When the DVE is applied to another key type, it is said to be flying (Fly Key).

*Tip: You can see where DVE channels are allocated from the Status page in DashBoard.*

## Keep the following in mind:

Keep the following in mind when working with a Fly Key:

- The Fly Key feature consumes a single DVE channel for self keys and chroma keys, but two DVE channels for an auto select key.

- The Fly Key feature cannot be applied to a DVE key.
- The Key Invert feature is not available for a Fly Key.
- The self key Fly Key can be used with all MultiScreen layouts. The auto select key Fly Key can only be used with the Dual Vert or Dual Horiz MultiScreen layouts.
- A chroma key should be initialized and adjusted before the DVE (Fly Key) is applied to it.

## To Set Up a DVE Key

The DVE engine allows you to apply digital video effects, such as scale, crop, aspect ratio, position, and border to a video image in 2D space.

The DVE resources for this key may not be available. Depending on how your switcher is configured, you may be asked to steal the resources from another element, or be prevented from using the resources.

1. Click **Navigation Menu > Live Assist > MEs** and select the ME and key that you want to set up.

**Tip:** You can use the same procedure for a MiniME™ or MultiScreen.

2. Click **Key Fill** and select the video signal you want to use for the key.
3. Click **DVE**.



**Tip:** Click **Show Alpha** to have the preview output of the current ME switch to the alpha signal that is being used by the selected keyer. Show alpha is not available for MiniME™ outputs.

4. Use the **X-Position, Y-Position, and Size** sliders in the **Positioning** area to position and size the key.
5. Use the **Aspect** slider to adjust the aspect ratio of the key.
6. Use the **Left** and **Right** sliders to crop the left and right sides of the key.
7. Use the **Top** and **Bottom** sliders to crop the upper and lower sides of the key.
8. Click a **Freeze** button to freeze the video and appearance of the key (**On**). When a key is

frozen, the DVE attributes are disabled and you can not move the key.

9. Click **Mask** to apply a mask to the key.

Refer to the section [To Apply a Border/Edge Softness to a DVE Key](#) on page 41 for information on applying a border to the key.

## To Apply a DVE to a Key (Fly Key)

The Fly key is when the DVE engine is applied to another key type.

The DVE resources for this key may not be available. Depending on how your switcher is configured, you may be asked to steal the resources from another element, or be prevented from using the resources.

You should set up your key as you want it before applying the Fly Key.

1. Click **Navigation Menu > Live Assist > MEs** and select the ME and key that you want to set up.
2. Click **DVE** and click **On**.

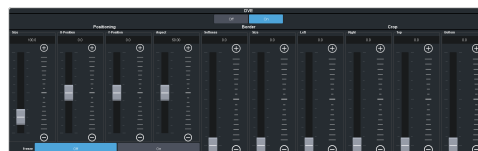

3. Use the **X-Position, Y-Position, and Size** sliders in the **Positioning** area to position and size the key.
4. Use the **Aspect** slider to adjust the aspect ratio of the key.
5. Use the **Size** and **Softness** sliders in the **Edge Softness** area to apply softness to the edges of to the key.

Refer to the section [To Apply a Border/Edge Softness to a DVE Key](#) on page 41 for information.

6. Use the **Left** and **Right** sliders to crop the left and right sides of the key.
7. Use the **Top** and **Bottom** sliders to crop the upper and lower sides of the key.
8. Click a **Freeze** button to freeze the video and appearance of the key (**On**). When a key is frozen, the DVE attributes are disabled and you can not move the key.

## To Apply a Border/Edge Softness to a DVE Key

A DVE border or edge softness is applied to the edges of the DVE key and is manipulated as part of the key.

**Note:** You can only apply a border to a DVE key. Fly Keys, such as chroma keys or auto select keys with DVE applied to them cannot have a border applied to them. Instead, the selection is Edge Softness and is used to soften the edges of the key without any color.

1. Click **Navigation Menu > Live Assist > MEs** and select the ME and key that you want to set up.

**Tip:** You can use the same procedure for a MiniME™ or MultiScreen.

2. Click **DVE**.

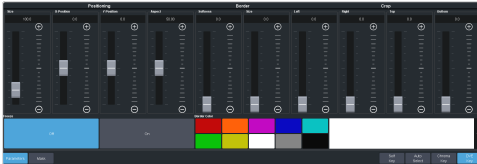

3. Use the **Size** slider in the **Border** area to turn on the border and adjust the size of the border around the key.
4. Use the **Softness** slider to adjust the softness of the border.
5. Select a default or custom color for the border (borders only).
  - **Default** — click one of the preset colors.
  - **Custom** — click the arrow to the right of the **Border Color** area and use the **Hue**, **Saturation**, and **Lightness** sliders to select your own color. Click **OK** to apply the color or **Live** to apply it in real-time.

## Show Alpha

You to route the processed alpha for the selected keyer to the preview output for the ME you are working on.

Show alpha is not available on a MiniME™ or MultiScreen.

- Select the keyer that you want to show the alpha for and press and hold the **SHOW ALPHA** button on the control panel. The preview output of the ME shows the processed alpha of the selected key until the button is released.
- Select the keyer that you want to show the alpha for and double-press the **SHOW ALPHA** button. The preview output of the ME shows the processed alpha of the selected key until the button is pressed again.
- Toggle the **Show Alpha** button on from the Live Assist.

## Masks

A Mask is a technique in which a pattern is combined with the key source to block out unwanted portions of the key source.

Two types of masks are available, Box masks and Pattern masks. All key types can be masked.

- **Box Mask** — uses a simple box shape to mask out a portion of the key
- **Pattern Mask** — uses a pattern from the pattern generator to mask out a portion of the key

### To Pattern Mask a Key

Pattern masks can be adjusted for size, location, rotation, and multiplication.

1. Click **Navigation Menu > Live Assist > MEs** and select the ME and key that you want to set up.

**Tip:** You can use the same procedure for a MiniME™ or MultiScreen.

2. Click **Mask > Pattern**.



3. Select the pattern you want to use for the mask.
4. Click **Mask Force** to force the area inside the mask region to the foreground.
5. Click **Mask Invert** to invert the masked area with the unmasked area.
6. Set up the mask pattern as required.
  - **Size** — adjust the size of the mask region.
  - **Softness** — apply softness to the edges of the mask region.
  - **Border Size** — apply a border to the mask region and adjust the size. At size 0 the border is off.
  - **Aspect** — adjust the aspect ratio of the mask. Not all patterns allow you to adjust the aspect.
  - **Rotation** — rotate the mask pattern. Not all patterns can be rotated
  - **H-Multiply** — multiply the mask pattern horizontally.
  - **V-Multiply** — multiply the mask pattern vertically.

- **X-Position** — position the mask on the x-axis.
- **Y-Position** — position the mask on the y-axis.

## To Box Mask a Key

Box masks can be adjusted for size, location, rotation, and multiplication.

1. Click **Navigation Menu > Live Assist > MEs** and select the ME and key that you want to set up.

*Tip: You can use the same procedure for a MiniME™ or MultiScreen.*

2. Click **Mask > Box**.



3. Click **Mask Force** to force the area inside the mask region to the foreground.
4. Click **Mask Invert** to invert the masked area with the unmasked area.
5. Set up the mask as required.
  - **Size** — adjust the size of the mask region.
  - **Left Edge** — adjust the position of the left edge of the mask region.
  - **Right Edge** — adjust the position of the right edge of the mask region.
  - **Top Edge** — adjust the position of the top edge of the mask region.
  - **Bottom Edge** — adjust the position of the bottom edge of the mask region.
  - **X-Position** — position the mask on the x-axis. This adjust both the left and right edges at the same time.
  - **Y-Position** — position the mask on the y-axis. This adjusts both the top and bottom edges at the same time.

*Tip: You can use the Positioner to adjust the size and position of the box mask.*

## Split Keys

A Split key allows you to assign a different alpha source for a key than the fill/alpha associations that are set up during configuration, or to use a separate alpha source for a Self key.

A split key can be applied to an auto select, or self key.

## To Set Up a Split Key

A split key works on an **Auto Select** or **Self Key** that has been set up and you want to apply a different alpha to.

1. Set up your key with the video source you want to use.
2. Click **Navigation Menu > Live Assist** and select the key you want split.

*Tip: From the control panel, press and hold the **SELF** or **AUTO** (depending on the type of key you are splitting) and press the source button for the new alpha you want to use.*

3. Click **Key Alpha** and select the new alpha you want to use.

# Memory Functions

A memory register is a snapshot of the current state of the switcher that can include one or multiple ME, MiniME™, MultiScreen, or chroma key outputs. Up to 100 memory registers per ME, MiniME™, MultiScreen, or chroma key can be stored and recalled on the switcher. Each of these memory registers can store as little as the information of one ME, or as much as the current state of the entire switcher, including all ME, MiniME™, MultiScreen, chroma key outputs, Aux Buses, and DVE settings.

## Storing Memories

When you store a memory, you are storing the complete state of that panel row. This includes the current state of all the areas on the ME, including keyer settings, transition rates, wipe and pattern selections, and source selections. In addition to the current state of the panel, the current settings for the various keyers, such as chroma key settings, and clip and gain settings, are also stored.

### To Store a Memory

How to store a memory.

1. Click **Navigation Menu > Live Assist > Memory > Store > General.**



2. In the **Inclusions** area, select the ME, MiniME™, and MultiScreen that you want to store the memory for. When you include an area in a memory, the current state of that area is stored in the memory and will be recalled with the memory.

*Tip: You can deselect all inclusions for a memory so that it doesn't affect these areas. This can be used to create a memory that only recalls Media-Store or Aux bus selections.*

3. In the **Memory Store** area, click the **Bank X** and **X:Mem** button for the bank and memory register that you want to store to.

*Tip: If a memory register contains a memory for the area(s) selected in the **Inclusions**, the button glows purple and the areas that the register contains a memory for are listed*

*below the memory number. The currently selected memory register glows blue.*

4. Select the recall mode for the memory. This is the mode that is stored in the memory, but can be overridden when the memory is recalled.
  - **Program** — all elements are recalled as stored (default).
  - **MemoryAI** — current on-air elements are unchanged and the transition area is configured to take the on-air elements of the memory on-air with the next transition.
  - **Effects Dissolve** — on-air elements listed below are transitioned to the elements stored in the memory. The time it takes to go from the current elements to the elements in the memory is set in the **Effects Duration** field.
    - Matte colors (background, wash or borders)
    - Keyer settings like clip, gain, transparency
    - Mask position and size
    - Chroma key settings, except the background color
    - Pattern settings like size, position, aspect, border, softness, rotation
    - DVE settings like size, position, aspect, border, softness, cropping
    - Media-Store x/y position
    - Transition Progress
5. Set the memory attributes that you want recalled with the memory. Refer to [Memory Attributes](#) on page 46 for information on memory attributes.

*Tip: All attributes are stored in the memory. Turning individual attributes on or off sets whether that item is included with the memory recall. Individual attributes can be turned on or off when the memory is recalled.*

6. Click **Store** to store the memory.

## Recalling Memories

When you recall a memory, the existing configuration of that ME is replaced with the settings stored in the memory.



## Keep the following in mind:

Keep the following in mind when recalling memories:

- How a memory is recalled depends on the how the Memory Attributes are set.
- Recalling a memory that includes a new Media-Store image to be loaded from a USB drive may result in the currently loaded image to be displayed for a few frames while the new image is loaded.
- Recalling a memory that includes a source assigned to a camera also recalls the shot stored in the memory for that camera if the **Camera** memory attribute is set to **Recall**. There is no delay in the memory recall so camera movement may be visible while the shot is recalled.
- You can override the video source stored in a memory by pressing and holding a source button and recalling the memory (Bus Hold). The held source button overrides the source that is recalled with the memory for that bus. The memory is not affected by a Bus Hold and will recall properly without the Bus Hold.
- Enabling Memory AI mode changes the way key elements are recalled. If a key is currently on-air, the element for that key is recalled in the next available off-air key. If there is no available off-air keys, the element is not recalled.

## Related information

[Memory Attributes](#) on page 46

## Memory Attribute Color Coding

For a memory recall you can set individual attributes to be recalled or not, regardless of how they were stored. How the attribute is recalled is indicated by the color of the attribute button.

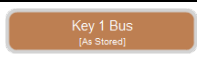
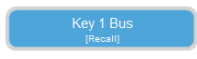
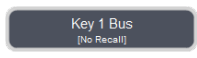
| Color   | Description  |
|---|--|
|  | <b>As Stored</b> — the memory attribute is recalled exactly as it was stored in the memory.  |
|  | <b>Recall</b> — the memory attribute is recalled with the memory, even if the attribute was not set to be stored with the memory.    |
|  | <b>No Recall</b> — the memory attribute is not recalled with the memory, even if the attribute was set to be stored with the memory. |

## To Recall a Memory

How to recall a memory using DashBoard.

1. Click **Navigation Menu > Live Assist > Memory > Recall > General**.



2. In the **Inclusions** area, select the ME, MiniME™, and MultiScreen that you want to recall the memory for.

*Tip:* You can deselect all inclusions for a memory so that it doesn't affect these areas. This can be used to create a memory that only recalls Media-Store or Aux bus selections.

3. In the **Memory Recall** area, click the **Bank X** button for the bank that you want to recall from.

**Important:** Clicking a **X:Mem** button recalls that memory.

*Tip:* If a memory register contains a memory for the area(s) selected in the **Inclusions**, the button glows purple and the areas that the register contains a memory for are listed below the memory number.

4. Select the recall mode for the memory.

**Note:** Recall attributes are color-coded for how they are going to be recalled. Refer to [Memory Attribute Color Coding](#) on page 45 for information on the color meaning.

- **As Stored** — recall the memory with the same attributes that it was stored with.
- **Program** — all elements are recalled as stored (default).
- **MemoryAI** — current on-air elements are unchanged and the transition area is configured to take the on-air elements of the memory on-air with the next transition.
- **Effects Dissolve** — recall the memory with an effects dissolve to the new memory elements. The time it takes to go from the current elements to the elements in the memory is set in the **Effects Duration** field or using the **Effect Duration From Memory**.

5. Set the memory attributes that you want recalled with the memory. Refer to [Memory Attributes](#) on page 46 for information on memory attributes.

**Note:** All attributes are stored in the memory. Turning individual attributes on or off sets whether that item is included with the memory recall. Individual attributes can be turned on or off when the memory is recalled.

- Click the **X:Mem** button to recall the memory.

**Tip:** Click **Undo** to undo the last memory recall.

## Memory Attributes

Memory Attributes allow you to specify what elements are recalled with a memory, as well as adding effects to memory recalls. These elements include the background/preset buses, keyer bus, Aux bus, and Media-Store selections, as well as keyer on-air status, and transition selections.

In addition to setting which sources to recall with the memory, effects such as performing an auto transition after the memory recall or running a custom control after the memory recall, can also be included.

Memory attributes can be set both when the memory is stored, and when it is recalled. This allows you to store a set of attributes with a memory and then recall it as stored, or override the attributes stored in the memory and apply different ones when the memory is recalled. A memory attribute does not need to be stored in the memory to be recalled.

**Tip:** It is recommended that if you are new to working with memories, use the memory store attributes to set how you want a memory to be recalled and set the recall attributes to be **Memory**.

### To Set the Memory Attributes

Memory attributes can be set when the memory is stored or when it is recalled. This procedure sets the store attributes, but the information applies to both.

- Click **Navigation Menu > Live Assist > Memory > Store**.
- Click **General** and set the attributes as required.



**Note:** For information on the recall mode (**Program/MemoryAI/Effects Dissolve**) refer to **To Store a Memory** on page 44.

- Roll GPO** — set whether GPI outputs attached to sources are triggered when recalled.
- Roll VTR** — set whether a play command is triggered when a source that is assigned to a video server is recalled.
- Roll PBus** — set whether a PBus trigger function is sent when a source that is assigned to a PBus device is recalled.
- Camera** — set whether camera shots are recalled.
- MediaX** — set whether Media-Store items and settings for the selected channel are recalled.

- Click **ME X**. The attributes for each ME are separate and must be set for each ME you want to include in the memory.



- Trans Area** — set how the next transition type and parameters are recalled.
- Next Trans** — set how the next transition area is recalled.
- Run Auto** — set whether a transition is performed after the memory is recalled. (Not available during Effects Dissolve transitions.)
- PGM Bus** — set how the sources selected on the program bus are recalled.
- PST Bus** — set how the sources selected on the preset bus are recalled.
- Shared Pattern** — set whether the settings for the shared Key Mask/Wash pattern generator is recalled.
- Key X Bus** — set whether the source selected on the key bus is recalled.
- Key X Active** — set whether the on-air status of the key is recalled.
- Key X Type** — set whether the key type is recalled.
- Key X Mask** — set whether mask settings for the key are recalled.

- Click **MiniMEs**.





- **Trans Area** — set how the next transition type and parameters are recalled.
- **Next Trans** — set how the next transition area is recalled.
- **Run Auto** — set whether a transition is performed after the memory is recalled. (Not available during Effects Dissolve transitions.)
- **PGM Bus** — set how the sources selected on the program bus are recalled.
- **PST Bus** — set how the sources selected on the preset bus are recalled.
- **Key X Bus** — set whether the source selected on the key bus is recalled.
- **Key X Active** — set whether the on-air status of the key is recalled.
- **Key X Type** — set whether the key type is recalled.
- **Key X Mask** — set whether mask settings for the key are recalled.

#### 5. Click **MultiScreens**.



- **Trans Area** — set how the next transition type and parameters are recalled.
- **Next Trans** — set how the next transition area is recalled.
- **Run Auto** — set whether a transition is performed after the memory is recalled. (Not available during Effects Dissolve transitions.)
- **PGM Bus** — set how the sources selected on the program bus are recalled.
- **PST Bus** — set how the sources selected on the preset bus are recalled.
- **Key X Bus** — set whether the source selected on the key bus is recalled.
- **Key X Active** — set whether the on-air status of the key is recalled.
- **Key X Type** — set whether the key type is recalled.
- **Key X Mask** — set whether mask settings for the key are recalled.

#### 6. Click **Auxes**.



- **Aux X** — set whether the source selected on the aux bus is recalled.

## Deleting a Memory

You can delete the contents of a single memory. Only one memory can be cleared at a time, and you cannot undo the deletion.

*Tip: You can clear all memories from the switcher from the control panel. (Press **MENU** > **Reset** > **NEXT** > **NEXT**.)*

### To Delete a Memory

Delete an individual memory or bank.

1. Click **Navigation Menu** > **Live Assist** > **Memory** > **Store**
2. In the **Memory Store** area, click the **Bank X** and **Mem X** button for the memory register that you want to delete.
3. Click **Delete Memory**.

## Memory Names and Mnemonics (TouchDrive only)

Assign custom mnemonic colors and names to individual memories. These are only visible on the TouchDrive panel when the user select bus is assigned to a memory bank,

### To Assign a Name to a Memory

Memories can have custom names and colors on the TouchDrive control panel.

1. Click **Navigation Menu** > **Live Assist** > **Memory** > **TouchDrive Mnemonics**.

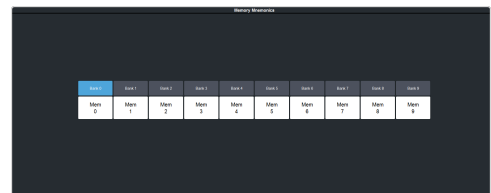

2. Click **Bank X** to select the bank that the memory you want to name is on.
3. Click the memory you want to name.

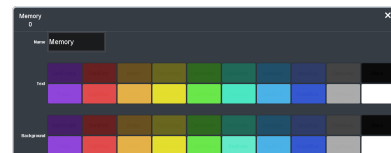

| Setting     | Description                               |
|-------------|---|
| <b>Name</b> | Enter a new name for the selected memory. |

---

| Setting    | Description   |
|------------|---|
| Text       | Click a <b>Foreground</b> button to select the color you want to apply to the text on the mnemonic.       |
| Background | Click a <b>Background</b> button to select the color you want to apply to the background on the mnemonic. |

# Switcher Sets

The switcher stores configuration and operation data in a number of registers that contain the individual entries for items such as memories or personality settings. These registers can be stored as a single archive file, or as a register set that contains all the individual register of that type; all memories for example. These files are stored into Sets on USB drive. Different Sets can be created for different shows or applications, allowing you to quickly locate and recall the switcher configurations.

The switcher stores information in the following registers:

- **Memory** — contains all the memories for ME, MiniME™, and MultiScreen.
- **Custom Control** — contains all the custom control banks and macros.
- **Personality** — contains all the user interface settings, such as transition rates, that are stored under the **Personality** menu. Some personality settings are specific to the control panel and can be stored independently if you are working with a MultiPanel system.
- **Installation** — contains all the external device setup, and software settings for the switcher.

## To Store a Set

Switcher Sets can only be stored to a USB drive. The USB drive must be present before you try to store the Set. A total of 10 Sets of switcher setup information can be stored onto the same USB drive.

*Note: If you are updating an older setup file, you must perform a Recall All followed by a Store All. This updates the setup files the latest format. You can then make changes and store to individual registers if needed.*

1. Insert a USB drive into the USB Port on the frame. You must wait 5 seconds for the switcher to recognise the USB drive.
2. Click **Navigation Menu > Configuration > System > Save Sets**.



3. Click a **Select Set** button for the set you want to store the switcher registers to.
4. Click a **Save** button to save that register to the selected set. If the button is shown in brown, that register already exists in the set and will be overwritten.
  - **All** — store all registers to the set.
  - **Memories** — store only the memory registers to the set.
  - **Customs** — store only the custom control registers to the set.
  - **Installation** — store only the installation registers to the set.
  - **Personality** — store only the personality registers to the set.

5. Click **Yes**.

The registers are stored to the set on the USB.

*Tip: You can export the switcher set to your local computer in the **Export Set From Frame** area. Click **Export As...** and navigate to the folder where you want to store the file and enter a name. Click **Save** and then **Export**.*

## To Load a Set

Switcher Sets can only be loaded from a USB drive. The USB drive must be present before you try to load the settings.

*Note: If you are updating an older setup file, you must perform a Recall All followed by a Store All. This updates the setup files the latest format. You can then make changes and store to individual registers if needed.*

1. Insert your USB drive into the USB Port on the frame. You must wait 5 seconds for the switcher to recognise the USB drive.
2. Click **Navigation Menu > Configuration > System > Load Sets**.

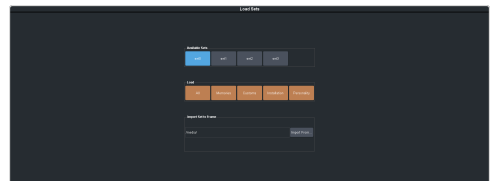

*Tip: You can import a switcher set from your local computer in the **Import Set to Frame** area. Click **Import From...** and navigate to the folder where the set is stored and click **Open**. Click **Import**.*

3. Click an **Available Set** button to select the set you want to load the switcher register from. If there is only one set on the USB then these buttons will not be present.

- 
4. Click a **Load** button to load that register.  
Only those registers that are present in the set are shown.
    - **All** — recall all registers from the set.
    - **Memories** — recall only the memory registers from the set.
    - **Customs** — recall only the custom control registers from the set.
    - **Installation** — recall only the installation registers from the set.
    - **Personality** — recall only the personality registers from the set.
  5. Click **Yes**.

---

## Media-Store

The MediaManager interface to the Media-Store allows you to load stills, animations, or audio files from the USB drive and make them available across all MEs. Two channels of Media-Store with alpha, or four channels without alpha, are provided.

*Tip: The legacy web version of MediaManager can still be accessed by using a Google Chrome™ web browser to navigate to the IP address of the frame.*

### Keep the following in mind:

Keep the following in mind when working with Media-Store:

- A still, animation, or audio can be loaded either by browsing the file system, or by entering the still number using the pattern buttons.
- You can clear a Media-Store channel by loading media number 000.
- If you are loading an Auto Key into a Media-Store channel, you must have another Media-Store channel associated with the current one to load the alpha into.
- An FTP connection using RossLinq can be created from an external device directly to a Media-Store channel on the switcher.
- If you delete a media item from the USB, you may have to load that media item into a Media-Store channel for the switcher to prompt you to delete the media item from the database.
- If you delete or rename a media item on the USB while it is still inserted into the switcher, you must attempt to load the old file to clear that entry from the database.
- The legacy web version of MediaManager still supports playlists.

## Working With Media-Store Animations

Media-Store animations can be used for animated backgrounds, branding "bugs", or media transitions. You can set up an animation to loop, play automatically when taken on-air, play in reverse, or even play at different speeds.

*Tip: You can play an animation manually from a control panel by selecting the source button for the Media-Store channel with the animation you want to play, and pressing **Run** on the 3-knob menu. The knob changes to **Stop** as the animation is playing.*

### Keep the following in mind:

Keep the following in mind when working with Media-Store animations:

- When you load an animation to an off-air Media-Store channel, or the animation goes off-air with a transition, the preview shows the cut point (**CutFr**) for that animation, and not the first frame of the video.
- You can manually cycle through frames by turning the **Run** knob while the animation is stopped.
- Double-pressing the **Run** knob stops playback and re-cues the animation to the first frame.
- You can shuttle forwards and backwards through the animation by turning the positioner clockwise or anti-clockwise when the animation is stopped, if your control panel has a positioner with a z-axis. Shuttle speed is increased and decreased by turning the positioner more or less in each direction.
- You can run or stop an animation by pressing the positioner button, if your control panel has a positioner with a button.

## Working With Media-Store Audio

Audio can be added to the playout of a Media-Store channel either by loading the file directly, or by naming the audio file the same as the animation or still you want it to play out with. When you load the still or animation, the switcher will automatically load the audio file of the same name.

### Keep the following in mind:

Keep the following in mind when working with Media-Store audio:

- Media-Store audio is available to the audio mixer and the AES outputs on the frame.
- Audio files must be 20-bit or 24-bit wav files at a 48kHz sample rate.
- Audio files must be in the same folder and have the same name as the still or animation they are to be associated with.
- An audio file does not need to be of the same length as the animation it is associated with.
- A still with audio or audio only have the Auto Play and Looping attributes. These apply to the audio playout.
- The looping time of an animation with audio is the length of the animation.

- A Media-Store channel can be loaded with Audio only.

## Media-Store File Specifications

Media items can be in TGA, PNG, or JPG file formats. For animations, the files must be numbered to indicate the order they go in, and the name and the number must be separated with an underscore. For audio, 20-bit or 24-bit WAV files of the same name as the still or animation are used to associate audio with a still or animation.

For example, the following files are treated as a single animation named Anim that is 100 frames long:

- Anim\_001.tga
- Anim\_002.tga
- Anim\_003.tga
- ...
- Anim\_100.tga

**Note:** Media items must be created in the same color gamut and dynamic range that they are intended to be used in on the switcher. If a media item is created in one color space and the switcher is operating in another, the media item may not appear correctly.

**Note:** An animation must start with `_001` at the end of the name of the first frame.



**Important:** Files names cannot contain symbols such as `! @ # & * ( ) / , ? ' "`  and cannot start with an underscore (`_`).

## Loading Stills or Animations

Stills or animations can be loaded into Media-Store channels from the USB by navigating to the file in MediaManager. MediaManager creates and maintains a database of the media items on the USB, as well as the setting for each media item and a thumbnail.

**Note:** The internal cache is used for sample images only and cannot be used to store user stills or animations.

### To Load a Media Item

Media items are loaded from the USB drive into a Media-Store channel from MediaManager

**Note:** Media items must be created in the same color gamut and dynamic range that they are intended to be used in on the switcher. If a media item is created in one color space and the switcher is operating in another, the media item may not appear correctly.

1. Insert your USB drive into the USB Port on the switcher. You must wait 5 seconds for the switcher to recognise the USB drive.

If the files on your USB are new, it takes about 2 seconds per file for the switcher to generate the thumbnail for the MediaManager. Once all the thumbnails are generated, they are displayed in the MediaManager window.

2. Click **Navigation Menu > MediaManager**

**Tip:** The MediaManager can also be accessed from Live Assist (Click **Navigation Menu > Live Assist > Media > MediaManager**). The Live Assist version follows Media-Store source selections on the panel.

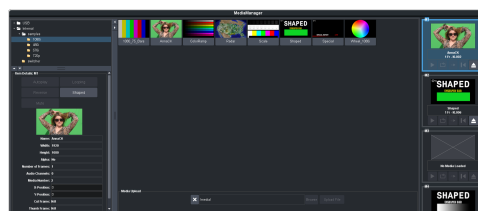



3. Navigate to the folder containing the media item you want to load into a Media-Store channel.

**Note:** The first time you navigate to a folder it may take a few moments for the Media-Store to scan the files and build the database entries.

**Tip:** You can upload a media item from your computer to the selected folder on the USB. In the **Still Upload** area click **Browse** and navigate to the media item you want to upload to the USB. Click **Open** and then **Upload File**.

All the media items in that folder are shown in the center area of the page.

4. Drag the media item onto the Media-Store channel you want to load it in.

**Tip:** The film-strip symbol () indicates that the media item is an animation, the key symbol () indicates that the media item has an alpha, and the speaker symbol () indicates that the media item has audio associated with it, or is audio only.

## MediaManager Channel Control

Once a media item is loaded into a channel you can control the playout for the media item from MediaManager.

**Note:** Playlists are not supported by MediaManager in DashBoard at this time.



**Tip:** The background of the channel areas tallies the on-air status of the Media-Store channel. Red for on-air and green for on-preview.

The label below the thumbnail of the media item shows the name of the file, the number of frames in the animation, and the media ID. In this example, the name of the media item is **Lobster**, it is **5** frames long, it is located on the USB (**U1**) and has a media ID of **001**.

The controls below the name allow you to set how the animation plays out as well as eject the current media item.

- **Play** — play the animation.
- **Loop** — set the animation to start playing again from the beginning when it reaches the last frame.
- **Play Direction** — set the animation to play in the forward or reverse direction.
- **Re-cue** — re-cue the animation to the first playout frame.
- **Eject** — eject the current media item from the channel.

## Media-Store Attributes

Attributes are applied to the media item in the database and in each Media-Store channel. Where the attributes are being applied is shown in the upper left corner of the area. If you adjust the attributes of the media item in one channel, these settings are not applied back to the database or to other channel if the same media item is loaded into more than one channel.

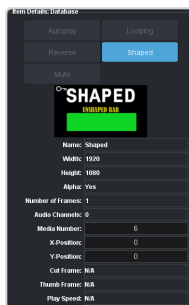

**Tip:** At the top of the **Item Details** frame the title indicates if the information shown applies to the media item loaded into the media channel (**MX**), or is from the media item in the database (**Database**).

### Buttons:

- **Autoplay** — play the animation automatically when the Media-Store channel is taken on-air.
- **Reverse** — set the animation to play in the forward or reverse direction.
- **Mute** — mute the audio associated with the media item.
- **Looping** — set the animation to start playing again from the beginning when it reaches the last frame.
- **Shaped** — set the alpha to be shaped, or unshaped when not selected.

### Fields:

- **Name** — the name of the media item as taken from the file name.
- **Width** — the width of the media item raster.
- **Height** — the height of the media item raster.
- **Alpha** — shows whether there is an associated alpha with the media item.
- **Number of Frames** — the number of frames in the animation.
- **Audio Channels** — the number of audio channels in the associated audio.
- **Media Number** — the media number of the media item.
- **X-Position** — set the horizontal position of the media item.
- **Y-Position** — set the vertical position of the media item.
- **Cut Frame** — set the frame of the animation when used as part of a MediaWipe.
- **Thumb Frame** — set the frame of the animation that is used for the thumbnail.
- **Play Speed** — set the playout speed for the animation.

## Media-Store Capture

Still images can be captured from any input BNC, as well as the program, preview, and clean feed from any ME.

### To Capture a Still From the Panel



**Important:** A control panel is required to perform this procedure. If you do not have access to a physical control panel, the SoftPanel can be used. The position of items on the menus on the SoftPanel may not match those of a physical panel.

1. Insert your USB drive into the USB Port on the switcher. You must wait 5 seconds for the switcher to recognise the USB drive.

- 
2. Press the source button for the Media-Store channel that you want to capture a still into.
  3. Press the **Capt** knob.
  4. Press the **P/B** or **E/E** knob to select the mode you want the Media-Store in.
    - **E/E** — electronic-to-electronic, or record, mode allows you to record a still
    - **P/B** — playback mode allows you to review your still
  5. Use the **P/B** or **E/E** knob to select the video source that you want to perform the capture of.
  6. Press **NEXT**.
  7. Use the **Alpha** knob to select whether you want to capture the alpha signal (**Yes**) or not (**No**). You must have an input BNC selected as the capture source to capture the alpha.
  8. Press **NEXT**.
  9. Use the **Capt** knob to select a number for the still you want to capture.
  10. Press the **Capt** knob to perform the capture. The new media item is stored and the media number is increased by one.



# Custom Controls

Once programmed, a custom control (CC) can be played back by pressing a button. The custom control can be as simple as triggering an output GPI pulse, or as complex as recalling a specific memory register on an ME, performing a switcher transition, and selecting a group of keys.

You can record, edit, and run custom controls from the Custom Control node in Dashboard.

Refer to [Custom Control Events](#) on page 106 for information on available events.

## Recording/Editing Custom Controls

When you create a custom control, you record a series of events and special functions, that are played back when you run the custom control. The process for creating a new cc and editing an existing one are the same, except when editing you have the option to insert events at different points in the existing cc.

**Tip:** Remember that some functions take time to perform and a pause should be added after the function to ensure that the command is completed before moving on to the next command.

Almost any action or setting can be stored in a custom control, with the following exceptions:

- Diagnostic Functions
- Confirmation Dialogs
- Panel-Specific Functions

**Note:** It is recommended that you use a control panel for recording custom controls.

### To Record a Custom Control

A basic custom control records a series of events that are played out in the same order they are recorded.

1. Click **Navigation Menu > Custom Control > Editor**.

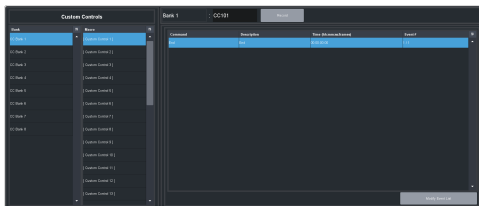

2. Click a **Bank** button to select the bank that the custom control you want to record will be stored on.

3. Click a **Macro** button to select the custom control that you want to record to. If the custom control already has a macro recorded, the name of the custom control is shown in the list.
4. Click **Record**.

**Tip:** The switcher can be set so that each command is automatically separated from the previous command by a pause equal to the real-time delay between the you entering commands. Press **CC/UP > NEXT > NEXT** and use the **CCPause** knob to select whether pauses are added automatically (**Record**) or no pauses are added (**Manual**).

The **CC/UP** button on the control panel, as well as the button assigned to the CC on the bus, flash red when the CC is recording.

5. Insert the events you want to record. Events can be entered from the menu or from actions directly on the control panel.

Each custom control can have a maximum of 998 events, plus the End event.

**Note:** When the switcher runs a custom control, it attempts to execute each event in the custom control as quickly as possible. If an event takes time to complete, the event may not be complete before the switcher attempts to execute the next event. For example, if your custom control has a memory recall followed by a transition, a pause should be added between the memory recall and the transition to ensure that the memory is fully recalled before the transition is performed. The same applies if you want to add events after a transition.

6. Click **Stop Recording** to finish recording.

**Tip:** Click **Cancel** if you do not want to store your events to the custom control.

### To Edit a Custom Control

When editing a custom control, you can delete and insert events at any point in the custom control, or append events to the end.

**Tip:** When editing a custom control, press **Run Event** to run the currently selected event. This can help you diagnose problems in a custom control.

1. Click **Navigation Menu > Custom Control > Editor**.

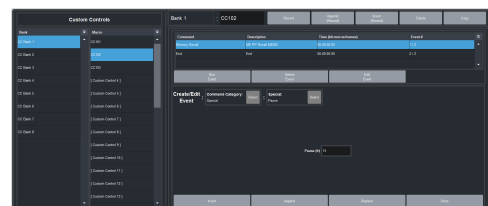

2. Click **Bank X** to select the bank that the custom control you want to edit is on.

3. Click the custom control that you want to edit.
4. Click the event that you want to edit or insert an event before.  
Refer to [Custom Control Events](#) on page 106 for information on available events.
5. Edit the custom control or event.
  - **Append (Record)** — start inserting events to the end of the custom control
  - **Append** — insert the current event at the end of the custom control
  - **Copy** — copy the entire custom control
  - **Delete** — delete the entire custom control
  - **Delete Event** — delete the currently selected event
  - **Edit Event** — edit the parameters of the currently selected event
  - **Insert (Record)** — start insert events after the currently selected event
  - **Insert** — insert the current event after the currently selected event
  - **Record** — start recording a new custom control over the existing one
  - **Run Event** — run the currently selected event

## Running a Custom Control

Once a custom control has been programmed, you can run that custom control by pressing the button that the custom control was recorded to.

### Keep the following in mind:

Keep the following in mind when running custom controls:

- A custom control will continue to run until it reaches a hold event, is stopped by another custom control, you edit a custom control, or the custom control reaches the end.
- When a custom control is running, the button on the custom control bus is red.
- When a custom control is held (at a Hold event), the button on the custom control bus flashes white.
- You can run multiple custom controls at the same time. The number of running custom controls is shown on the display when in custom control mode.
- You can stop a running custom control by pressing the red custom control button on the custom control bank.

- You can stop all running custom controls by selecting a custom control with no events recorded to it.
- A maximum of 128 custom controls can be run at the same time.

## To Run a Custom Control

Once a custom control has been recorded, you can run that custom control at any time.

1. Click **Navigation Menu > Custom Control > Shot Box**.

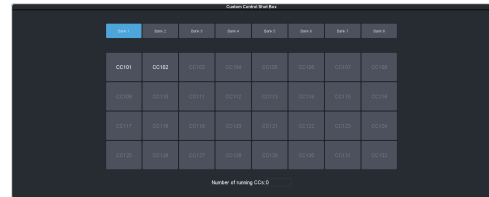

*Tip: You can also run a custom control directly from the control panel.*

*Tip: The number of custom controls that are currently running is shown at the bottom of the page.*

2. Click **Bank X** to select the bank that the custom control you want to run is on.
3. Click a custom control button to run that specific custom control.  
The custom control starts to play immediately.

## Naming Custom Controls

Each custom control can be given a unique name and mnemonic color. The name and color is shown on the custom control button.

### To Name a Custom Control

The procedure to name or rename a custom control is the same.

*Tip: You can also name a custom control from the Editor page.*

1. Click **Navigation Menu > Custom Control > TouchDrive Mnemonics**.

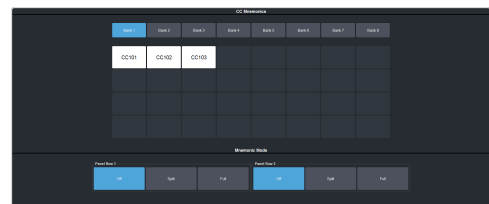

2. Click **Bank X** to select the bank that the custom control you want to name is on.

3. Select how you want the mnemonics on each panel row to display the mnemonics for custom controls.
  - **Off** — the mnemonics don't change when the row is assigned to a custom control bank.
  - **Split** — the mnemonics are split (top to cc name and bottom to bus sources) when the row is assigned to a custom control bank.
  - **Full** — the mnemonics are show only the names of the custom controls when the row is assigned to a custom control bank.
4. Click the custom control that you want to name.

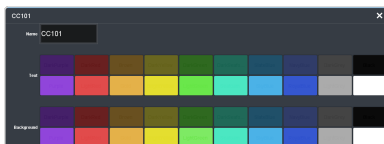

| Setting           | Description   |
|-------------------|---|
| <b>Name</b>       | Enter a new name for the selected custom control.   |
| <b>Text</b>       | Click a <b>Foreground</b> button to select the color you want to apply to the text on the mnemonic.       |
| <b>Background</b> | Click a <b>Background</b> button to select the color you want to apply to the background on the mnemonic. |

## Deleting Custom Controls

Any custom control on the switcher can be deleted to remove unused customs to free up space for new custom controls.

### To Delete a Custom Control

Deleting a custom control from the switcher.

There is no undo for this delete function.

1. Click **Navigation Menu > Custom Control > Editor**.
2. Click **Bank X** to select the bank that the custom control you want to delete is on.
3. Click the custom control button that you want to delete.
4. Click **Delete**.
5. Click **Delete** to delete the custom control.

## Copying and Pasting Custom Controls

The contents, or events, of a custom control can be copied from one custom control and pasted to another. Along with the events, the name and mnemonic settings are also copied.

### To Copy and Paste a Custom Control

Copy the contents of a custom control from one button to another.

1. Click **Navigation Menu > Custom Control > Editor**.
2. Click **Bank X** to select the bank that the custom control you want to copy is on.
3. Click the custom control that you want to copy.
4. Click **Copy**.
5. Select the custom control that you want to paste into.

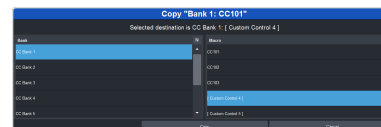

6. Click **Copy**.

# Network Connections

The switcher requires a network connection for the DashBoard interface as well as any control panel you want to use.

DashBoard can be run on a remote computer, or from the TouchDrive control panel. The Carbonite Black control panels still require a separate DashBoard computer.

**Note:** Refer to the documentation that came with DashBoard or your control panel for setup information.

The switcher uses the following network ports:

- **FTP** — 21
- **SSH** — 22
- **DashBoard** — 5253
- **SLP** — 427
- **Web Server** — 80
- **RossTalk** — 7788

## Network Setup

The frame comes from the factory set with a static IP address ( 192.168.0.123 ) but can be set to use DHCP to automatically obtain an IP address or to a different static IP address. You must connect to the frame from DashBoard to set a different static IP address.

**Note:** If you use a DHCP server, it must be set to always give the frame the same IP address. DashBoard and the control panel need a fixed IP address to connect to.

**Tip:** If you do not know the IP address of the frame, you can set DIP switch 1 on the frame to set the IP address to 192.168.0.123 . The frame must be re-started for the new IP address to be applied. Remember to set the DIP switch back once you have set the new IP address.

### To Connect DashBoard to the Frame

DashBoard connects to the frame as the master panel, or as a satellite panel. Connecting as a master or satellite panel is selected by the port used to connect to on the frame. All DashBoard connections and physical panels that connect on the same port mirror each other.

**Note:** DashBoard must be running on a computer/panel on the same subnet as the frame to connect.

You need the IP address of the frame to connect to it from DashBoard.

1. Click **File > New > TCP/IP DashBoard Connect or openGear Device**.

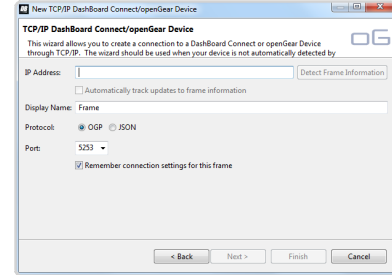

2. In the **IP Address** field, enter the IP address of the frame. The default IP address is 192.168.0.123 .
3. In the **Display Name** field, enter the name you want to use to identify the frame in DashBoard. This should be a unique name for the frame you are setting up.
4. Select **OGP**.
5. In the **Port** field, enter the port you want to connect to on the frame. The port you connect to assigns the relationship the DashBoard connection has to the frame.

**Tip:** Multiple DashBoard connections can use the same port, but they will mirror each other. For example, you can connect a control panel and a separate DashBoard computer to the Master Panel port to give control from the panel and DashBoard.

- **Master Panel** — 5253
- **Satellite 1** — 5255
- **Satellite 2** — 5256
- **Satellite 3/SoftPanel** — 5257

**Tip:** Refer to [MultiPanel](#) on page 98 for information on setting up a MultiPanel system.

6. Click **Finish**.  
The frame appears in the **Tree View**.

### To Change the IP Address

Change the IP address of the frame from DashBoard.

1. Click **Navigation Menu > Configuration > Network**.



2. Enter a name in the **Switcher Name** field. This is the name that appears in the tree view in DashBoard.
3. Click **Edit**.

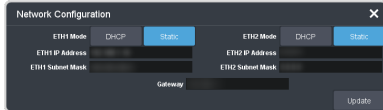

4. Click a **Mode** button to use DHCP (**DHCP**), or a static IP address (**Static**) for the ethernet port you are using.
5. For a static IP address, enter the IP address (**IP Address**), subnet mask (**Subnet Mask**), and gateway (**Gateway**) you want to use.
6. Click **Update**.

- user – used to create a connection to the general storage folders on the switcher, as well as any USB drive installed in the switcher

4. Enter the password password

## FTP Connection

You can create a File Transfer Protocol (FTP) connection from a computer to your switcher. You can use the FTP connection to copy still images and animations to and from your switcher as well as copy Edit Decision List (EDL) files from your switcher.

The procedure for creating an FTP connection from a computer varies between operating systems and client software. Consult with the documentation that came with your computer for assistance with creating an FTP connection.

*Tip: The FTP connection can be used to copy media items onto the USB that is installed in the switcher.*

### To Create an FTP Connection

This procedure applies to Microsoft® Windows XP® Professional and Windows® 7.

1. On your computer launch Windows Explorer.
2. In the address bar, type `ftp://IP Address of your switcher`. You are prompted for a username and password.
3. Type the user name for the application your are creating an FTP connection for. Each application has specific requirements. The switcher will set these requirements automatically based on the username.
  - `xpression` – used when creating a connection from a Ross® XPression Motion Graphics System directly to the Media-Store channels on the switcher, as well as any USB drive installed in the switcher
  - `liveedl` – used to create a connection to the LiveEDL folder on the switcher to download an edit decision list file form the switcher

# Video Reference

The flexible reference system in the switcher allows you to use an Interlaced video format as the reference to operate the switcher in a video format of the same frequency. Choosing a progressive video format as a reference limits you to operating the switcher only in that same video format and frequency. For example, if you have a 1080i 59.94Hz input reference you can operate the switcher in 720p 59.94Hz, but not 1080i 50Hz. However, if you have a 720p 59.94Hz input reference, you can only operate the switcher in 720p 59.94Hz.

## Supported Reference Formats

The switcher supports a number of reference modes for both internal and external reference signals. References to 1080p 59.94Hz (A) and 1080p 50Hz (A) refer to 1080p Level A only.

| Switcher Format   | Required Reference |
|-------------------|--------------------|
| <b>SD Formats</b> |                    |
| 480i/480i 16:9    | 480i               |
|                   | 1080i 59.94Hz      |
| 576i/576i 16:9    | 576i               |
|                   | 1080i 50Hz         |
| <b>HD Formats</b> |                    |
| 720p 50Hz         | 576i               |
|                   | 720p 50Hz          |
|                   | 1080i 50Hz         |
| 720p 59.94Hz      | 480i               |
|                   | 720p 59.94Hz       |
|                   | 1080i 59.94Hz      |
| 1080i 50Hz        | 576i               |
|                   | 1080i 50Hz         |
| 1080i 59.94Hz     | 480i               |
|                   | 1080i 59.94Hz      |
| 1080pSF 23.98Hz   | 1080pSF 23.98Hz    |
| 1080pSF 25Hz      | 576i               |
|                   | 1080i 50Hz         |
|                   | 1080pSF 25Hz       |
| 1080pSF 29.97Hz   | 480i               |
|                   | 1080i 59.94Hz      |
|                   | 1080pSF 29.97Hz    |

| Switcher Format | Required Reference |
|-----------------|--------------------|
| 1080p 25Hz      | 576i               |
|                 | 1080i 50Hz         |
|                 | 1080p 25Hz         |
| 1080p 29.97Hz   | 480i               |
|                 | 1080i 59.94Hz      |
| 1080p 50Hz      | 576i               |
|                 | 720p 50Hz          |
|                 | 1080i 50Hz         |
|                 | 1080p 25Hz         |
| 1080p 59.94Hz   | 480i               |
|                 | 720p 59.94Hz       |
|                 | 1080i 59.94Hz      |

The switcher allows you to use any interlaced video format to operate the switcher in any format of the same frequency; however, the use of 480i or 576i (Composite Sync) reference signals for High Definition (720p, 1080i, or 1080p) video modes is not recommended.

The use of composite sync reference formats is recommended for Standard Definition video modes only, and provides stable outputs with jitter performance in compliance with SMPTE-259M specifications.

## Reference and Video Mode Setup

The switcher supports both internal and external references. An external reference is provided by an external device to the switcher through the **REF IN BNC** on the frame. An internal reference is generated by the switcher and can be fed out to other devices.

The switcher automatically detects the reference signal and only shows the video modes that you can operate the switcher in that are supported for that reference format.

### To Set a Video Mode

The Vid Mode is the video format that the switcher is operating in.

If you are using an external reference, ensure that a proper reference is connected to the **REF IN** input BNC on the frame.

**Note:** You must use an interlaced reference source to have the switcher operate in an interlaced reference format if you are using an external reference.



1. Click **Navigation Menu > Configuration > Reference.**

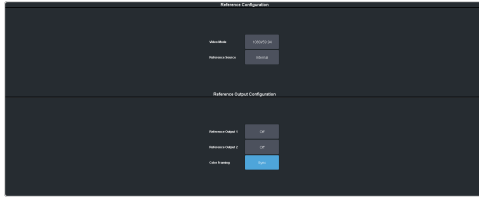

2. Click the **Video Mode** button and select the video format you want to use.  
The available video modes depends on the reference format coming into the switcher.
3. Click the **Reference Source** button and select an **Internal** or **External** reference source.

## Output Reference Synchronizers

The output reference synchronizers allow you to have the switcher output a reference signal that other devices, such as cameras and video servers, can lock to.

**Note:** Different applications require different output reference formats and delay settings. Consult a facility engineer for assistance in configuring these settings.

### To Set Up an Output Reference Sync

The reference output allows the switcher to provide a reference signal to other upstream or downstream devices. If the switcher is using internal reference, this reference signal can be sent to other devices so that all your equipment is synced to the same reference.

1. Click **Navigation Menu > Configuration > Reference.**

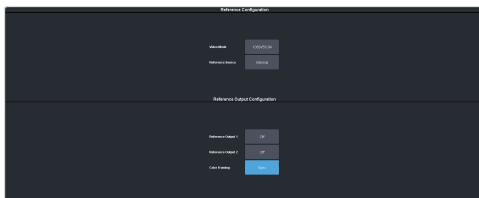

2. Click on the **Reference Output X** button for the reference output BNC that you want to set up.
3. Click on the reference format you want to output from the switcher.

The available output reference formats depend on the video format that the switcher is operating in. You must be in a 50Hz video format for PAL and a 59.94Hz video format for NTSC.

4. Select the type of delay you want to apply to the reference signal.

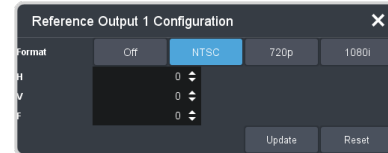

- **V** — vertical delay in lines
  - **H** — horizontal delay in pixels
  - **F** — frame delay in frames (NTSC/PAL only)
5. Click **Update.**
  6. Click **Yes** to assign the output reference synchronizer.
  7. If you select an analog reference format (NTSC/PAL) you must set whether you want to use color framing for the reference output (**Sync**) or not (**No Sync**).

## Switching Field

The switching field is the field in an interlaced video format that the switcher uses to transition from one video source to another. An interlaced video format is made up of two fields, field 1 (odd lines) and field 2 (even lines).

**Note:** If you are running in a progressive video format, selecting an even or odd fields will cause the switcher to only allow transitions on every second frame.

### To Set the Switching Field

Set the field that transitions are performed on.

**Note:** If you are using a Frame Sync or Format Conversion (FSFC), transitions are locked to Field 1.

1. Click **Navigation Menu > Configuration > System > Global.**



2. Click a **Field Dominance** button to select which field video transitions occur on.
  - **Field 1** — transitions occur on the odd field
  - **Field 2** — transitions occur on the even field
  - **Both** — transitions occur on the current field, either even or odd



---

# Switcher Modes

The switcher mode allows you to set the features and resources that you want to have available on your switcher. Some feature and resources are not compatible with all switcher modes.

*Note: The switcher mode can only be set from the control panel.*

**Table 1: Switcher Mode Features**

| Features   | Standard Mode | DVE Mode |
|--|---------------|----------|
| <b>Carbonite Black</b>                               |               |          |
| • DVEs   | 4             | 8        |
| • FSFCs (fixed)                                      | 6             | 0        |
| <b>Carbonite Black+ (only has one switcher mode)</b> |               |          |
| • DVEs   | 8             |          |
| • FSFCs  | 36            |          |

## Keep the following in mind:

### Keep the following in mind when changing switcher modes:

- The switcher supports synchronized and unsynchronized 1080p and 1080i inputs. The 1080i inputs are converted using a 4-line interpolator and may result in lower quality video.
- In the standard mode on Carbonite Black, the FSFCs are fixed to the first 6 input BNCs.

## To Set the Switcher Mode

*Note: Not all switcher support all modes. A restart is required to put the switcher into the new mode.*

1. Click **Navigation Menu > Configuration > System**.
2. Click the **Switcher Mode** button for the mode you want the switcher to operate in.
  - **Standard** — fixed FSFCs and limited number of channels of 2D DVE.
  - **DVE** — max number channels of 2D DVE channels.

# Video Inputs

External video sources come into the switcher through the input BNCs, and internal sources are generated internally from the switcher. Depending on how you want to use these video sources, or where they come from, you may want the switcher to pair them together, or associate an external device with them. Pairing two video sources together is usually used for an auto select key where an external device, such as a character generator, outputs both a key video and key alpha. Associating a video source with an external device allows special control over that device to become active when you select the source on a bus.

## Video Input Setup

Video inputs are separated into external sources and internal sources. The external sources are the video inputs coming in on the BNC and the internal sources are generated internally from re-entries or follows, or from media generators.

### To Set up an External Video Input

External sources come into the switcher from other devices, such as cameras, video servers, or character generators.

Click **Navigation Menu > Configuration > Inputs > External**

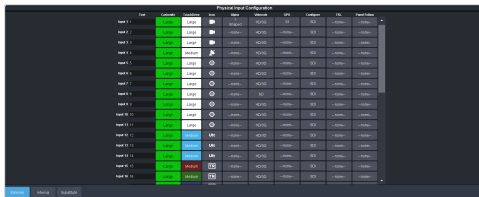

The physical inputs are listed along the side and the various settings are listed across the top. Click the setting button for the source you want to set up to view the available settings.

| Setting           | Description  |
|-------------------|--|
| <b>Text</b>       | Apply a custom name to the source. Enter a new name for each input you want to identify differently. The name is used to identify the input on the panel mnemonics and well as on menus. If TSL id is associated with the input, the switcher will use the router mnemonic name over the internal one. |
| <b>Carbonite</b>  | Set up the mnemonic appearance of the source for the control panel you are using. Refer to your control panel documentation for more information on setting up mnemonics.  |
| <b>TouchDrive</b> |  |
| <b>Icon</b>       |  |

| Setting             | Description  |
|---------------------|--|
| <b>Alpha</b>        | Link an alpha video feed to the video. If the input is the video or fill for an auto key, click the <b>Alpha</b> button and select the video source you want to use as the alpha. Refer to <a href="#">To Set Up an Auto Key Association</a> on page 66 for information on setting up an auto key.   |
| <b>Vidmode</b>      | Video inputs needs to be identified as being either SD or HD/3G so that they can be properly processed. Refer to <a href="#">Video Input Format Type</a> on page 64 for information on setting the input video mode.   |
| <b>GPO</b>          | Assign a GPI output to a video input. The GPI output is triggered with or before the source is taken on-air, depending on the <b>Predelay</b> setting. The GPI output can be used to trigger a video server to play before taking the server on-air. Refer to <a href="#">GPI Device Control</a> on page 66 for information on assigning a GPI output to a video source. |
| <b>Configure</b>    | Assign an FSFC or Delay to the input. Refer to <a href="#">Frame Sync and Format Conversion</a> on page 78 for information on FSFC setup.  |
| <b>TSL</b>          | Assign a TSL id to the input and set the tally state. Refer to <a href="#">To Assign a TSL ID to a Video Input</a> on page 64 for information on assigning a TSL id to an input.   |
| <b>Panel Follow</b> | Select one of the custom panels to be shown on Live Assist when the source is selected. This can be used to have the DashBoard page for a camera control unit displayed when the camera source is selected. Refer to <a href="#">Custom Page Auto Follow</a> on page 67 for information on setting up custom panels.   |

### To Set up an Internal Video Input

Internal sources are generated inside the switcher, such as matte backgrounds, Media-Store channels, and ME re-entries.

Click **Navigation Menu > Configuration > Inputs > Internal**



The internal sources are listed along the side and the various settings are listed across the top. Click the setting button for the source you want to set up to view the available settings.

| Setting             | Description  |
|---------------------|--|
| <b>Text</b>         | Apply a custom name to the source. Enter a new name for each input you want to identify differently. The name is used to identify the input on the panel mnemonics and well as on menus.   |
| <b>Carbonite</b>    | Set up the mnemonic appearance of the source for the control panel you are using. Refer to your control panel documentation for more information on setting up mnemonics.  |
| <b>TouchDrive</b>   |  |
| <b>Icon</b>         |  |
| <b>Alpha</b>        | Link an alpha video signal to the video. The Media-Store channels have dedicated alpha channels that cannot be changed. Refer to <a href="#">To Set Up an Auto Key Association</a> on page 66 for information on setting up an auto key.   |
| <b>GPO</b>          | Assign a GPI output to a video input. The GPI output is triggered with or before the source is taken on-air, depending on the <b>Predelay</b> setting. The GPI output can be used to trigger a video server to play before taking the server on-air. Refer to <a href="#">GPI Device Control</a> on page 66 for information on assigning a GPI output to a video source. |
| <b>Panel Follow</b> | Select one of the custom panels to be shown on Live Assist when the source is selected. The pages for MediaManager are assigned to the Media-Store sources. Refer to <a href="#">Custom Page Auto Follow</a> on page 67 for information on setting up custom panels.   |

## Video Input Format Type

Video inputs needs to be identified as being either SD or HD/3G so that they can be properly processed.

### To Configure The Input Format Type

Set the format type for each input as being SD or HD/3G.

1. Click **Navigation Menu > Configuration > Inputs > External**.
2. Click the **Vidmod** button for the input that you want to set the format type for and select the format type that is coming in on that input.

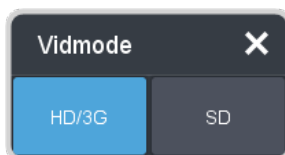

- **HD/3G** — select this option if the input video is in any 720p, 1080i, or 1080p format.

- **SD** — select this option if the input video is in any 480i or 576i format.

## Source Names

Each video source in the switcher can be given a unique name. These names can be customized for how they appear on the mnemonics by adjusting the size or the font and the background color.

*Note: If a TSL ID is assigned to a source, the switcher overwrites the source name on the MultiViewer and mnemonics with the TSL name. If there is no TSL name, or it has not been received yet, the source name is blank. For the labels on the MultiViewer, a combination of the TSL name and switcher source name are used. The new TSL name is passed from the switcher to any downstream TSL devices.*

### To Set Up a Source Name

Source names appear on mnemonics, menus, and on the MultiViewer.

*Note: Source names are restricted to eight characters in length.*

1. Click **Navigation Menu > Configuration > Inputs > External** if you are setting up a physical input, or **Internal** if you are setting up an internal input.
2. Enter a new name in the **Text** field for the video input that you want to name.

### To Assign a TSL ID to a Video Input

Pass router mnemonic names to the switcher with TSL ID data.

The switcher accepts incoming TSL data on TCP port 5727.

1. Click **Navigation Menu > Configuration > Inputs > External**

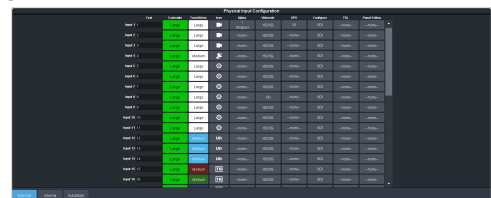

2. Click the **TSL** button for the input you want to assign a TSL ID to.

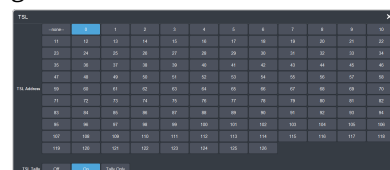

3. Click TSL ID number that you want to assign to the selected input BNC.
4. Click the **TSL Tally** button and select how the sources are tallied and which mnemonic name is use.
  - **Off** — TSL tally information for the selected ID is ignored. TSL mnemonic source names are used.
  - **On** — source tallied on the MultiViewer based on the TSL input. TSL mnemonic source names are used.
  - **Tally Only** — source tallied on the MultiViewer based on the TSL input. TSL mnemonic source names are not used.

*Note: If a TSL ID is assigned to a source, the switcher overwrites the source name on the MultiViewer and mnemonics with the TSL name. If there is no TSL name, or it has not been received yet, the source name is blank. For the labels on the MultiViewer, a combination of the TSL name and switcher source name are used. The new TSL name is passed from the switcher to any downstream TSL devices.*

## Mnemonics

The mnemonic displays on the control panel show the name of the video source and can be customized for font size, color, and in some cases icons can be added. The customization that is available depends on the control panel you are using.

*Note: The SoftPanel uses the Carbonite settings.*

### To Customize Mnemonics for TouchDrive

The TouchDrive control panels support RGB color mnemonics and icons.

1. Click **Navigation Menu > Configuration > Inputs > External** if you are setting up a physical input, or **Internal** if you are setting up an internal input.
2. Click the **TouchDrive** button for the source you want to customize the mnemonics for.

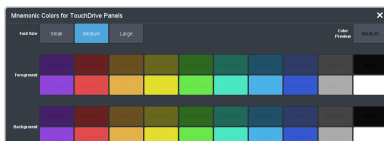

| Setting   | Description   |
|-----------|---|
| Font Size | Click <b>Small</b> , <b>Medium</b> , or <b>Large</b> to select the size of the font used on the mnemonic display. The larger the font, the fewer characters that are visible on the mnemonic. |

| Setting    | Description  |
|------------|--|
| Foreground | Click a <b>Foreground</b> button to select the color you want to apply to the text and icon on the mnemonic. |
| Background | Click a <b>Background</b> button to select the color you want to apply to the background on the mnemonic.    |

3. Click the **Icon** button for the source you want to customize the mnemonics for and click the icon you want to use.

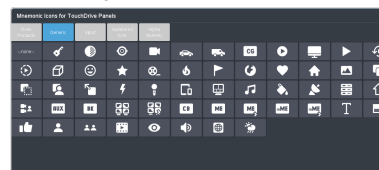

### To Customize Mnemonics for Carbonite Black

The Carbonite control panels support three-color mnemonics without icons.

1. Click **Navigation Menu > Configuration > Inputs > External** if you are setting up a physical input, or **Internal** if you are setting up an internal input.
2. Click the **Carbonite** button for the source you want to customize the mnemonics for.

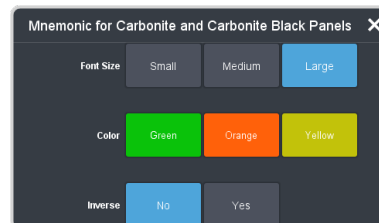

| Setting   | Description   |
|-----------|---|
| Font Size | Click <b>Small</b> , <b>Medium</b> , or <b>Large</b> to select the size of the font used on the mnemonic display. The larger the font, the fewer characters that are visible on the mnemonic. |
| Color     | Click a <b>Color</b> button to select the color you want to apply to the mnemonic. The color is applied either to the background or the font, depending on the <b>Inverse</b> setting.        |
| Inverse   | Click an <b>Inverse</b> button to have the color applied to the background ( <b>No</b> ) or the text ( <b>Yes</b> ).  |

## Auto Key Setup

An auto key allows you to associate a key alpha with a key video source in the switcher. When the video source is selected as a keyer, the key alpha is automatically used.

### To Set Up an Auto Key Association

As well as input sources, internally generated sources, such as media-stores and color backgrounds, can be set up as an auto key.

1. Click **Navigation Menu > Configuration > Inputs > External** if you are setting up a physical input, or **Internal** if you are setting up an internal input.
2. Click the **Alpha** button for the key video source that you want to assign an alpha to.



3. Click the **Alpha Source** button for the source that you want to assign to the key video.
  - **--none--** — no alpha
  - **White** — uses internally generated white for the alpha
  - **XX** — assign the source on the selected input as a key alpha
  - **BK** — assign internal black as a key alpha
  - **BG** — assign the matte generator as a key alpha
  - **MX** — assign the video on Media-Store X as a key alpha
  - **MEX** — assign the program output of ME X as the key alpha
  - **MEX PV** — assign the preview output of ME X as the key alpha
  - **MEX CLN** — assign the clean feed output of ME X as the key alpha
  - **PGM** — assign the main program output as the key alpha
  - **PRV** — assign the main preview output as the key alpha
  - **CLN** — assign the main clean feed output as the key alpha
  - **MiniMEX** — assign the output of MiniME™ X as the key alpha
4. Click an **Alpha Mode** button to select the alpha mode for the key alpha.

- **Linear** — switcher performs a multiplicative key. The key alpha cuts a hole based on the gradient values of the alpha. Shades of gray are translated into transparency levels, giving the key a soft edge. Unshaped key alphas can also be considered true linear alphas.
- **Shaped** — switcher perform an additive key. With shaped keys, the key alpha cuts a hole based on the monochrome value of the alpha. Shades of gray are translated into either white or black, giving the key a hard edge. Shaped Key alphas are sometimes used with Character Generators to cut very precise holes for the fill.

## GPI Device Control

You can assign a GPI output to a video source for basic external device control. When a video source is taken on-air, the switcher can be set to trigger a GPI output, with a pre-delay. The external device can be set up to cue a clip, or load a page when it receives the GPI input trigger.

### To Assign a GPI to a Video Source

Assign a GPI to a video source to trigger events on external devices.

1. Click **Navigation Menu > Configuration > Inputs > External** if you are setting up a physical input, or **Internal** if you are setting up an internal input.
2. Click the **GPO** button for the video source that you want to assign a GPI output to. If you are using the GPI to control the device, the video source should be the video output coming from the device.
3. Click the GPI output that you want to assign to the video source.

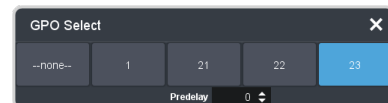

**Note:** You must have GPIs set as outputs to be able to assign them to the video source.

4. In the **Pre-delay** field, enter the pre-delay time, in frames, you want to use with the GPI output. When you transition a video source with a GPI assigned to it, and the Roll Clip feature



is active, the switcher triggers the GPI output, and then waits the pre-delay time before performing the transition. The length of the pre-delay is usually the length of time your video server requires to start playing a clip or your character generator requires to load a page.

## Tallies Setup

Tallies are simple contact closure relays that the switcher uses to signal other devices, and users, that a particular video source is on-air. Typically, tallies are used to light a red light on a camera to show people that they are on-air and what camera they should be looking at.

**Note:** Tallies are tied to the On-Air setting for the bus the source is selected on. If the bus is not set to be tallied as on-air, the tallies for the sources selected on that bus do not trigger. Refer to [On-Air Setting](#) on page 72 for information on setting the on-air status.

## To Assign a Tally to an Input

Tallies are assigned to inputs and are triggered when that input is selected on a bus that is on-air or is going on-air.



**Important:** A control panel is required to perform this procedure. If you do not have access to a physical control panel, the SoftPanel can be used. The position of items on the menus on the SoftPanel may not match those of a physical panel.

1. Press **MENU** > **Config** > **NEXT** > **Tally**.
2. Press **Add**.  
If you are editing, or deleting, an existing tally, use the **Add** knob to select the tally and press **Edit**, or **Delete**.
3. Use the **Tally** knob to select the tally or GPI output that you want to set up. This is the tally or GPI number, not the pin on the tally connector.  
**Note:** A GPI must be set to tally mode before it can be used as a tally. Refer to [To Set Up a GPI Output](#) on page 90 for information in setting a GPI as a tally.
4. Use the **Input** knob to select the video source that you want to tally.
5. Use the **Output** knob to select the bus that you want to video source tallied for. When the video source is selected on this bus, the tally is triggered.
6. Press **Tally** to save the settings.

## Custom Page Auto Follow

DashBoard pages can be assigned to custom page buttons in Live Assist. These custom pages can then be assigned to video inputs allowing Live Assist to auto follow to these pages when that video input is selected. For example, you can assign a custom page to the DashBoard page that controls a robotic camera. You can then set that custom page to follow the input from that camera. Whenever you select that camera as a source, Live Assist will jump to the custom page for that camera.

**Note:** PanelLink must be active in Live Assist for auto follow to function.

## To Assign a Page to a Custom Page Button

The custom page buttons on the Live Assist page can be assigned any custom page or node in DashBoard. This allows you to quickly access controls from another device on DashBoard from Live Assist on your current device.

1. Click **Navigation Menu** > **Configuration** > **System** > **Live Assist**.



2. Click on the **Address** drop-down list for the custom page button you want to assign to a page.
3. Select the connection or custom panel that you want to assign to the custom page button.
  - **All Connections** — expand the list and select the device and node that you want to assign to the custom page button. Some older DashBoard nodes from plug-ins may not display properly on the Live Assist buttons.

**Note:** Do not assign the Live Assist page to a custom page on the same machine.

- **Open Panels** — expand the list and select the open custom panel you want to assign to the list. You must have the custom panel running on DashBoard for it to appear in the list.

**Tip:** Click **Clear** to remove the custom page and name assigned to that button.

4. Click on the name field for the custom page button you are assigning a page to and enter a descriptive name for the custom page. The name appears on the button in Live Assist.

### To Assign a Custom Page to Follow an Input

Assign a Live Assist custom page to follow a physical or internal video source.

1. Click **Navigation Menu > Configuration > Inputs > External** if you are setting up a physical input, or **Internal** if you are setting up an internal input.
2. Click the **Panel Follow** button for the input you want to assign a custom page to.



3. Click the custom page you want to assign to the input or click **none**.

## Substitution Table

A substitution table allows you to specify a different source that will be taken on a bus when a specific source is selected on that bus. The substitution table requires either a MultiScreen or ME follow to be set up between the buses to trigger the substitution.

The substitution table can be used with the ME follows feature to create multilingual production feeds. For example, you can have ME 2 follow ME 1 to simultaneously produce multiple feeds. When a source is selected on ME 1, the same source is selected on ME 2. With the substitution table you can have it that when camera 1 is selected on ME 1 the follow will select camera 1 on ME 2 but the substitution table substitutes camera 4 for camera 1 on ME 2. Refer to [ME Follows](#) on page 71 for information on setting up ME follows.

When working with a MultiScreen setup, the substitution tables allow you to take pre-tiled sources from a CG or video server and have the switcher treat them as a single source across multiple areas or buses. When the first tile is selected on MiniME™ 1, the substitution table also selects the second tile on MiniME™ 2.

### Keep the following in mind:

Keep the following in mind when working with substitution tables:

- When working with a MultiScreen, the bezel compensation and data doubling setting should be set up on the source generator.
- If you want to create a substitution for an auto-select key, you must set up a substitution for both the fill and the alpha.
- Selecting a crosspoint directly on a bus that has a substitution set up for it overrides the substitution. The substitution continues when a new source is selected on the leading bus.

### To Set Up a Pre-Tiled Source

The substitution table is a single table that allows you to specify a different source that should be taken when a specific source is selected on a bus. The substitution table requires either a MultiScreen or ME follow to be set up between the buses to trigger the substitution.

*Tip: When you select the Source on the ME/Bus, the Substitution source is taken instead.*

1. Click **Navigation Menu > Configuration > Inputs > Substitutional**.



2. Click **New ME Sub** or **New Bus Sub** to select the type of substitution table you want to set up.
  - **New ME Sub** — create a substitution on a MiniME™.
  - **New Bus Sub** — create a substitution on a key bus of an ME or MiniME™, or an aux bus.
3. Click the **Source** button and select the source that you want to substitute with another source.
4. Click the **ME** or **Bus** button and select the area that you want the substitution to occur on.
5. Click the **Substitution** button and select source you want to substitute for the selected one. Repeat for any additional substitutions you want to create.
6. Click **Save**.



# Video Outputs

The BNC outputs can have any video source in the switcher, including Media-Store channels, aux bus, and clean feed assigned to them.

## Video Output Setup

You can assign a video source or bus to an output BNC. Some outputs can only be used for certain features

| Out BNC | MultiViewer (HD)  | MultiViewer (SD/3G) | MiniME™ Edge Blending | Down Converters           |
|---------|-------------------|---------------------|-----------------------|---------------------------|
| 1       | MV1 or any output | MV1 only*           | yes                   | Only 2 (no deinterlacing) |
| 2       | MV2 or any output | MV2 only*           | yes                   |                           |
| 3       | MV1 or any output | MV1 only*           | yes                   |                           |
| 4       | MV2 or any output | MV2 only*           | yes                   |                           |
| 5       | no                | no                  | yes                   |                           |
| 6       | no                | no                  | yes                   |                           |
| 7       | no                | no                  | yes                   |                           |
| 8       | no                | no                  | yes                   |                           |
| 9       | no                | no                  | yes                   |                           |
| 10      | no                | no                  | yes                   |                           |
| 11-22   | no                | no                  | no                    |                           |

**Note:** \* If the switcher is operating in a standard-definition or 3G video format, the MultiViewer outputs are only available on BNC 1 and 2, or 3 and 4. If one of the outputs in either of these pairs is set to a MultiViewer then the other output in the pair is also set to a MultiViewer.

### To Set up a Video Output

Assign video sources or buses to the output HD-BNC or HDMI™ ports. Some outputs are fixed to a specific video signal.

1. Click **Navigation Menu > Configuration > Outputs.**

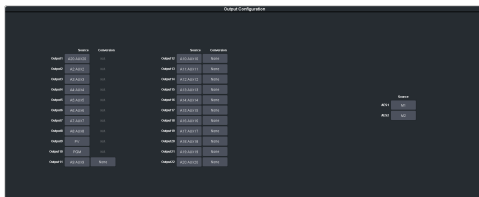

2. Click on the **Source** button for the output that you want to assign a source to.

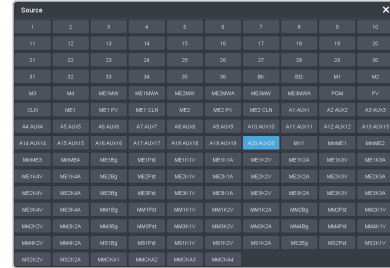

3. Click the video source that you want to assign to the output.
  - **Physical** — the physical inputs to the switcher.
    - **XX** — output XX
  - **Internal** — the internally generated sources of the switcher (ME, MiniME™, chroma key outputs, etc.).
    - **BK** — black
    - **BG** — matte generator
    - **MX** — Media-Store video channel X
    - **MXA** — Media-Store alpha channel X
    - **MEXMW** — Media-Store video channel used for MediaWipe effects on ME X (if installed)
    - **MEXMA** — Media-Store alpha channel used for MediaWipe effects on ME X (if installed)
    - **MinMEX** — main program output of MiniME™ X
    - **MMX PV** — main preview output of MiniME™ X
    - **MMXCmb** — combined alpha of MiniME™ X
    - **PGM** — main program output of the switcher
    - **PRV** — main preview output of the switcher
    - **CLN** — clean feed for main program of switcher
    - **MEX** — main program output of ME X (if installed)
    - **MEX PV** — main preview output of ME X (if installed)
    - **MEX CLN** — clean feed output of ME X (if installed)
    - **MMCKX** — MiniME™ chroma key X video
    - **MMCKXA** — MiniME™ chroma key X alpha
  - **Aux Follows** — the aux buses.

- **AUXXX** — output of aux bus XX
- **ME Follows** — the background, preset, and key buses of each ME.
  - **MEXBg** — source on background of ME X (if installed)
  - **MEXPst** — source on preset output of ME X (if installed)
  - **MEXKYV** — key Y video of ME X (if installed)
  - **MEXKYA** — key Y alpha of ME X (if installed)
- **MiniME Follows** — the background, preset, and key buses of each MiniME™.
  - **MMXBg** — source on background of MiniME™ X
  - **MMXPst** — source on preset output of MiniME™ X
  - **MMXKYV** — key Y video of MiniME™ X
  - **MMXKYA** — key Y alpha of MiniME™ X
- **MultiScreen Follows** — the background, preset, and key buses of each MultiScreen.
  - **MSXBg** — source on background of MultiScreen X
  - **MSXPst** — source on preset output of MultiScreen X
  - **MSXKYV** — key Y video of MultiScreen X
  - **MSXKYA** — key Y alpha of MultiScreen X

**Note:** The MiniME™ preset only shows the source that is selected on the preset bus for the MiniME™. This does not include keys or any video manipulation that is done if the MiniME™ is used as part of a MultiScreen.

## Ancillary Data

Ancillary data is information such as closed captioning or embedded audio that is included in the non-active video portions of the video signal. These portions include the Horizontal Ancillary Data Space (HANC) and Vertical Ancillary Data Space (VANC).

The switcher can be configured to strip or pass this data from the video output. The amount of data, and how it is stripped, depends on the video format of the video signal.

**Note:** FSFCs strip embedded audio data from the video signal.

The following restrictions apply to ancillary data being included in the output:

- All ME program buses pass ancillary data.
- MultiViewer outputs do not include any ancillary data.
- MiniME™ and MultiScreen outputs do not include any ancillary data unless an ME with ancillary data is re-entered onto the background bus.
- ME Preview does not include ancillary data unless the background is not selected as part of the next transition.
- A MiniME™ or MultiScreen can include ancillary data if an ME is re-entered onto the background.
- Any format conversion on the input video signal.
- Setting ancillary data to be stripped.

**Table 2: Last Line of Vertical Ancillary Data**

| Video Format | Normal Strip/Pass | Long Strip/Pass |
|--------------|-------------------|-----------------|
| 480i         | 19                | 21              |
| 576i         | 22                | 24              |
| 720p         | 25                | 25              |
| 1080i        | 20                | 20              |
| 1080p        | 41                | 41              |

## To Strip or Pass Ancillary Data

Strip or pass ancillary data on video outputs. Video manipulation such as FSFC conversion automatically strips ancillary data from the video signal.

1. Click **Navigation Menu > Configuration > System > Global**.



2. Click an **Ancillary Mode** button to select whether ancillary data is stripped or passed.
  - **N Strip** — ancillary data is stripped
  - **N Pass** — ancillary data is passed unmodified
  - **L Strip** — ancillary data and some lines of active video are replaced with black

- **L Pass** — ancillary data and some lines of active video are passed unmodified

## FlexiClean Clean Feed

FlexiClean clean feed provides a second program output per ME that is derived from a different point in the video layering than the standard program output. The clean feed can be set to come before any key in the video layering for an ME. This allows you to remove particular keys without affecting the primary program output.

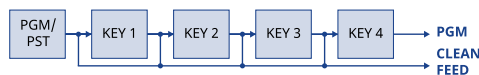

### Keep the following in mind:

Keep the following in mind when working with clean feeds:

- Recalling a memory register using MemoryAI may cause the clean feed output to look different than expected. MemoryAI allows key elements to be recalled to other keys than originally resulting in different key layering.

## To Set Up Clean Feed

Clean Feed can be taken before any or all of the keyers on an ME. This allows you to have a secondary output of an ME without any branding for re-broadcast or archival.

1. Click **Navigation Menu > Configuration > System > ME**.

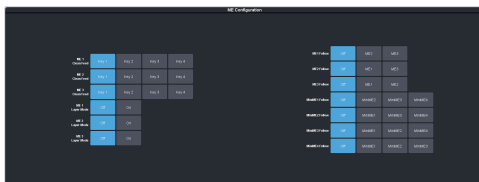

2. Click an **ME X Clean Feed** button to select which key the clean feed for that ME is taken before.

The selected key, and all keys after it, are not included in the clean feed output.

## External Layer Mode

The clean feed for an ME is used to create a composite alpha from the keyers on that ME that is then available as a single alpha source. This allows you to output both the video and alpha from an ME to an external switcher. The key video comes from the output of the ME and

the key alpha comes from the clean feed of the ME.

The alphas that are included in the layer mode output are set with the keyer buttons in the next transition area. Toggle a keyer button on to include the alpha from that keyer in the layer mode output.

When layer mode is turned on for an ME, you are restricted to cut, dissolve, and wipe transitions. MediaWipe and DVE transitions are not available.

*Tip: To use layer mode internally, select the clean feed for the ME that is set to layer mode as the alpha for an auto key on another ME or a MiniME™.*

## To Set Up Layer Mode

Use the clean feed to output a composite alpha of the keys on that bus.

1. Click **Navigation Menu > Configuration > System > ME**.

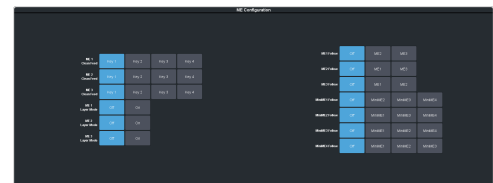

2. Click an **ME X Layer Mode** button to turn layer mode on (**On**), or (**Off**) for that ME.

## ME Follows

An ME or MiniME™ can be linked to another ME or MiniME™ so that actions performed on the first are duplicated on the following. Linking can only be set between areas of the same type. You cannot have a MiniME™ follow an ME.

*Tip: The ME follows can also be used with the substitution table feature to create multilingual production feeds. For example, you can have ME 2 follow ME 1 to simultaneously produce multiple feeds. When a source is selected on ME 1, the same source is selected on ME 2. With the substitution table you can have it that when camera 1 is selected on ME 1 the follow will select camera 1 on ME 2 but the substitution table substitutes camera 4 for camera 1 on ME 2.*

### Keep the following in mind:

Keep the following in mind when working with ME Follows:

- You cannot have a MiniME™ follow an ME.
- There must be available resources for the following ME or MiniME™.
- Memories and resets are also performed on the following ME or MiniME™.

- Chroma Key initialization is only performed on the leading ME or MiniME™. The following ME or MiniME™ get the same chroma key parameters as the leading ME or MiniME™. If you are substituting the source on the following ME or MiniME™ the chroma key will not be initialized properly for that source.
- You must turn the MultiScreen off to be able to set the follows for the MiniME™.
- You cannot cascade/re-enter follows. For example, if MiniME™ 1 is following MiniME™ 2, MiniME™ 2 cannot be set to following anything and no other MiniME™ can follow MiniME™ 1.

## To Set Up an ME Follow

Set an ME or MiniME™ to follow another ME or MiniME™. Actions on the first ME or MiniME™ are duplicated on the following ME or MiniME™.

1. Click **Navigation Menu > Configuration > System > ME.**

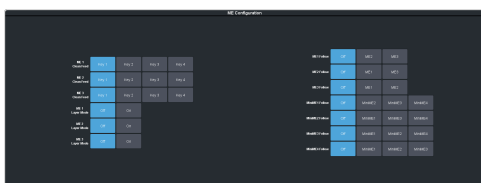

2. Click the **ME XFollow** or **MiniME XFollow** button for the ME that you want ME or MiniME™ X to follow.

For example, click **ME 2** in the **ME 1 Follow** row to have actions performed on ME 2 duplicated on ME 1.

**Note:** The MiniME™ follows are only available if the MiniME™ is not being used for a MultiScreen. You must turn the MultiScreen off to be able to set the follows for the MiniME™.

**Tip:** Select **Off** to have the ME or MiniME™ not follow anything.

## On-Air Setting

Some switcher outputs can be set to be considered on-air or not. This allows you to set which outputs are tallied, how resource allocation is divided, and how the Roll Clip feature works.

### To Set the On-Air Status for an Output

Set an output to be on-air to tally sources that are selected on that bus.

1. Click **Navigation Menu > Configuration > On Air.**

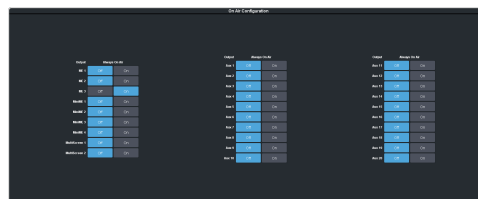

2. Click an **Always OnAir** button for an output to select whether the output is considered on-air (**On**) or not (**Off**).

**Tip:** Setting an output to be always on-air tallies sources that are selected on that bus, or are going to be taken on-air with the next transition.

# MultiViewer

The MultiViewer allows you to view multiple video sources from a single output BNC. Video inputs or outputs on the switcher, including Program, Preview, and Media-Store channels, can be assigned to any box on the MultiViewer. Up to 2 (5 on Carbonite Black+) MultiViewer outputs are supported.

A time-clock can be added as an overlay to the MultiViewer showing either system time or time code.

### Keep the following in mind:

Keep the following in mind when working with a MultiViewer:

- MultiViewer outputs are assigned to output BNCs 1/2 or 3/4.
- On Carbonite Black+ the additional MultiViewer outputs are fixed to output BNCs MV 3, 4, and 5.
- The layout is configured independently for each MultiViewer.
- Inputs are displayed with a red border when they are on-air. A green border is displayed when the input is selected on the Preset bus.
- When the switcher is operating in a standard-definition video format, the MultiViewer is shown in high-definition.
- If the switcher is operating in a standard-definition or 3G video format, the MultiViewer outputs are only available on BNC 1 and 2, or 3 and 4. If one of the outputs in either of these pairs is set to a MultiViewer then the other output in the pair is also set to a MultiViewer.
- All ancillary data is stripped from the MultiViewer outputs.

## MultiViewer Output Formats

Depending on the format the switcher is operating in, the MultiViewer may output a different video format than the switcher is operating in.

| Switcher Video Format | MultiViewer Format |
|-----------------------|--------------------|
| 480i                  | 1080i 59.94Hz      |
| 576i                  | 1080i 50Hz         |
| 720p 50Hz             | 720p 50Hz          |
| 720p 59.94Hz          | 720p 59.94Hz       |

| Switcher Video Format | MultiViewer Format |
|-----------------------|--------------------|
| 1080i 50Hz            | 1080i 50Hz         |
| 1080i 59.94Hz         | 1080i 59.94Hz      |
| 1080pSF 23.98Hz       | 1080pSF 23.98Hz    |
| 1080pSF 25Hz          | 1080i 50Hz         |
| 1080pSF 29.97Hz       | 1080i 59.94Hz      |
| 1080p 25Hz            | 1080p 25Hz         |
| 1080p 29.97Hz         | 1080p 29.97Hz      |
| 1080p 50Hz            | 1080i 50Hz         |
| 1080p 59.94Hz         | 1080i 59.94Hz      |

## To Set Up a MultiViewer

**Note:** A MultiViewer must be assigned to a video output to be usable.

1. Click **Navigation Menu > Configuration > MultiViewers** and click the **MultiViewer X** button for the MultiViewer you want to set up.

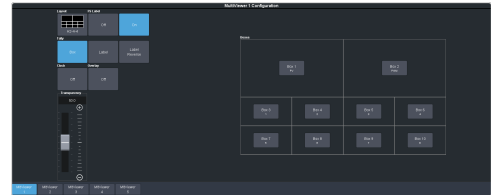

**Note:** If the switcher is operating in a standard-definition or 3G video format, click **Outputs** and select whether outputs 1 and 2 or outputs 3 and 4 are assigned to normal outputs (**Outputs**), or MultiViewer outputs (**MV 1-2**).

2. Click the **Layout** button and select the arrangement of the boxes that you want to use for the selected MultiViewer.

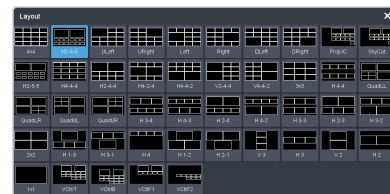

3. Use the **Transparency** slider to adjust the transparency of the background behind the source label for the selected MultiViewer.
4. Apply an overlay to the MultiViewer as follows:
  - a) Click the **Overlay** button and click **On** to turn the overlay on, or **Off** to turn it off.

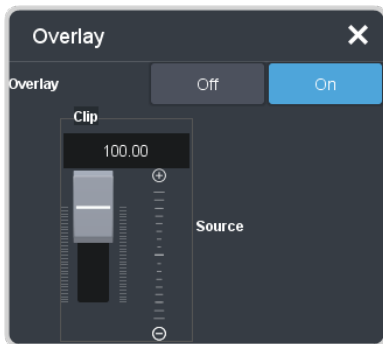

**Note:** The overlay feature is only available when a layout of less than 16 boxes is used.

**Tip:** The overlay is primarily used for MultiViewer, but can also be used to overlay a camera shot of a shot-clock over the MultiViewer output.

- b) Click the **Source** button for the video source that you want to overlay over the MultiViewer output.
- c) Use the **Clip** slider to adjust the clipping of the overlay source.

At **0%** the overlay source is completely opaque, and at **100%** it is completely transparent.

5. Click a **Tally** button to select how boxes on the MultiViewer are tallied.
  - **Box** — red or green border is shown around the outside of the MultiViewer box
  - **Label** — red or green boxes are shown inside the label area of the MultiViewer box
  - **Label Reverse** — the same as Label, but the placement of the tally boxes is swapped
6. Click an **FS Label** button to select whether FSFC is shown on the source labels (**On**) or not (**Off**) when a FSFC is applied to the source.
7. Click on one of the **Boxes** buttons and select the source that you want to assign to that box on the MultiViewer.



- **Physical** — the physical inputs to the switcher.

- **Internal** — the internally generated sources of the switcher (ME, MiniME™, chroma key outputs, etc.).
- **Aux Follows** — the aux buses.
- **ME Follows** — the background, preset, and key buses of each ME.
- **MiniME Follows** — the background, preset, and key buses of each MiniME™.
- **MultiScreen Follows** — the background, preset, and key buses of each MultiScreen.

8. Set up how that box appears on the MultiViewer.

| Setting            | Description  |
|--------------------|--|
| <b>Green Tally</b> | Turn the preview (green) tally for the MultiViewer box <b>Off</b> or <b>On</b> .   |
| <b>Red Tally</b>   | Turn the program (red) tally for the MultiViewer box <b>Off</b> or <b>On</b> .   |
| <b>Border</b>      | Turn the border around the MultiViewer box off ( <b>Off</b> ), white ( <b>White</b> ), or black ( <b>Black</b> ). When the border is turned off, some distortion may be visible around the edges of the box. |
| <b>Label</b>       | Turn source labels for the MultiViewer box <b>Off</b> , or <b>On</b> .   |
| <b>Label Pos</b>   | Select whether the source label for the MultiViewer box appears below ( <b>Bottom</b> ) or above ( <b>Top</b> ) the image.   |
| <b>Display</b>     | Select whether the source name on the label shows the internal mnemonic name ( <b>Mnemonic</b> ), the TSL UMD name ( <b>TSL</b> ), or both names ( <b>Both</b> ).  |
| <b>Aspect</b>      | Turn aspect ratio markers for the MultiViewer box <b>Off</b> or <b>On</b> .  |
| <b>MultiSc X</b>   | Turn the MultiScreen overlay <b>Off</b> or <b>On</b> . The overlay shows what portions of the image are cropped to fit into the output of the MultiScreen.   |

**Tip:** If you select a source on an aux bus that does not have a TSL UMD name, the mnemonic name is used instead on the MultiViewer.

## To Set Up a MultiViewer Clock

The clock can show the current system time or LTC data being sent to the switcher.

1. Click **Navigation Menu > Configuration > MultiViewers** and select the MultiViewer that you want to apply the clock overlay to.
2. Click the **Clock** button.



3. Click a **Mode** button to select the type of clock you want.
  - **Off** — turns the clock off
  - **Timecode** — displays the timecode fed to the switcher (hh:mm:ss:ff)
  - **System** — displays the system time of the switcher in 12-hour or 24-hour format (hh:mm:ss)
4. For a **Timecode** clock, click a **Frame Count** button to select whether the number of frames for a timecode is displayed (**On**) or not (**Off**).

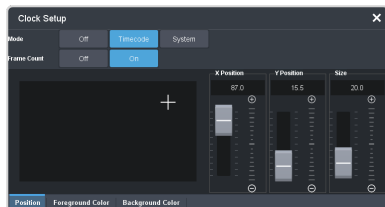

5. For a **System** clock, click a **Time Display** button to set how the time is displayed.

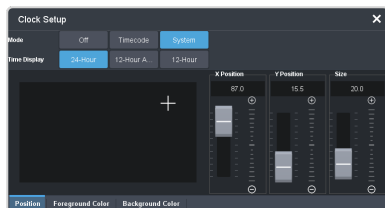

- **24 hr** — time is displayed in 24-hour format.
  - **12 hr** — time is displayed in 12-hour format without am/pm.
  - **12 hr AM/PM** — time is displayed in 12-hour format with am/pm.
6. Click the **Position** tab.
  7. Use the **X Position**, **Y Position**, and **Size** sliders to position the clock and change the size.
  8. Click the **Foreground Color** tab and select the color and transparency you want to use for the text of the clock.

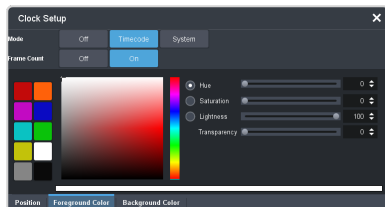

9. Click the **Background Color** tab and select the color and transparency you want to use for the background of the clock.



# MultiScreen / MiniME™

The MultiScreen allows you to output multiple video signals that can be combined into a single scene. The switcher treats the multiple outputs as a single background and translates the keys across the multiple backgrounds.

*Tip:* For information on pre-tiled sources, refer to [Substitution Table](#) on page 68.

## Keep the following in mind:

Keep the following in mind when setting up a MultiScreen environment.

- The MultiScreen uses MiniME™ resources to provide the outputs. This allows you to have up to two DVE keys per screen of the MultiScreen. As a key crosses from one screen to the next, a key from either of the MiniME™ outputs is being used to provide the two halves of the key.
- MultiScreen does not support chroma keys.
- The MultiScreen can either take separate parts of a pre-tiled source, or scale a single source to the size of the MultiScreen output. When you use a pre-tiled source, you must assign sources to each MiniME™ that is used in the MultiScreen. This substitution table allows you to select a single source on the MultiScreen program bus and the switcher automatically assigns the required source to each MiniME™.

## MiniME™ Assignment

Each MiniME™ output is pre-assigned to a screen on the MultiScreen layout. MiniME™ 1 and 2 are assigned to MultiScreen 1 and MiniME™ 3 and 4 are assigned to MultiScreen 2. If you select a layout that uses more than two screens, the MiniME™ resources that were assigned to MultiScreen 2 are assigned to MultiScreen 1.

## To Set Up a MultiScreen

1. Click **Navigation Menu > Configuration > Canvases**.

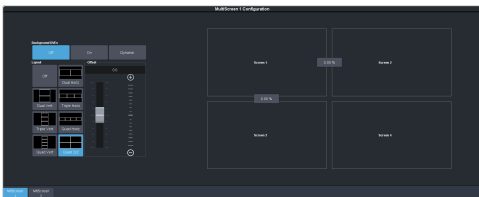

2. Click **MultiScreen X** to select the MultiScreen you want to set up.
3. Click a **Layout** button to select the layout you want to use.

*Note:* The available layouts depend on the number of screens being used by the other MultiScreen.

4. Click **Yes** to confirm.
5. Click a **Background DVEs** button to select how DVE resources are used to scale sources for the MultiScreen screens.
  - **Off** — DVE resources are not allocated to the MultiScreen for scaling of background sources.
  - **On** — DVE resources are always allocated to the MultiScreen for scaling of background sources. This reduces the number of available DVE resources to the switcher when a MultiScreen is turned on.
  - **Dynamic** — DVE resources are dynamically allocated to the MultiScreen for scaling of background sources if there is no substitution table.

*Note:* If there are no DVE resources to scale the background source across the entire MultiScreen, the switcher needs a substitution table to map separate inputs to the MultiScreen screens or the selected source is repeated in each screen of the MultiScreen.

6. Click **OK**.
7. Use the **Offset** slider to adjust the placement of the background scaling in the MultiScreen output.

This can be used to adjust for the aspect ratio difference between the input video and the MultiScreen output.

8. Click on the button between the two boxes to adjust the size of the edge between those two screens.

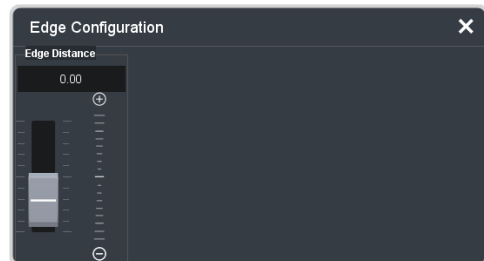

9. Use the **Edge Distance** slider to adjust the size of the gap between the MultiScreen screens.

- If you are using monitors for your MultiScreen display, you can use a positive value to compensate for the bezel on the outside of a display.
- If you are using projectors for your MultiScreen display, you can use the negative value to compensate for the amount of overlap of the projected images.

10. If you selected a negative distance, click an **Edge Blending** button to turn edge blending on (**On**) or off (**Off**).

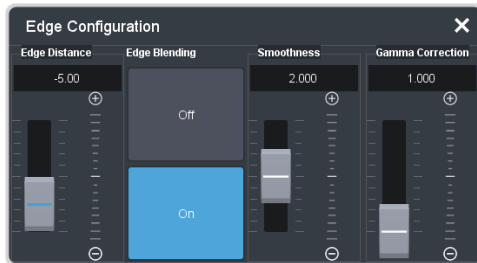

11. If the edge blending is on, use the **Smoothness** and **Gamma Correction** sliders to correct for the overlap in projected images.
  - **Smoothness** — adjust the appearance of the transition area between the overlapping images.
  - **Gamma Correction** — adjust the gamma correction applied to the overlapping images to match the output of your projectors.
12. Repeat the edge adjustment for all other edges in your layout.

# Frame Sync and Format Conversion

The switcher has multiple input frame synchronizer / format converter (FSFC) and input de-interlacers that can be used to convert video input signals to the format that the switcher is operating in, as well as correct mistimed, or drifting, video input signal. The frame synchronizers cannot completely correct badly formatted video, mistimed switches, signal drops, or similar issues.

Carbonite Black+ has 11 additional output format converters that can be used to convert the output video signal from the video format that the switcher is operating in to another format required by a downstream device.

Each FSFC channel maintains a separate setting for different video formats. This lets you change between video formats without losing FSFC channel configurations.

## Keep the following in mind:

Keep the following in mind when working with Frame Synchronizers and Format Converters:

- If a video format not compatible with the currently defined conversion is used, the video image is frozen with the last successfully processed image frame.
- FSFCs create a one-frame delay in the video output of the switcher for the video signal being converted.
- FSFCs strip embedded audio data from the video signal. Ensure that no FSFC channels are assigned to any input or bus you are using with external audio mode.
- In the standard mode on Carbonite Black, the FSFCs are fixed to the first 6 input BNCs.
- The output format converters in the Carbonite Black+ frame are only available on output BNCs 11 to 22.
- In the Standard switcher mode, the switcher cannot frame sync a 1080pSF video format on input BNC 1. All other inputs work correctly.
- The FSFCs used in the switcher conform to the SMPTE ST 125:2013 standard. Some older equipment may not fully conform to the current standards and can send out-of-spec video to the switcher which can have unexpected results. Ensure that video coming

into the switcher conforms to current standards, especially with regard to 480i video signals with variable blanking sizes.

## Supported FSFC Video Formats

FSFCs can only convert between specific video formats at a given frequency. The available conversions also depends on the switcher mode you are in.

- The switcher supports synchronized and unsynchronized 1080p and 1080i inputs. The 1080i inputs are converted using a 4-line interpolator and may result in lower quality video.
- In the standard mode on Carbonite Black, the FSFCs are fixed to the first 6 input BNCs.

**Table 3: Supported FSFC Input and Output Formats**

| Input           | Switcher      | Output        |
|-----------------|---------------|---------------|
| 1080p 59.94Hz   | 1080p 59.94Hz | 1080p 59.94Hz |
| 1080i 59.94Hz   |               | 1080i 59.94Hz |
| 720p 59.94Hz    |               | 720p 59.94Hz  |
|                 |               | 480i          |
| 1080p 50Hz      | 1080p 50Hz    | 1080p 50Hz    |
| 1080i 50Hz*     |               | 1080i 50Hz    |
| 720p 59.94Hz    |               | 720p 59.94Hz  |
|                 |               | 576i          |
| 1080p 29.97Hz   | 1080p 29.97Hz | 1080p 29.97Hz |
| 1080p 59.94Hz** |               |               |
| 1080p 25Hz      | 1080p 25Hz    | 1080p 25Hz    |
| 1080p 50Hz**    |               |               |
| 1080i 59.94Hz   | 1080i 59.94Hz | 1080i 59.94Hz |
| 1080p 59.94Hz   |               | 1080p 59.94Hz |
| 720p 59.94Hz    |               |               |
| 480i            |               | 480i          |
| 1080i 50Hz      | 1080i 50Hz    | 1080i 50Hz    |
| 1080p 50Hz      |               | 1080p 50Hz    |
| 720p 50Hz       |               |               |
| 576i            |               | 576i 50Hz     |
| 720p 59.94Hz    | 720p 59.94Hz  | 720p 59.94Hz  |
| 1080p 59.94Hz   |               | 1080p 59.94Hz |
|                 |               | 1080i 59.94Hz |
|                 |               | 480i          |

| Input         | Switcher     | Output        |
|---------------|--------------|---------------|
| 720p 50Hz     | 720p 50Hz    | 720p 50Hz     |
| 1080p 50Hz    |              | 1080p 50Hz    |
|               |              | 1080i 50Hz    |
|               |              | 576i          |
| 576i          | 576i 50Hz    | 576i          |
| 1080p 50Hz    |              |               |
| 1080i 50Hz    |              | 1080i 50Hz    |
| 720p 50Hz     |              |               |
| 480i          | 480i 59.94Hz | 480i          |
| 1080p 59.94Hz |              |               |
| 1080i 59.94Hz |              | 1080i 59.94Hz |
| 720p 59.94Hz  |              |               |

locked together for timing so that all four inputs are in sync.

### Notes

- \* Converted using either a simple line-doubler or 4-line interpolater and may result in lower quality video.
- \*\* Converted by dropping frames and may result in lower quality video.

## To Set Up an Input FSFC

The conversion that is available depends on the format the switcher is operating in and the input that is being converted.

1. Click **Navigation Menu > Configuration > Inputs > External**.
2. Click the **Configure** button for the input you want to assign an FSFC to.

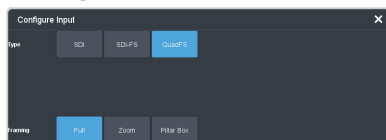

3. Click a **Type** button to turn on the FSFC.
  - **SDI** — no FSFC is applied to the input.
  - **SDI-FS** — an FSFC is applied to the input.
  - **QuadFS** — a timed FSFC is applied to the input. Each QuadFS is timed to the first SDI-FS in the group of four (1-4, 5-8, 9-12). The SDI-FS must be applied to the first input and QuadFS to the rest of the inputs in the group.

**Tip:** Use this if you are taking the quad-split output from an untimed UHD camera that you need to frame-sync. The frame syncs applied to each input are

4. If required, select the aspect ratio conversion mode you want to use.

The options that are available depend on the video format that the switcher is converting from and to.

- **Full** — The video signal is scaled disproportionately to fill the display of the new aspect ratio. Aspect distortion occurs as the image is stretched/compressed to fit in the new aspect ratio.
- **Zoom** — The central portion of the video signal is zoomed to fill the display of the new video format. No aspect distortion is introduced but the edges of the video signal may be cropped.
- **Letter Box** — Black bars are added to the top and bottom of a 16:9 image to display correctly in a 4:3 video format.
- **Pillar Box** — Black bars are added to the right and left of a 4:3 image to display correctly in a 16:9 video format.

## Aspect Ratio Conversion

Converting between standard-definition and high-definition video formats often requires converting between 4:3 and 16:9 aspect ratios. The switcher support Full, Zoom, Letterbox, and Pillarbox conversions.

In 480i and 576i video formats you can use either a 4:3 or 16:9 aspect ratio.

### Full

The video signal is scaled disproportionately to fill the display of the new aspect ratio. Aspect distortion occurs as the image is stretched/compressed to fit in the new aspect ratio.

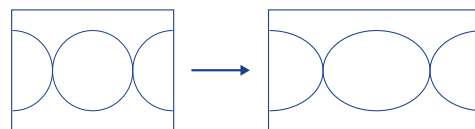

Figure 7: 4:3 to 16:9 Full Aspect Ratio Conversion

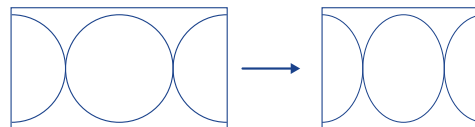
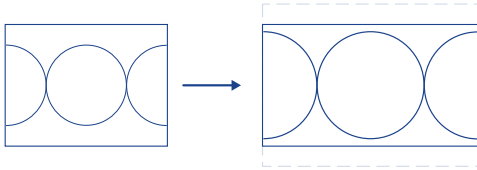

Figure 8: 16:9 to 4:3 Full Aspect Ratio Conversion

## Zoom

The central portion of the video signal is zoomed to fill the display of the new video format. No aspect distortion is introduced but the edges of the video signal may be cropped.



**Figure 9: 4:3 to 16:9 Zoom Aspect Ratio Conversion**

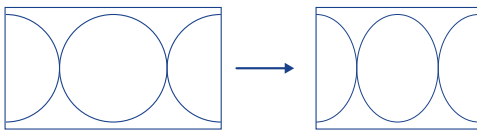

**Figure 10: 16:9 to 4:3 Full Aspect Ratio Conversion**

## Letterbox

Black bars are added to the top and bottom of a 16:9 image to display correctly in a 4:3 video format.

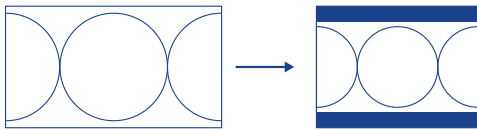

**Figure 11: 16:9 to 4:3 Letterbox Aspect Ratio Conversion**

## Pillarbox

Black bars are added to the right and left of a 4:3 image to display correctly in a 16:9 video format.

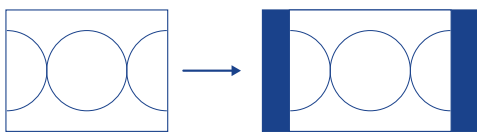

**Figure 12: 4:3 to 16:9 Pillarbox Aspect Ratio Conversion**

## To Set an Aspect Ratio for 480i/576i

You can only select an aspect ratio if the switcher is operating in 480i or 576i.

1. Press **MENU > Config > Input > NEXT**.
2. Use the **Input** knob to select the input that you want to set the aspect ratio for.
3. Use the **SD ASP** knob to select the aspect ratio (**16:9** or **4:3**) that you want to use.
4. Press the **Input** knob.
5. Press the **Confirm** knob to assign the aspect ratio.

---

# System Real-Time Clock/Date

The switcher uses an internal clock to generate the time for the clock overlay for the MultiViewer.

## To Set the System Real-Time Time and Date

1. Click **Navigation Menu > Configuration > System > Global**.
2. Click **Date and Time**.

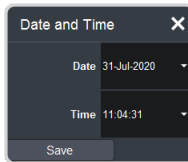

3. Click on the **Date** field and select the current date.
4. Click on the **Time** field and select the current time.
5. Click **Save**.

---

## AES Audio Output

Audio sources from the audio mixer, clip player, and Media-Store can be sent out the AES outputs of the frame.

Only Media-Store channels 1 and 2, and the MediaWipe channels can be assigned to an AES output. Embedded audio is not available on the AES outputs.

### To Assign Audio to an AES Output

Assign an audio source to one of the AES outputs on the frame.

1. Click **Navigation Menu > Configuration > Outputs**.
2. Click the **Source** button for the **AES X** output you want to assign an audio source to and select the Media-Store or MediaWipe you want to assign to it.

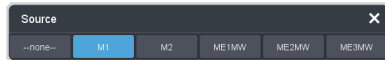

**Note:** Not all options are available, depending on the video format the switcher is operating in.

- **--none--** — no audio source is assigned to the AES output.
- **MX** — the audio from Media-Store X is assigned to the AES output.
- **ME<sub>X</sub>MW** — the audio from the MediaWipe on ME X is assigned to the AES output.



# Color Correction (Carbonite Black+ Only)

Color correction in the switcher is performed by either Processing Amplifiers (Proc Amps) in the HSL (Y-Cr-Cb) color space or by RGB Color Correctors in the RGB color space.

Both Proc Amps and RGB Color Correctors allow you to apply color correction to video on input to the switcher, before the crosspoint, and on the output from the switcher. Correction applied to the input video is then available to all MEs.

### Keep the following in mind:

Keep the following in mind when working with proc amps and color correctors:

- Color correction is additive, allowing you to apply any combination of Proc Amp and RGB Color Corrector based adjustment to a video signal. If multiple color corrections are applied, the correction is applied first, and the bus-based correction is applied after that.
- Output based correction is only available on output BNCs 11 to 22.

## Proc Amp Color Correction

The Proc Amp video correction allows you to adjust the gain, offset, black level, and gamma of the video signal.

### To Apply a Proc Amp to a Video Source

A Processing Amplifier (Proc Amp) applies color correction in the HSL (Y-Cr-Cb) color space for switcher sources.

**Note:** Only outputs 11 to 22 support output color correction.

1. Click **Navigation Menu > Configuration > ProcAmps > ProcAmp**.
2. Click the **ProcAmps and Color Correctors** button and select the video input or output that you want to apply the Proc Amp to.

**Tip:** If correction has already been applied (ON), press **Reset** to return the Proc Amp and Color Correctors to the default values.

3. Click an **Enable** button to turn the Proc Amp on (ON) for the selected video input or output.

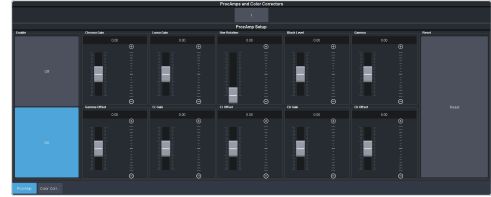

4. Use the sliders to adjust the video source.
  - **Chroma Gain** — adjust the chrominance gain only.
  - **Luma Gain** — adjust the luminance gain only.
  - **Hue Rotation** — adjust the Hue. Increasing the Hue Rotation turns the color wheel clockwise, and decreasing the Hue Rotation turns the color wheel counter-clockwise.
  - **Black Level** — adjust the black level. Black level acts as a luminance offset.
  - **Gamma** — adjust the luminance gamma value.
  - **Gamma Offset** — adjust the luminance gamma offset.
  - **Cr Gain** — adjust the gain of the Cr (red color difference).
  - **Cr Offset** — adjust the offset of the Cr.
  - **Cb Gain** — adjust the gain of the Cb (blue color difference).
  - **Cb Offset** — adjust the offset of the Cb.

## RGB Color Correction

The RGB color correctors allow you to adjust the red, green, and blue component gain, offset, and gamma of the video signal.

### To Apply a RGB Color Correction to a Video Source

An RGB Color Corrector applies color correction in the RGB color space for switcher sources.

**Note:** Only outputs 11 to 22 support output color correction.

1. Click **Navigation Menu > Configuration > ProcAmps > Color Correction**.
2. Click the **ProcAmps and Color Correctors** button and select the input or output that you want to apply the RGB color corrector to.

**Tip:** If correction has already been applied (ON), click **Reset** to return the Proc Amp and Color Correction to the default values.

3. Click an **Enable** button to turn the color corrector on (**On**) for the selected video input or output.

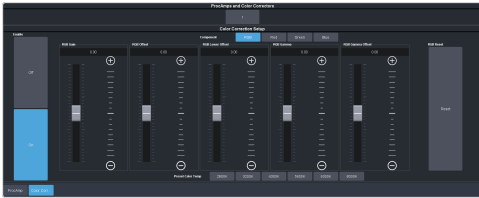

4. Click the **Component** button for the individual color component (**Red, Green, Blue**) you want to adjust, or **RGB** for all of them.
5. Use the sliders to adjust the color components.

*Tip: Click a **Preset Color Temperature** button to apply a temperature color correction to the video.*

- **Gain** — adjust the gain of the component(s).
- **Offset** — adjust the offset of the component(s).
- **Lower Offset** — adjust the lower offset of the component(s).
- **Gamma** — adjust the gamma value of the component(s).
- **Gamma Offset** — adjust the gamma offset of the component(s).

# Personality

Personality settings allow you to configure how you interact with the control panel and switcher, as well as how the buttons on the control panel appear. All of these settings are stored in the Personality register.

## Personality Settings

There are a number of settings for how the switcher will react to different situations, or how switcher elements appear to the operator. All these settings are grouped together into the Switcher Personality. These settings include double-press rates and sleep time, among others.

### General Settings

- Click **Navigation Menu > Personality > General**, or **Transition** for the transition settings.



| Personality              | Description   |
|--------------------------|---|
| <b>Editor Port</b>       | Allow the switcher to be controlled by an external editor. The external editor can control the switcher to perform transitions, or recall memories, among the supported commands. This setting is for the frame. <ul style="list-style-type: none"> <li><b>On</b> — allow the switcher to be controlled by an external editor.</li> <li><b>Off</b> — switcher ignores editor commands.</li> </ul> |
| <b>Button Brightness</b> | Set the overall brightness (0-100%) of all the buttons on any physical control panel connected to the switcher. This setting is unique to the control panel.  |
| <b>Rate</b>              | Have the switcher use frames or seconds for transition rates. Rates are entered and displayed in the select selected values. This setting is unique to the control panel. <ul style="list-style-type: none"> <li><b>Frames</b> — transition rates are in frames.</li> <li><b>Seconds</b> — transition rates are in seconds.</li> </ul>  |

| Personality          | Description   |
|----------------------|---|
| <b>Sleep Mode</b>    | have the switcher go into a sleep mode after a user-defined amount of time ( <b>Sleep Minutes</b> ) without user interaction. Touching any button, knob, or fader will wake the switcher. The switcher does not act on the button, knob, or fader control that wakes it from sleep mode. During sleep mode, video related hardware is not affected and video signals still pass through the switcher. This setting is unique to the control panel. <ul style="list-style-type: none"> <li><b>Power Save</b> — all buttons and displays are turned off and as much power is conserved as possible.</li> <li><b>Sleep</b> — displays are turned off and buttons light in raindrop pattern.</li> </ul> |
| <b>Sleep Minutes</b> | The amount of time that the switcher waits without user input before going into sleep mode. Setting the value to 0 (Off) prevents the switcher from entering sleep mode. This setting is unique to the control panel.   |
| <b>Toggle Shift</b>  | Have the <b>Shift</b> button either be latching (toggle) or momentary (off). When in toggle mode, you can press the shift button and then select a source on the shifted bus without having to hold down the shift button. This only affects the bus the shift button is on. This setting is unique to the control panel. <ul style="list-style-type: none"> <li><b>Off</b> — the <b>Shift</b> button only stays on as long as you are holding it down.</li> <li><b>Toggle</b> — when you press the <b>Shift</b> button it stays on until you press a source button on that bus.</li> </ul>   |
| <b>Memory Bank</b>   | Allows you to set how the <b>BANK</b> button behaves when pressed and released. This setting is unique to the control panel. <ul style="list-style-type: none"> <li><b>Normal</b> — the keypad is used to enter the bank number directly, followed by the memory (For example, to access memory 3 on bank 2, press <b>BANK &gt; 2 &gt; 3</b>.)</li> <li><b>Legacy</b> — the next bank is selected every time the button is pressed, cycling through all banks (For example, to access bank 5, press <b>BANK</b> repeatedly until bank 5 is selected.)</li> </ul>  |
| <b>Memory Undo</b>   | A memory recall can be reversed by pressing the memory number a second time after a memory is recalled. This is the same as pressing the <b>UNDO</b> button, if present on your control panel. This setting is unique to the control panel. <ul style="list-style-type: none"> <li><b>Off</b> — pressing the memory number again does not undo the recall.</li> <li><b>On</b> — pressing the memory number again undoes the last memory recall.</li> </ul>  |

## Transition Settings

- Click **Navigation Menu > Personality > Transition**.

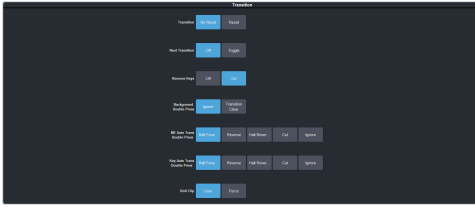

| Personality                    | Description   |
|--------------------------------|---|
| <b>Transition</b>              | <p>Have the next transition reset to a default background dissolve after each transition. This allows you to prevent the selections from the last transition from being accidentally included with the next transition. This setting is for the frame.</p> <ul style="list-style-type: none"> <li><b>No Reset</b> — the next transition settings are not changed after a transition.</li> <li><b>Reset</b> — the next transition is reset to a background only transition after a transition.</li> </ul>  |
| <b>Next Transition</b>         | <p>Have the next transition buttons on the control panel latch when pressed (toggle). This setting is unique to the control panel.</p> <ul style="list-style-type: none"> <li><b>Off</b> — press and hold all the buttons you want included in the next transition. All buttons must be pressed at the same time.</li> <li><b>Toggle</b> — press a button to toggle it on or off as being included in the next transition.</li> </ul>   |
| <b>Remove Keys</b>             | <p>Have a key removed from the next transition after it has been transitioned off-air using key Cut or Trans buttons. This allows you to transition a key off-air in an emergency and not have it accidentally transitioned back on-air with the next transition. This setting is for the frame.</p> <ul style="list-style-type: none"> <li><b>Off</b> — key can remain part of the next transition when it is independently transitioned off-air.</li> <li><b>On</b> — key is removed as part of the next transition when it is independently transitioned off-air.</li> </ul> |
| <b>Background Double Press</b> | <p>Have a double-press of the next transition background button select the background and all on-air keys as part of the next transition. This setting is unique to the control panel.</p> <ul style="list-style-type: none"> <li><b>Ignore</b> — ignore the double-press of the next transition background button.</li> <li><b>Transition Clear</b> — set the next transition to include the background and only the on-air keys. If an off-key is selected as part of the next transition it is deselected.</li> </ul>  |

| Personality                        | Description   |
|------------------------------------|---|
| <b>ME Auto Trans Double Press</b>  | <p>Set what action is performed when the auto transition button is pressed again during a transition. This setting is for the frame.</p> <ul style="list-style-type: none"> <li><b>Halt Forward</b> — the transition is halted and then continues in the same direction when the transition button is pressed again.</li> <li><b>Reverse</b> — the transition immediately reverses directions when the transition button is pressed.</li> <li><b>Halt Reverse</b> — the transition is halted and then reverses directions when the transition button is pressed again.</li> <li><b>Cut</b> — the transition immediately cuts back to the initial state when the transition button is pressed.</li> <li><b>Ignore</b> — the button press is ignored and the transition continues.</li> </ul>                 |
| <b>Key Auto Trans Double Press</b> | <p>Set what action is performed when the independent key auto transition button is pressed again during a transition. This setting is for the frame.</p> <ul style="list-style-type: none"> <li><b>Halt Forward</b> — the transition is halted and then continues in the same direction when the transition button is pressed again.</li> <li><b>Reverse</b> — the transition immediately reverses directions when the transition button is pressed.</li> <li><b>Halt Reverse</b> — the transition is halted and then reverses directions when the transition button is pressed again.</li> <li><b>Cut</b> — the transition immediately cuts back to the initial state when the transition button is pressed.</li> <li><b>Ignore</b> — the button press is ignored and the transition continues.</li> </ul> |
| <b>Roll Clip</b>                   | <p>Set whether the roll clip feature is always on, or must be turned on manually. This setting is for the frame.</p> <ul style="list-style-type: none"> <li><b>User</b> — the roll clip feature must be turned on manually.</li> <li><b>Force</b> — the roll clip feature is always on.</li> </ul>  |

## Color Schemes

The buttons on the control panel glow with different colors specific to their state, function, and assignment. This color can be selected from a list of pre-set color schemes, or a custom color can be selected. Up to four (4) custom color schemes can be saved on the switcher.

### To Select a Color Scheme

ME, MiniME™, MultiScreen, aux buses, and keyers can be set to different colors by loading

one of the pre-installed color scheme. This setting is unique to the control panel.

1. Click **Navigation Menu > Personality > Color Scheme**.

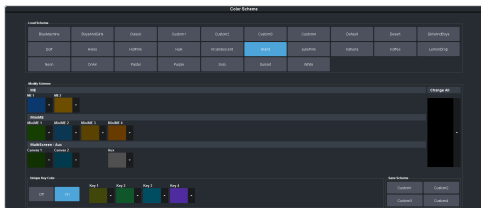

2. In the **Load Scheme** area, select the color scheme you want to use on the control panel.

**Tip:** You can load a pre-loaded color scheme and then modify the colors and save it as a custom color scheme. You cannot save your modifications back to the pre-loaded color scheme.

## To Create a Custom Color Scheme

A custom color scheme can be created and used instead of one of the pre-loaded color schemes. This setting is unique to the control panel.

1. Click **Navigation Menu > Personality > Color Scheme**.

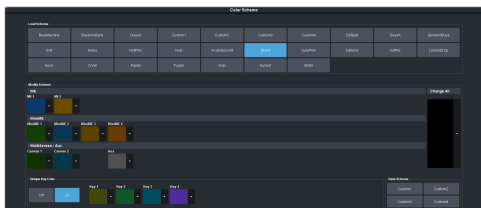

2. In the **Modify Scheme** area, click the ME, MiniME™, MultiScreen, or aux that you want to change the color for.

**Tip:** Click **Change All** to change the color of all the areas at once. They will all use the selected color.

3. Use the color picker to select the new color you want to use and click **Ok**.

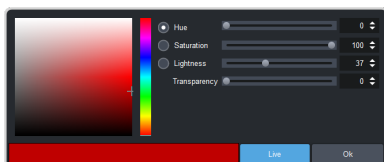

**Tip:** Click **Live** to have the color changes update in real time on the control panel.

4. In the **Unique Key Color** area select how you want the keyer buttons on the control panel to be colored.

- **Off** — the keyer buttons use the same color as their ME, MiniME™, or MultiScreen.
- **On** — the keyer buttons use the unique colors assigned to each key. Click the key that you want to change the color for and use the color picker to change the color.

5. Click a **Custom X** button to store your color scheme to that location.

6. Click **Yes**.

## Bus Maps

Any video input can be mapped to any source button on the control panel using a bus map. Each source button can have two inputs assigned (a standard source and a shifted source).

### To Create a Bus Map

The bus map assigns video sources to the buttons on the control panel.

**Note:** The bus map is unique to the control panel (Master, Sat 1, Sat 2, or Sat 3) and can only be set for that control panel.

1. Click **Navigation Menu > Personality > Bus Map**.

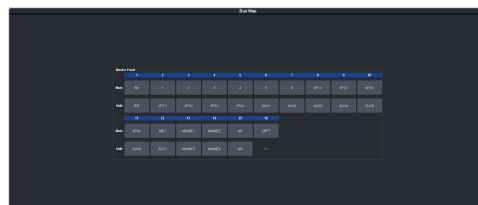

2. Click the source button that you want to assign a source to and select the source you want to assign to that button.

**Tip:** You must assign a button to the Shift function to be able to access those source buttons on the control panel.

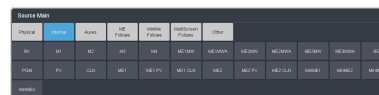

## User Buttons

These buttons can be assigned to a number of functions, including ME and key selections, custom control, and memories. The number and position of the buttons on the control panel depend on the model of your control panel.

If a button is assigned to an ME, aux bus, MiniME™, MultiScreen, or chroma key, you can press and hold the button to be able to select a

different ME, aux bus, MiniME™, MultiScreen, or chroma key from the key bus. If the user button is assigned to an Aux, it will allow you to select a different Aux.

## To Set A User Button

1. Click **Navigation Menu > Personality > User Select.**

**Note:** The menu only shows the user buttons that are available on your control panel.

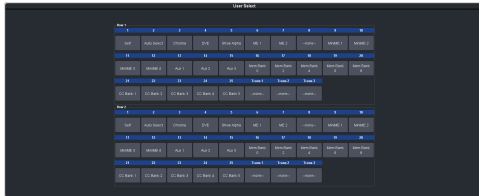

2. Click the user button that you want to assign a function to and select the function you want to assign to that button.

**Tip:** Each row on your control panel can have a separate set of user button assignment. These settings are tied to the row, and not the ME that is assigned to that row.

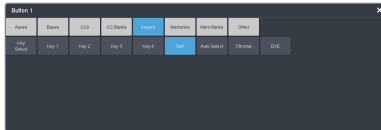

**Note:** The functions that are available on your switcher may differ depending on the options you have installed and how your switcher is configured.



# GPI Control

General Purpose Interface (GPI) is a high/low voltage signalling protocol that allows the switcher to send simple commands to an external device, or receive commands from a device. Each pin on the GPI is set as either high (+5 Volts), or low (0 Volts), and it is the switching between high and low that sends commands to the external device, or to the switcher.

## GPI Trigger Types

There are four trigger types supported by the switcher. These can be either output triggers, or input triggers.

**Table 4: Trigger Types**

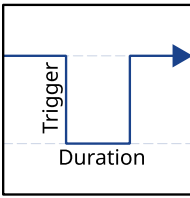
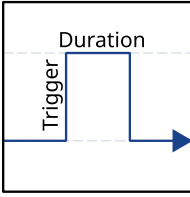
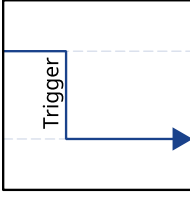
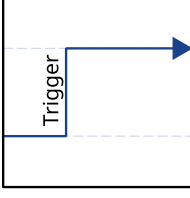
| Trigger    | Description  |   |
|------------|--|---|
| Low Edge   | The output level is set high, and momentarily goes low for the trigger.  |   |
| High Edge  | The output level is set low, and momentarily goes high for the trigger.  |  |
| Low Level  | The output level toggles from the base high level to the low level. The output signal remains at this level until reset. |  |
| High Level | The output toggles from the base low level to the high level. The output signal remains at this level until reset.       |  |

## GPI Setup

Each GPI pin on the switcher can be configured as either an input, or an output. By default, all GPIs are set as inputs.

## To Set Up a GPI Input

The switcher requires a Low Edge GPI input trigger.

1. Click **Navigation Menu > Configuration > GPIO**.

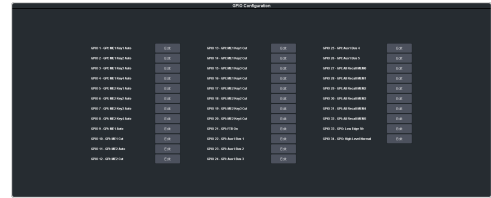

2. Click **Edit** for the GPI that you want to configure as an input.
3. Click **GPI**.



4. Click the **Event** button for the action you want to assign to the selected GPI input pin.

| Setting    | Description  |
|------------|--|
| --none--   | No action is taken   |
| CC         | Run a specific custom control: <ol style="list-style-type: none"> <li>Enter the custom control bank in the <b>Bank</b> field.</li> <li>Enter the custom control in the <b>CC</b> field.</li> </ol>                           |
| Mem Recall | Recall a memory on all MEs: <ul style="list-style-type: none"> <li>Enter the memory to recall in the <b>Mem</b> field.</li> </ul>  |
| FTB        | Perform a transition to black on the program ME that also takes all keys off-air. The source originally selected on program is selected on preset  |
| ME Cut     | Perform a background cut on the selected ME: <ul style="list-style-type: none"> <li>Click an <b>ME</b> button to select the ME, MiniME™, or MultiScreen.</li> </ul>  |
| ME Auto    | Perform a background auto transition on the selected ME: <ul style="list-style-type: none"> <li>Click an <b>ME</b> button to select the ME, MiniME™, or MultiScreen.</li> </ul>  |
| Key Cut    | Perform a key cut on the selected ME and key: <ol style="list-style-type: none"> <li>Click an <b>ME</b> button to select the ME, MiniME™, or MultiScreen.</li> <li>Click a <b>Key</b> button to select the keyer.</li> </ol> |

| Setting         | Description   |
|-----------------|---|
| <b>Key Auto</b> | Perform a key auto transition on the selected ME, MiniME™, or MultiScreen and key: <ol style="list-style-type: none"> <li>Click an <b>ME</b> button to select the ME, MiniME™, or MultiScreen.</li> <li>Click a <b>Key</b> to select the keyer number.</li> </ol> |
| <b>Aux Xpt</b>  | Select a video source on an aux bus: <ol style="list-style-type: none"> <li>Click the <b>Aux</b> button and select the aux bus.</li> <li>Click the <b>Source</b> button and select the video source.</li> </ol>   |

## To Set Up a GPI Output

A GPI output can be set as a Normal GPI output, or as a Tally output. As a tally output, the GPI output must be assigned to a video source. A GPI output in tally mode can still be used as a normal GPI output.

1. Click **Navigation Menu > Configuration > GPIO**.

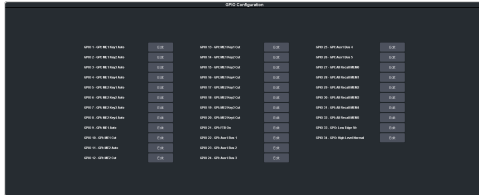

2. Click **Edit** for the GPI that you want to configure as an output.
3. Click **GPO**.

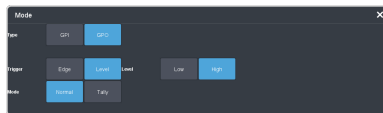

4. Click a **Level** button to select whether you want the GPI to trigger low (**Low**), or high (**High**).
5. Click a **Trigger** button to select whether you want to use an edge trigger (**Edge**), or a level trigger (**Level**).
6. For edge triggers, use the **Duration (fr)** slider to set the length of time (in frames) that the GPI edge output remains triggered.
7. For level triggers, click a **Mode** button to select how you want to GPI output to act.
  - **Normal** — when assigned to a video source and RollClip is active, will trigger with the source going on-air, and back with the source going off-air (pre-delay

values are only used when the source is going on-air)

- **Tally** — when assigned to a video source, will trigger with the source going on-air, and back with the source going off-air (RollClip and pre-delay values are ignored)

## GPI Output Triggers

Each video source can have a GPI output assigned to it. This GPI can be used to trigger an external device, such as a video server, to play the cued clip when the video sources from the video server are taken on-air.

A GPI trigger can be set up to occur automatically any time the video source is transitioned on-air, or it can be triggered manually.

*Note: The Next Button Secondary Function must be set to GPO to be able to trigger a GPI output manually using the **NEXT** button on the control panel.*

### Keep the following in mind:

Keep the following in mind when working with GPI output triggers:

- The **Roll Clip** must be set to **On** to trigger a GPI output with a transition.
- Edge triggered GPI outputs remain triggered for the configured duration.
- Level triggered GPI outputs toggle between high and low each time they are triggered.

## To Assign a GPI Output to a Video Source

You can set a pre-delay, or pre-roll, that will specify when the GPI is triggered in relation to taking the video source on-air. This is useful for VTR pre-roll delay and other situations where an input source is not immediately ready to be taken to air.

*Note: The roll clip function must be set to on to trigger the GPI output with a transition.*

1. Click **Navigation Menu > Configuration > Inputs > External** if you are setting up a physical input, or **Internal** if you are setting up an internal input.
2. Click the **GPO** button for the video source that you want to assign a GPI output to.

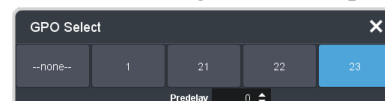

---

When you select this source on a bus, the GPI output will trigger automatically.

**Note:** *Not all sources can have a GPI assigned to them.*

3. Click the **GPO** button for GPI output that you want to assign to the selected video source. A GPI must be configured as an output to appear on the list.
4. In the **Predelay** field, enter the pre-delay interval (in frames) that the switcher waits after the GPI output is triggered before taking the source on-air.

# Live Edit Decision Lists (LiveEDL)

Edit Decision Lists are files used by non-linear editing (NLE) suites to aid in post-production. Your switcher can capture EDL data in a file that you load into your NLE suite.

## LiveEDL Setup

You can configure your switcher to trigger multiple GPI outputs at the start, end, or both, of an EDL data capture to trigger video servers that are recording the feeds coming into the switcher. The EDL data from the switcher can then be paired with the feeds from the video servers, using the timecode data, in the NLE suite to edit or re-cut the show.



**Important:** A control panel is required to configure this feature. If you do not have access to a physical control panel, the SoftPanel can be used.

You can also set a pre-delay for each GPI output. EDL data capture does not begin until the highest pre-delay has passed. This is useful when the switcher needs to wait for external equipment to become ready. The example below shows the effects of various triggering and pre-delay settings.

## To Set the LiveEDL Behavior



**Important:** A control panel is required to perform this procedure. If you do not have access to a physical control panel, the SoftPanel can be used. The position of items on the menus on the SoftPanel may not match those of a physical panel.

1. Press **MENU > System > NEXT > NEXT > NEXT > LiveEDL Config**.
2. Use the **GPO** knob to select the GPI output that is connected to your video server. The GPI must be configured as a GPI output before it can be selected.
3. Use the **Triggr** knob to select when the GPI output is triggered.
  - **Off** — GPI is not triggered
  - **Start** — GPI output is triggered at the beginning of the EDL capture
  - **Stop** — GPI output is triggered at the end of the EDL capture
  - **Both** — GPI output is triggered at the beginning and end of the EDL capture

If Start or Both is selected, you must set the pre-delay for the GPI.

4. Use the **PreDly** knob to select the pre-delay interval (in frames) that the switcher waits after the GPI output is triggered before starting to capture EDL data.

## Timecode Setup

The switcher uses timecode data to mark the EDL file so that it can be used in the non-linear editing suite along with the feeds from the video servers. The timecode data can be either from an external timecode generator, or internally generated. An offset can be applied to both timecode sources.

For an external timecode, an LTC generator must be connected to the LTC port on the back of the frame.

## To Confirm External LTC Signal

If you have an external linear timecode generator connected to the switcher, you can confirm that the switcher is receiving timecode data.



**Important:** A control panel is required to perform this procedure. If you do not have access to a physical control panel, the SoftPanel can be used. The position of items on the menus on the SoftPanel may not match those of a physical panel.

1. Click **Navigation Menu > Status**
2. Confirm that the information shown in the **Timecode** field matches the timecode from the timecode generator.

If required, an offset can be applied to the incoming timecode data.

## To Set Up Communications with a TSC-9902



**Important:** A control panel is required to perform this procedure. If you do not have access to a physical control panel, the SoftPanel can be used. The position of items on the menus on the SoftPanel may not match those of a physical panel.

1. Press **MENU > System > NEXT > NEXT > Device Configure**.
2. Press the **Add** knob.
3. Use the **Slot** knob to select **SP** (serial port).
4. Use the **Type** knob to select **LTC**.
5. Press **NEXT**.
6. Use the **SubType** knob to select **LTC\_#.#**.

7. Press the **SubType** knob.
8. Press the **Confirm** knob to save your settings.

## To Set the LTC Timecode Source

If you are using an external timecode generator, an offset, or delay, is applied to the incoming timecode signal before it is stored in the LiveEDL data file. If you are using an internal timecode, the offset is the starting time that the switcher uses for the timecode that is stored in the LiveEDL file.



**Important:** A control panel is required to perform this procedure. If you do not have access to a physical control panel, the SoftPanel can be used. The position of items on the menus on the SoftPanel may not match those of a physical panel.

**Note:** If a valid timecode signal is detected on the LTC port on the frame, the external timecode will be used even if an internal timecode is set.

1. Press **MENU > System > NEXT > NEXT > NEXT > LiveEDL Config > NEXT**.
2. Use the **Offset** knob to select the source of the timecode data you want to use.
  - **Ext.** — the timecode data received on the LTC port is used
  - **Int.** — an internal timecode is generated
3. Set the timecode offset for an External timecode as follows:
  - a) Use the **LTCOff** knob to select the offset, in frames, that you want to delay the incoming timecode signal by.
4. Set the starting time for an Internal timecode as follows:
  - a) Use the **Field** knob to select the hours, minutes, or seconds that you want to adjust.  
The timecode is shown in the [HH:MM:SS] format.
  - b) Use the **Value** knob to set the starting time in the selected field.

## LiveEDL Data Capture

Capturing EDL data is manually started and stopped from the switcher. When you select to start capturing EDL data, and GPI outputs set to trigger on start are triggered. If a pre-delay has been set for the GPIs, the switcher does not start capturing EDL data until the pre-delay time has finished.

When you stop capturing EDL data, you have the option to delete the data, or save it to a USB drive. You can also connect to the switcher via FTP and download the files directly to your editing suite. Use the username `liveedl` and password `password` to create the FTP connection to the switcher.

### Keep the following in mind:

Keep the following in mind when reviewing the EDL data from the switcher:

- When a MediaWipe is selected as the transition type, the switcher records the transition duration as the cut point frame multiplied by two (2). This is to ensure that the cut point is recorded accurately.
- If you used more than one ME, or Aux bus, in your shot, a separate EDL file is saved for each ME and Aux bus. The ME re-entry is shown as being selected on the first ME, and the source selections on the second ME are saved to the separate LiveEDL file. Aux bus information is only stored to a LiveEDL file when the Aux bus is not in fixed mode.

## To Start Capturing EDL Data

The EDL data can be stored to one of 1000 LiveEDL files stored on the switcher. A separate file is created for each ME when the additional MEs are used.



**Important:** A control panel is required to perform this procedure. If you do not have access to a physical control panel, the SoftPanel can be used. The position of items on the menus on the SoftPanel may not match those of a physical panel.

1. Press **MENU > User > LiveEDL**.
2. Use the **Start** knob to select the LiveEDL file on the switcher that you want to store the EDL data to.  
If the LiveEDL file already contains data, you are given the option to delete the data, or save it to a USB.
3. Press the **Start** knob to start recording.

## To Stop Capturing and Save EDL Data



**Important:** A control panel is required to perform this procedure. If you do not have access to a physical control panel, the SoftPanel can be used. The position of items on the menus on the SoftPanel may not match those of a physical panel.

1. Press **MENU > User > LiveEDL**.

- 
2. Press the **Stop** knob to stop recording.
  3. Save the EDL data to a USB as follows:
    - a) Insert your USB drive into the USB Port on the switcher. You must wait 5 seconds for the switcher to recognise the USB drive.
    - b) Press the **Save** knob.
    - c) Press the **Confirm** knob to store the LiveEDL file to the USB drive.



## ViewControl (HD Only)

The ViewControl interface through DashBoard allows you to coordinate the control over the Carbonite switcher, XPression Live Graphics System, and the BlackStorm Playout Server all through a touchscreen interface. Through ViewControl you can select sources, perform transitions, and run custom controls.

### Keep the following in mind:

Keep the following in mind when working with ViewControl

- Only the Video Processor MultiViewer can be used for ViewControl.
- ViewControl requires DashBoard 5.1, or later.
- Only the sources assigned to the MultiViewer boxes are available for direct selection. Custom controls can be used to select other sources.
- A running custom control, or a custom control that is paused or held, are not shown on the ViewControl interface.
- The control panel does not follow key and bus selections made on ViewControl.

## ViewControl Overview

The ViewControl interface provides quick access to a number of custom control buttons as well as the transition functionality of the switcher.

### Custom Control Buttons

The custom control buttons can be assigned to any custom control on the switcher and given unique names and icons. The button groups on the left (shown below) are organized into groups, or tabs.



### Bus Selection Buttons

The bus selection buttons allow you to select the different buses on different ME outputs of the switcher.

To select a source on a bus, press the bus selection button, and press the MultiViewer box for the source you want to select. For example, to select camera 1 on ME 2 Key 3, press **M2 K3** and then press the box for the camera 1 source.

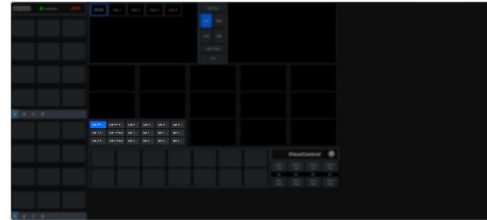

### Keyer Transition Buttons

The Keyer Transition buttons allow you to perform a cut or dissolve of the keys on the Program bus, without having to include them as part of the next transition. These buttons act the same as the Keyer Transition Buttons on the control panel.

*Tip: The Cut buttons turn red when a key is on-air.*

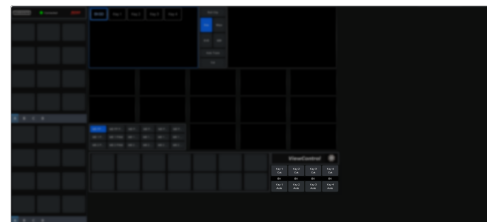

### Transition Buttons

The transition buttons allow you to select what is included in the next transition, what type of transition is to be performed, and perform the transition. These buttons function similarly to the buttons in the Transition Area on the control panel.

*Tip: The Transition Buttons on ViewControl only control the transition area of ME P/P. To control another ME you can create a custom control to perform the effect you want and assign it to one of the custom control buttons.*

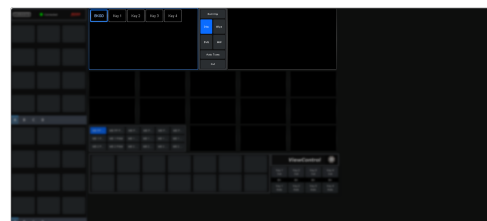

### Custom Control Button Setup

When you assign a custom control to a button, you can give that button a unique name and

assign an icon to it. The images for the icons must be on a USB drive in the frame when you assign them. Once assigned the icons are stored in the frame and the USB can be removed. Each of the tabs can be named.

The configuration of the tabs and custom control assignment to buttons are stored with the switcher personality settings.

## To Set up the Custom Control Buttons

You must assign custom controls from the switcher to the buttons on ViewControl.

If you want to assign icons to the custom control buttons, you must have the images you want to use for the icons stored on a USB drive installed in the frame. After the images have been assigned you can remove the USB drive.

1. Click the  button in the upper right corner of the window.

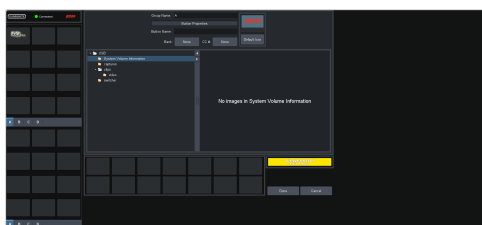

2. Press the custom control button that you want to set up.
3. Enter a name for the button in the **Button Name** field.

**Tip:** You can change the name of a tab by selecting a button on the tab and then entering a new name in the **Group Name** field.

4. Click the **Bank** button and select the number of the bank you want to select a custom control from.
5. Click the **CC X** button and select the number of the custom control you want to assign to the button.
6. Navigate the files on the USB drive and click the image you want to assign as the icon for the button.

**Tip:** Press **Default Icon** to switch back to the default icon.

7. Set up additional custom control buttons as required.
8. Press **Done** when you are done setting up custom control buttons.

## Connecting ViewControl

ViewControl combines an overlay image from DashBoard with a custom MultiViewer output from the switcher to generate the interface. This requires some external SDI/HDMI video conversion equipment, as well as a touchscreen display.

**Note:** An input FSFC should be applied to the input you are using for ViewControl.

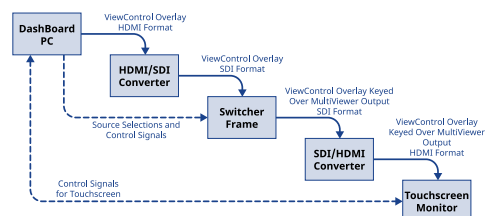

The following connections are required for ViewControl:

- ViewControl is only supported in 1080i or 720p. The switcher must be operating in one of these formats for ViewControl to operate.
- Set the output resolution of the DashBoard computer to either 1920×1080 or 1280×720.
- Use an HDMI to SDI converter to take the output of the DashBoard computer and put it into a resolution that the switcher can use. Ensure that the resolution is not changed.
- Apply a FSFC to the input that is coming from the DashBoard computer.
- Set up a MultiViewer to use a ViewControl layout.
- Connect the USB cable for the touchscreen to the DashBoard computer.

## To Set Up the MultiViewer for ViewControl

ViewControl integrates the MultiViewer output of the switcher with a graphical overlay from DashBoard to provide live video in the ViewControl windows. The MultiViewer must be configured to properly align the video for the buttons on ViewControl.

**Note:** The switcher must be operating in a 1080p, 1080i, or 720p video format for ViewControl to operate.

**Note:** Only the Video Processor MultiViewer can be used for ViewControl.

1. Click **Navigation Menu > Configuration > MultiViewers** and click **MultiViewer 1**.

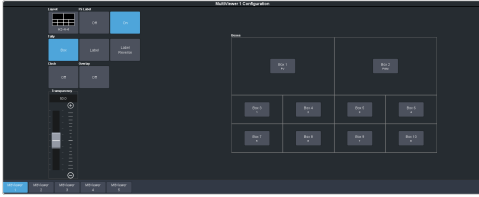

2. Click the **Layout** button and select a ViewControl layout.
  - **VCtrlT** — (**ViewControl Top**) places the boxes at the top of the screen.
  - **VCtrlB** — (**ViewControl Bottom**) places the boxes at the bottom of the screen.

*Tip: If you want to create a custom ViewControl layout, you can use one of the other MultiViewer layouts to create the look you want, and use PanelBuilder in DashBoard to assign functionality to the layout. Sources can be hidden from a layout by assigning black to the box. For more information on PanelBuilder, refer to the DashBoard documentation.*

3. Click the **Overlay** button and click **On** to turn the overlay on.
4. Click the **Source** button for the overlay input from DashBoard. This is keyed over the MultiViewer layout.
5. Use the **Clip** slider to adjust the clipping of the overlay source.

At **0%** the overlay source is completely opaque, and at **100%** it is completely transparent.
6. Click on one of the **Boxes** buttons and set up how that box appears on the MultiViewer.
7. Click on the source you want to select for the box.

*Note: The large box on the left should always be assigned to **PV** and the large box on the right assigned to **PGM**.*

---

# MultiPanel

Each frame supports up to 4 independent control connections (Master, Satellite 1, Satellite 2, and Satellite 3/SoftPanel). Each connection can be from a control panel, DashBoard, or a combination of the two. Add devices on the same control connection mirror each other.

The independent control connections are selected by the port you connect to on the frame. Multiple panels and DashBoard connections can connect on the same port, but they will all share the same permissions and mirror each other for control.

- **Master Panel** — 5253
- **Satellite 1** — 5255
- **Satellite 2** — 5256
- **Satellite 3/SoftPanel** — 5257

## Keep the following in mind:

Keep the following in mind when working with MultiPanel:

- SoftPanel shares the permissions of the Master Panel.
- The assignment of the panel ID is done from the control panel.
- Control panel specific personality settings are stored on the frame for the panel ID and are not tied to the control panel.
- DashBoard automatically follows the master panel but will ignore permissions set for the master panel.
- If you change switcher modes, the MultiPanel permissions may have to be set again.
- An undo of a memory recall ignores panel permissions and will undo the last memory recalled from any panel.
- Bus maps are specific to each control panel. Creating or updating a bus map for one control panel does not change the bus map on another control panel.
- Custom controls ignore control panel permissions and will run events on an ME, MiniME™, or MultiScreen that the control panel does not have permission for.

## To Set Up MultiPanel Permissions

1. Click **Navigation Menu > Configuration > System > MultiPanel**.

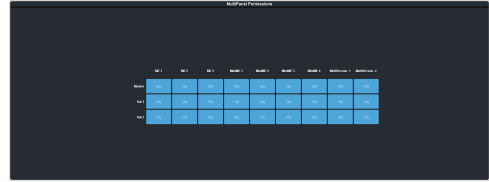

2. Click a **Master, Sat 1, or Sat 2** button to select whether that control connection has access to that resource.

**Note:** SoftPanel and Master share the same permissions.

**Note:** A control panel must have permission to at least one ME, MiniME™, or MultiScreen.

# Diagnostics

Switcher status menus and error conditions, installed options, calibration, diagnostics, and logs.

## Switcher Status

The status menu shows information for various components of the frame.

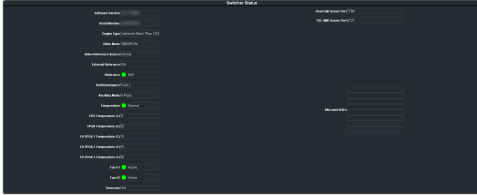

- **Software Version** — the current version of the software running on the switcher.
- **Serial Number** — the serial number of the frame.
- **Engine Type** — the model of frame.
- **Video Mode** — the video format that the switcher is operating in.
- **Video Reference Source** — the source of video reference to the switcher (internal/external).
- **External Reference** — the video format of the external reference, if connected.
- **Reference** — status of whether the switcher has locked to the reference format.
- **Field Dominance** — the switching field.
- **Ancillary Mode** — how ancillary data is handled (strip or pass).
- **Temperature** — status of the ambient temperature in the frame.
- **CPU Temperature (C)** — the temperature of the frame CPU in degrees Celsius.
- **FPGA Temperature (C)** — the temperature of the frame video processor FPGA in degrees Celsius.
- **IO FPGA Temperature (C)** — the temperature of the frame I/O processor FPGA in degrees Celsius.
- **Fan #1** — speed and status of fan 1 in the frame.
- **Fan #2** — speed and status of fan 2 in the frame.
- **Timecode** — the current timecode being received by the switcher.
- **RossTalk Server Port** — the network port that the switcher is listening on for RossTalk commands.

- **TSL UMD Server Port** — the network port that the switcher is listening on for TSL UMD commands.
- **Allocated DVEs** — where DVE channels are allocated in the switcher.

## Switcher Logs

Switcher logs can be used to identify and diagnose problems with the switcher. Use this information when contacting Ross Video Technical Support.

### To Copy Logs To a USB

Switcher logs can be stored onto a USB to be sent to technical support to diagnose problems with your switcher.

*Note: Logs must be copied before a reboot or power-cycle of the switcher, or the information in them will be lost.*

1. Insert USB drive into the USB port on the frame. Wait 5 seconds after inserting the USB drive before using it.
2. Click **Navigation Menu > Configuration > Diagnostics**.

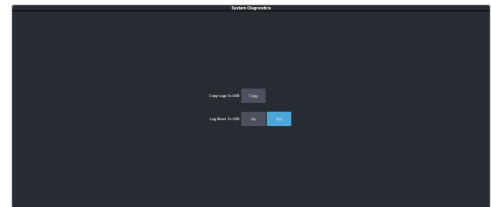

3. Click the **Copy Logs To USB** button to copy the switcher logs to the USB drive.

*Tip: You can have logs stored directly to the USB drive. Click a **Logs Direct to USB** button to select **Yes**.*

The logs have been copied into the \switcher directory on the USB drive.

## Diagnostics

Diagnostics consist of a number of tests that are used to confirm the functionality of your equipment.

### Frame DIP Switches

There are a number of DIP switches inside the frame that are used to diagnose the operation of the switcher.

**Table 5: Carbonite/Carbonite Black Frame DIP Switches**

| DIP | Description  |
|-----|--|
| 1   | This DIP switch forces a RAM test every time the switcher is powered on. It is in the up (off) position by default.  |
| 2   | This DIP switch is unused and should be left in the default up (off) position.   |
| 3   | This DIP switch is used to set the IP address of ethernet port on the frame to the default value ( 192.168.0.123 ). It must be in the up (off) position to set another IP address for the frame. |
| 4   | This DIP switch prevents software upgrades. It must be in the up (off) position to upgrade the switcher.   |
| 5   | This DIP switch is unused and should be left in the default up (off) position.   |
| 6   | This DIP switch is unused and should be left in the default up (off) position.   |
| 7   | This DIP switch is unused and should be left in the default up (off) position.   |
| 8   | This DIP switch is unused and should be left in the default up (off) position.   |

### To Run the Tally Test

The Tally Test turns all tallies off, and then turns each tally on consecutively. There is a three (3) second delay between each tally being toggled on. Once the last tally has been turned on, all the tallies blink on and off three times.



**Important:** A control panel is required to perform this procedure. If you do not have access to a physical control panel, the SoftPanel can be used. The position of items on the menus on the SoftPanel may not match those of a physical panel.

1. Press **MENU > System > NEXT > NEXT > Diagnostic Tests (Diag Tests on Carbonite Black) > NEXT > NEXT > Tally Test.**  
All tallies are turned off, and then each tally is turned on consecutively. There is a three (3) second delay between each tally being toggled on. Once the last tally has been turned on, all the tallies blink on and off three times.
2. Press **MENU** to end the test.

### To Run the GPI Input Test



**Important:** A control panel is required to perform this procedure. If you do not have access to a physical control panel, the SoftPanel can be used. The position

of items on the menus on the SoftPanel may not match those of a physical panel.

1. Press **MENU > System > NEXT > NEXT > Diagnostic Tests (Diag Tests on Carbonite Black) > NEXT > NEXT > GPI Test.**  
The second line of the menu show the state of all GPI input pins as High or Low.
2. Press **MENU** to end the test.

### To Run the GPI Output Test



**Important:** A control panel is required to perform this procedure. If you do not have access to a physical control panel, the SoftPanel can be used. The position of items on the menus on the SoftPanel may not match those of a physical panel.

1. Press **MENU > System > NEXT > NEXT > Diagnostic Tests (Diag Tests on Carbonite Black) > NEXT > NEXT > GPO Test.**  
All GPI outputs are turned off, and then each one is turned on consecutively. There is a three (3) second delay between each GPI output being triggered. Once the last tally has been triggered, all the GPI outputs blink on and off three times.
2. Press **MENU** to end the test.

### Error Messages

The switcher will show an error message on the control panel display when a problem is detected.

The following error messages may appear on the control panel display when starting your switcher.

**Table 6: Switcher Error Messages**

| Error   | Description  | Solution  |
|---|--|---|
| <b>DDR 0 Not Found; DDR 1 Not Found; or DDR 0 &amp; 1 Not Found</b> | There is a problem with the switcher DDR memory. The switcher may be used but many features will be limited or disabled. | Re-start your switcher. If the problem persists, contact Ross Video Technical Support for assistance. |
| <b>Panel/Frame Mismatch</b>   | Your switcher control panel is connected to the wrong frame type.  | Connect your switcher control panel to the proper frame and re-start the switcher.                    |



| Error                                    | Description  | Solution   |
|--|--|--|
| <b>Upgrade PMC?</b>                      | Your switcher requires a Panel Module Controller (PMC) upgrade as part of a software upgrade. The switcher may be used without the PMC upgrade but may respond in an unpredictable manner.           | Allow the PMC upgrade to proceed. Contact Ross Video Technical Support for assistance if you are unsure about upgrading your switcher.   |
| <b>Unknown panel type Please upgrade</b> | The frame does not recognise the control panel. This could be caused by an unsupported panel being connected to the frame, or a problem with the panel module controlled or the configuration files. | Ensure that you have the correct control panel connected to the frame. If the problem persists, download the latest upgrade file from and force an upgrade of the switcher. Contact Ross Video Technical Support for assistance if you are unsure about upgrading your switcher. |

## Switcher Reset

If required, the switcher can be reset to return it to a user-defined default setting (RState), or the factory default state. A reset can be performed for the entire switcher, or individual components, such as keys.

### Custom Reset Settings (RState)

You can customize many of the default switcher parameters and save them as a user-defined reset settings. These custom reset settings can then be recalled when you want to return the switcher to a previous state.

#### To Save a Custom Reset Setting

The Custom Reset Setting, or RState, saves how you want the switcher to be configured when it powers up, or when you recall the RState manually.

1. Click **Navigation Menu > Live Assist > Memory > RState**.



2. Click **AuxX, MediaX, MiniMEX, and MultiScreenX** to select the buses or channels that are reset with a switcher reset.

*Tip: Click the **All** button to select or de-select all the items in that category.*

3. Click **Save RState** and **Yes**.

#### To Load a Custom Reset Setting (RState)

The Custom Reset Setting, or RState, is recalled every time the switcher is powered on, or it can be recalled manually.

1. Click **Navigation Menu > Live Assist > Memory > RState**.
2. Click **Load RState** and **Yes**.

*Tip: Click **Default RState** to load the default RState settings.*

## Factory Default Settings

You can restore all or part of the switcher to the factory default state. A factory default returns all installation and personality settings are reset.

#### To Factory Reset the Switcher

Return the switcher to the factory default settings.

1. Click **Navigation Menu > Configuration > System > Reset**.

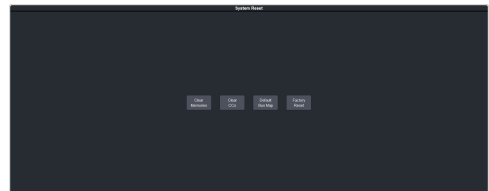

2. Click a reset or clear button to return that feature to the factory default state.
  - **Clear Memories** — clear all memory registers on the switcher.
  - **Clear CCs** — clear all custom controls on the switcher.
  - **Default Bus Map** — return the bus map to the default mapping.
  - **Factory Reset** — return the installation and personality registers to the default settings.

# Specifications

Switcher resources, video specifications, power rating, and port pinouts.

## Carbonite Black Resources

The number of resources specific to your switcher depends on the options installed.

| Resource                                      | Carbonite Black Carbonite Black+ Carbonite Black+ 12G |       |  |
|---|---|-------|--|
|   |   |       |  |
| 2D DVE Channels per ME (Max/Min) <sup>1</sup> | 8/4   |       |  |
| Aux Buses                                     | 20  |       |  |
| Chroma Keys per ME                            | 2 (floating)  |       |  |
| Custom Controls                               | 256 (8 Banks × 32 CCs)                                |       |  |
| Max Events per CC                             | 998   |       |  |
| FSFCs (Max/Min) <sup>1</sup>                  | 6/0   | 36/36 |  |
| GPI I/Os                                      | 34  |       |  |
| Keyers per ME                                 | 4   |       |  |
| Matte Generators per ME                       | 2   |       |  |
| Media-Store Channels                          | 4   |       |  |
| Media-Store CACHE                             | 8 GB  |       |  |
| Memories per ME                               | 100   |       |  |
| MEs (max)                                     | 3   |       |  |
| MiniME™ Engines                               | 4   |       |  |
| MultiScreen Generators                        | 2 <sup>2</sup>  |       |  |
| MultiViewer Boxes                             | 16  |       |  |
| MultiViewer Layouts                           | 39  |       |  |
| MultiViewer Outputs                           | 2   | 5     |  |
| Pattern Generators per ME                     | 2   |       |  |
| Tallies                                       | 34  |       |  |
| SDI Video Inputs                              | 36  |       |  |
| SDI Video Outputs                             | 22  | 25    |  |
| Frame IP                                      | 192.168.0.123   |       |  |
| Panel/CarboNET IP                             | 192.168.0.129   |       |  |

### Notes:

<sup>1</sup> The number of DVE channels and FSFCs that are available depends on the switcher mode you are in. This table assumes that all options are installed.

<sup>2</sup> Each MultiScreen consumes MiniME™ engines to generate the output. The number of MultiScreen outputs that are available depends on the number of MiniME™ engines that are available.

## Environmental Characteristics

| All Switchers             |  |
|---------------------------|--|
| Ambient Temperature Range | Operating: 0 - 40°C (32 - 104°F)<br>Storage: -20 - 85°C (-4 - 185°F) |
| Frame Cooling             | Active, Front-to-Back airflow  |

## Video Input Specifications

| Input Specification                         | Value                              |
|---|------------------------------------|
| Equalization (using Belden 1694 cable)      | >50m @ 3Gb/s                       |
|   | >100m @ 1.5 Gb/s                   |
|   | >300m @ 270 Mb/s (5°-40°C)         |
| Impedance                                   | 75 ohm, terminating                |
| Video Inputs, SDI                           | SMPTE 259M/292M/424M (non-looping) |
| Reference Inputs (non-terminating, looping) | Standard Definition — analog black |
|   | High Definition — tri-level sync   |

## Video Output Specifications

| Output Specification       | Value                                 |
|----------------------------|---------------------------------------|
| Return Loss                | <-23dB @ 1.5GHz                       |
|                            | <-18dB @ 3GHz                         |
| Rise and Fall Time         | 800ps ±10% (SD)                       |
|                            | 240ps ±10% (HD)                       |
| Signal Level               | 800mV ±10%                            |
| DC Offset                  | 0 Volts                               |
| Overshoot                  | <10%                                  |
| Video Outputs, SDI HD Mode | 10-bit SMPTE-292M/424M serial digital |

## Audio Specifications

| Specification | Value                            |
|---------------|----------------------------------|
| Audio Depth   | 24-bit AES3 in HD (20-bit in SD) |

| Specification                        | Value                                    |
|--------------------------------------|--|
| Channels                             | 1 Stereo Pair (2 channels)               |
| Output                               | AES                                      |
| File Format                          | Multi-channel Waveform Audio File (.wav) |
| Impedance                            | 110 Ohms, differential                   |
| Minimum/Maximum output voltage swing | 1.5/6V peak-to-peak                      |
| Rise and Fall Times                  | 20ns, typical                            |
| Sample Rate                          | 48kHz                                    |
| Synchronization                      | Locked to Video                          |

## Jitter

| Specification            | Value   |
|--------------------------|---|
| HD - Tri-Level Sync      | Alignment (> 100kHz) < 0.2UI                        |
|                          | Timing (<10Hz) < 1.0UI                              |
| HD - Composite Reference | Performance not guaranteed with composite reference |
| SD - Tri-Level Sync      | Alignment (> 1kHz) < 0.2UI                          |
|                          | Timing (<10Hz) < 0.2UI                              |
| SD - Composite Reference | Alignment (> 1kHz) < 0.2UI                          |
|                          | Timing (<10Hz) < 0.5UI                              |

## System Timing

- All video inputs zero time relative to reference input, auto timing will correct for inputs out of time by up to +/- 0.25 line.
- System delay is less than 1 line.

## Network Ports

The following network ports are used:

- Dashboard Master — 5253
- Dashboard Sat 1 — 5255
- Dashboard Sat 2 — 5256
- Dashboard SoftPanel — 5257
- FTP — 21
- NTP — 123
- RossTalk — 7788
- SLP — 427
- SSH — 22
- TFTP — 69
- TSL — 5727
- Web Server 1 — 80

## Power Consumption

|               | Carbonite Black                   | Carbonite Black+  | Carbonite Black+ 12G |
|---------------|-----------------------------------|-------------------|----------------------|
| Consumption   | 120W 2.5A<br>48V                  | 180W 3.75A<br>48V | 206W 4.3A<br>48V     |
| Input Voltage | 100 - 120V~, 220 - 240V~, 47-63Hz |                   |                      |

## Ports

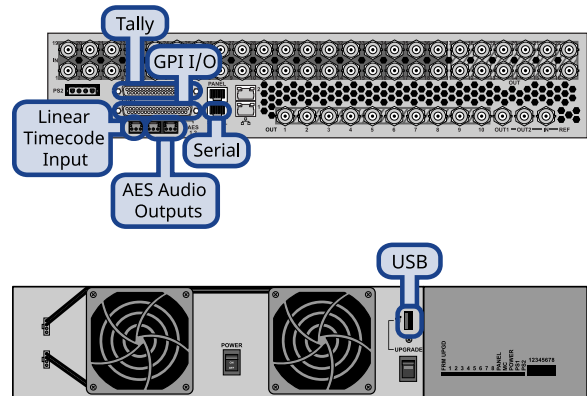

## Serial Port

The serial port supports the RS-422 transmission standard in the following format:

- 38.4k Baud
- 8 bits
- 1 stop bit
- Odd Parity

**Table 7: Serial Port Pinouts**

| Pin | Signal |
|-----|--------|
| 1   | Tx+    |
| 2   | Tx-    |
| 3   | Rx+    |
| 4   | n/c    |
| 5   | n/c    |
| 6   | Rx-    |
| 7   | Ground |
| 8   | Ground |

## GPI Port

The switcher supports 34 GPI I/Os.

**Table 8: GPI I/O Pinouts**

| Pin | Signal     |
|-----|------------|
| 1   | GPI I/O 1  |
| 2   | GPI I/O 2  |
| 3   | GPI I/O 3  |
| 4   | GPI I/O 4  |
| 5   | GPI I/O 5  |
| 6   | GPI I/O 6  |
| 7   | GPI I/O 7  |
| 8   | GPI I/O 8  |
| 9   | GPI I/O 9  |
| 10  | GPI I/O 10 |
| 11  | GPI I/O 11 |
| 12  | GPI I/O 12 |
| 13  | GPI I/O 13 |
| 14  | GPI I/O 14 |
| 15  | GPI I/O 15 |
| 16  | GPI I/O 16 |
| 17  | GPI I/O 17 |
| 18  | GPI I/O 18 |
| 19  | GPI I/O 19 |
| 20  | GPI I/O 20 |
| 21  | GPI I/O 21 |
| 22  | GPI I/O 22 |
| 23  | GPI I/O 23 |
| 24  | GPI I/O 24 |
| 25  | Ground     |
| 26  | GPI I/O 25 |
| 27  | GPI I/O 26 |
| 28  | GPI I/O 27 |
| 29  | GPI I/O 28 |
| 30  | GPI I/O 29 |
| 31  | Ground     |
| 32  | GPI I/O 30 |
| 33  | GPI I/O 31 |
| 34  | GPI I/O 32 |
| 35  | GPI I/O 33 |
| 36  | GPI I/O 34 |
| 37  | n/c        |

## Tally Port

The switcher supports 34 fixed tallies.

**Table 9: Tally Rating**

| Specification   | Value            |
|-----------------|------------------|
| Input Voltage   | 24VAC(rms)/40VDC |
| Maximum Current | 120mA            |
| Impedance       | <15 ohm          |

**Note:** The tally pin must be connected to the proper common to complete the circuit. For example, tally 6 on pin 7 must be connected to the common on pin 31.

**Table 10: Tally Pinouts**

| Pin | Tally #                    |
|-----|----------------------------|
| 1   | Common (pins 2-6, 20-25)   |
| 2   | 1                          |
| 3   | 2                          |
| 4   | 3                          |
| 5   | 4                          |
| 6   | 5                          |
| 7   | 6                          |
| 8   | 7                          |
| 9   | 8                          |
| 10  | 9                          |
| 11  | 10                         |
| 12  | 11                         |
| 13  | 12                         |
| 14  | 13                         |
| 15  | 14                         |
| 16  | 15                         |
| 17  | 16                         |
| 18  | 17                         |
| 19  | Common (pins 13-18, 32-37) |
| 20  | 18                         |
| 21  | 19                         |
| 22  | 20                         |
| 23  | 21                         |
| 24  | 22                         |
| 25  | 23                         |
| 26  | 24                         |
| 27  | 25                         |

| Pin | Tally #                   |
|-----|---------------------------|
| 28  | 26                        |
| 29  | 27                        |
| 30  | 28                        |
| 31  | Common (pins 7-12, 26-30) |
| 32  | 29                        |
| 33  | 30                        |
| 34  | 31                        |
| 35  | 32                        |
| 36  | 33                        |
| 37  | 34                        |

### AES Port

The AES ports on the back of the frame each support a single 24-bit (20-bit in SD) stereo pair.

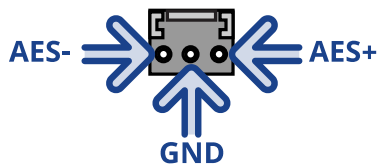

### LTC Port

The LTC port on the back of the frame supports a single LTC connection.

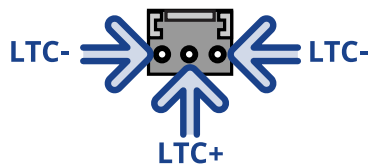

### USB Port

The USB port is located at the front of the frame and is primarily intended for upgrades and storing media items and switcher sets.

**Connector** — USB 2.0, Type-A, 10 W (5 V @ 2 A)

# Custom Control Events

The Custom Control editor in DashBoard allows you to add or edit events in custom controls.

| Event                  | Location                                | Description   |
|------------------------|---|---|
| Ancillary Data Mode    | Switcher Installation > Ancillary Mode  | Select how the switcher will strip or pass ancillary data.<br><ol style="list-style-type: none"> <li>1. Click a <b>Value</b> button to select how the switcher treats ancillary data.</li> </ol>  |
| Audio Mixer Pan        | Devices > Audio Mixer                   | Set the pan level for the selected channel on the selected device.<br><ol style="list-style-type: none"> <li>1. Click <b>Audio Pan</b>.</li> <li>2. Click the <b>Audio Mixer</b> button and select the device you want to send the command to.</li> <li>3. Click the <b>Channel</b> button and select the channel you want to send the command to.</li> <li>4. Click the <b>Change Type</b> button and select whether you want to set (<b>Absolute</b>) or reset (<b>Reset</b>) the parameter. Some selections will not be available when you reset the parameter.</li> <li>5. Enter the new pan level in the <b>Pan Left/Right (%)</b> field.</li> </ol> |
| Audio Mixer Volume     | Devices > Audio Mixer                   | Set the level for the selected channel on the selected device.<br><ol style="list-style-type: none"> <li>1. Click <b>Audio Volume</b>.</li> <li>2. Click the <b>Audio Mixer</b> button and select the device you want to send the command to.</li> <li>3. Click the <b>Channel</b> button and select the channel you want to send the command to.</li> <li>4. Click the <b>Change Type</b> button and select whether you want to set (<b>Absolute</b>) or reset (<b>Reset</b>) the parameter. Some selections will not be available when you reset the parameter.</li> <li>5. Enter the new audio level in the <b>Volume (%)</b> field.</li> </ol>        |
| Auto Trans             | Switcher > Transition > ME Trans Action | Performs an auto transition on the selected area.<br><ol style="list-style-type: none"> <li>1. Click the <b>ME</b> button and select the area that you want to perform the event on.</li> <li>2. Click the <b>Action</b> button and select <b>Auto Trans</b>.</li> </ol>  |
| Bus Source Select      | Switcher > Bus Source Select            | Select a source on the selected bus for the selected area.<br><ol style="list-style-type: none"> <li>1. Click the <b>ME</b> button and select the area that you want to select a bus on.</li> <li>2. Click the <b>Bus/Keyer</b> button and select the bus that you want to select a source on.</li> <li>3. If you selected a key bus, click a <b>Bus</b> button to select whether you are selecting a source for the fill (<b>Video</b>) or the alpha (<b>Alpha</b>) of the key.</li> <li>4. Click the <b>Source</b> button and select the source that you want on the selected bus.</li> </ol>   |
| Cancel All CC          | Special > Cancel All                    | Cancel all running custom controls.   |
| Cancel CC              | Special > Cancel CC                     | Cancel a running custom control.<br><ol style="list-style-type: none"> <li>1. Click the <b>Bank</b> button and select the custom control bank you want to cancel a custom control on.</li> <li>2. Click the <b>CC</b> button and select the custom control you want to cancel.</li> </ol>   |
| Chroma Key, Initialize | Switcher > Keyer > Chroma Keyer Init    | Initialize a chroma key for the selected key for the selected area.<br><ol style="list-style-type: none"> <li>1. Click the <b>ME</b> button and select the area that you want to perform the event on.</li> <li>2. Click the <b>Keyer</b> button for the key you want to perform the event on.</li> </ol>   |



| Event                   | Location   | Description   |
|-------------------------|--|---|
| <b>Chroma Key Color</b> | <b>Switcher &gt; Keyer &gt; Chroma Keyer Color</b>             | Select the color you want to key out for the selected key for the selected area.<br><ol style="list-style-type: none"> <li>1. Click the <b>ME</b> button and select the area that you want to perform the event on.</li> <li>2. Click the <b>Keyer</b> button for the key you want to perform the event on.</li> <li>3. Click <b>Color</b> and select the color you want to key out.</li> </ol>   |
| <b>Chroma Key Mode</b>  | <b>Switcher &gt; Keyer &gt; Chroma Keyer Mode</b>              | Select the mode for a chroma key for the selected key for the selected area.<br><ol style="list-style-type: none"> <li>1. Click the <b>ME</b> button and select the area that you want to perform the event on.</li> <li>2. Click the <b>Keyer</b> button for the key you want to perform the event on.</li> <li>3. Click a <b>Mode</b> button to select whether you want the chroma key to operate in basic mode (<b>Basic</b>), or advanced (<b>Advanced</b>).</li> </ol>   |
| <b>Chroma Key Setup</b> | <b>Switcher &gt; Keyer &gt; Chroma Keyer Param</b>             | Select the various advanced chroma key settings for the selected key for the selected area.<br><ol style="list-style-type: none"> <li>1. Click the <b>ME</b> button and select the area that you want to perform the event on.</li> <li>2. Click the <b>Keyer</b> button for the key you want to perform the event on.</li> <li>3. Click the <b>Parameter</b> button and select the parameter you want to adjust.</li> <li>4. Click the <b>Value</b> button and select the new value you want to enter for the selected parameter.</li> </ol>   |
| <b>Clean Feed</b>       | <b>Switcher Installation &gt; ME &gt; ME Clean Feed</b>        | Select the clean feed location for the selected ME.<br><ol style="list-style-type: none"> <li>1. Click the <b>ME</b> button for the ME that you want to perform the event on.</li> <li>2. Click a <b>Before Keyer</b> button to select whether you want the clean feed output to be taken before key 1 (<b>Keyer 1</b>), key 2 (<b>Keyer 2</b>), or key 3 (<b>Keyer 3</b>).</li> </ol>  |
| <b>Color Framing</b>    | <b>Switcher Installation &gt; Reference &gt; Color Framing</b> | Select whether color framing for the reference outputs is synchronized.<br><ol style="list-style-type: none"> <li>1. Click a <b>Framing</b> button to select whether color framing is synchronized (<b>Sync</b>) or not (<b>NoSync</b>).</li> </ol>   |
| <b>Cut</b>              | <b>Switcher &gt; Transition &gt; ME Trans Action</b>           | Performs a cut on the selected ME.<br><ol style="list-style-type: none"> <li>1. Click the <b>ME</b> button and select the area that you want to perform the event on.</li> <li>2. Click the <b>Action</b> button and select <b>Cut</b>.</li> </ol>  |
| <b>DVE Freeze</b>       | <b>Switcher &gt; Keyer &gt; DVE Freeze</b>                     | Turn the DVE freeze feature on or off for the selected key for the selected ME, MiniME™, or MultiScreen.<br><ol style="list-style-type: none"> <li>1. Click the <b>ME</b> button and select the area that you want to perform the event on.</li> <li>2. Click the <b>Keyer</b> button for the key you want to perform the event on.</li> <li>3. Click the <b>Change Type</b> button and select whether you want to set (<b>Absolute</b>) or reset (<b>Reset</b>) the parameter. Some selections will not be available when you reset the parameter.</li> <li>4. Click the <b>Value</b> button and select whether to freeze the video and appearance of a key (<b>On</b>) or not (<b>Off</b>). When a key is frozen, the DVE attribute are disabled and you can not move the key.</li> </ol> |

| Event                         | Location                                     | Description  |
|-------------------------------|--|--|
| DVE Key Aspect                | Switcher > Keyer > DVE Param                 | <p>Select the aspect ratio for the DVE key on the selected key for the selected ME.</p> <ol style="list-style-type: none"> <li>1. Click the <b>ME</b> button for the ME that you want to perform the event on.</li> <li>2. Click the <b>Keyer</b> button for the key you want to perform the event on.</li> <li>3. Click the <b>Parameter</b> button and select <b>Aspect</b>.</li> <li>4. Click the <b>Change Type</b> button and select whether you want to set (<b>Absolute</b>) or reset (<b>Reset</b>) the parameter. Some selections will not be available when you reset the parameter.</li> <li>5. Enter an aspect ratio in the <b>Value (%)</b> field.</li> </ol>   |
| DVE Key Border Color (HSL)    | Switcher > Keyer > DVE Border Color (HSL)    | <p>Select the custom color you want to apply to the border of the DVE key of the selected area. Each component of the HSL color must be inserted individually.</p> <ol style="list-style-type: none"> <li>1. Click the <b>ME</b> button and select the area that you want to perform the event on.</li> <li>2. Click the <b>Keyer</b> button for the key you want to perform the event on.</li> <li>3. Click the <b>Change Type</b> button and select whether you want to set (<b>Absolute</b>) or reset (<b>Reset</b>) the parameter. Some selections will not be available when you reset the parameter.</li> <li>4. Click the <b>Component</b> button and select the HSL component you want to assign a value to. A value should be applied to all three components.</li> <li>5. Enter a value for the selected component in the <b>Value (%)</b> field.</li> </ol> |
| DVE Key Border Color (Preset) | Switcher > Keyer > DVE Border Color (Preset) | <p>Select the preset color you want to apply to the border of the DVE key of the selected key for the selected area.</p> <ol style="list-style-type: none"> <li>1. Click the <b>ME</b> button and select the area that you want to perform the event on.</li> <li>2. Click the <b>Keyer</b> button for the key you want to perform the event on.</li> <li>3. Click the <b>Color</b> button and select the preset color you want to apply to the border.</li> </ol>   |
| DVE Key Border                | Switcher > Keyer > DVE Param                 | <p>Select the size of border for the DVE key on the selected key for the selected ME.</p> <ol style="list-style-type: none"> <li>1. Click the <b>ME</b> button for the ME that you want to perform the event on.</li> <li>2. Click the <b>Keyer</b> button for the key you want to perform the event on.</li> <li>3. Click the <b>Parameter</b> button and select <b>Border</b>.</li> <li>4. Click the <b>Change Type</b> button and select whether you want to set (<b>Absolute</b>) or reset (<b>Reset</b>) the parameter. Some selections will not be available when you reset the parameter.</li> <li>5. Enter a size for the border in the <b>Value (%)</b> field.</li> </ol>   |

| Event                             | Location                                       | Description   |
|-----------------------------------|--|---|
| <b>DVE Key Crop (Bottom Edge)</b> | <b>Switcher &gt; Keyer &gt; DVE Param</b>      | <p>Select the amount of cropping on the bottom edge of the DVE key on the selected key for the selected ME.</p> <ol style="list-style-type: none"> <li>1. Click the <b>ME</b> button for the ME that you want to perform the event on.</li> <li>2. Click the <b>Keyer</b> button for the key you want to perform the event on.</li> <li>3. Click the <b>Parameter</b> button and select <b>Bottom Edge</b>.</li> <li>4. Click the <b>Change Type</b> button and select whether you want to set (<b>Absolute</b>) or reset (<b>Reset</b>) the parameter. Some selections will not be available when you reset the parameter.</li> <li>5. Enter the amount of cropping in the <b>Value (%)</b> field.</li> </ol>  |
| <b>DVE Key Crop (Dual Edge)</b>   | <b>Switcher &gt; Keyer &gt; DVE Crop Param</b> | <p>Select the amount of cropping on both horizontal or vertical edges of the DVE key of the selected key for the selected area.</p> <ol style="list-style-type: none"> <li>1. Click the <b>ME</b> button and select the area that you want to perform the event on.</li> <li>2. Click the <b>Keyer</b> button for the key you want to perform the event on.</li> <li>3. Click the <b>Change Type</b> button and select whether you want to set (<b>Absolute</b>) or reset (<b>Reset</b>) the parameter. Some selections will not be available when you reset the parameter.</li> <li>4. Click the <b>Parameter</b> button and select the edges you want to crop.</li> <li>5. Enter the amount of Left or Top cropping you want to apply in the <b>Value %</b> field.</li> <li>6. Enter the amount of Right or Bottom cropping you want to apply in the <b>Other Value %</b> field.</li> </ol> |
| <b>DVE Key Crop (Left Edge)</b>   | <b>Switcher &gt; Keyer &gt; DVE Param</b>      | <p>Select the amount of cropping on the left edge of the DVE key on the selected key for the selected ME.</p> <ol style="list-style-type: none"> <li>1. Click the <b>ME</b> button for the ME that you want to perform the event on.</li> <li>2. Click the <b>Keyer</b> button for the key you want to perform the event on.</li> <li>3. Click the <b>Parameter</b> button and select <b>Left Edge</b>.</li> <li>4. Click the <b>Change Type</b> button and select whether you want to set (<b>Absolute</b>) or reset (<b>Reset</b>) the parameter. Some selections will not be available when you reset the parameter.</li> <li>5. Enter the amount of cropping in the <b>Value (%)</b> field.</li> </ol>  |
| <b>DVE Key Crop (Right Edge)</b>  | <b>Switcher &gt; Keyer &gt; DVE Param</b>      | <p>Select the amount of cropping on the right edge of the DVE key on the selected key for the selected ME.</p> <ol style="list-style-type: none"> <li>1. Click the <b>ME</b> button for the ME that you want to perform the event on.</li> <li>2. Click the <b>Keyer</b> button for the key you want to perform the event on.</li> <li>3. Click the <b>Parameter</b> button and select <b>Right Edge</b>.</li> <li>4. Click the <b>Change Type</b> button and select whether you want to set (<b>Absolute</b>) or reset (<b>Reset</b>) the parameter. Some selections will not be available when you reset the parameter.</li> <li>5. Enter the amount of cropping in the <b>Value (%)</b> field.</li> </ol>  |

| Event                          | Location                                  | Description  |
|--------------------------------|---|--|
| <b>DVE Key Crop (Top Edge)</b> | <b>Switcher &gt; Keyer &gt; DVE Param</b> | <p>Select the amount of cropping on the top edge of the DVE key on the selected key for the selected ME.</p> <ol style="list-style-type: none"> <li>1. Click the <b>ME</b> button for the ME that you want to perform the event on.</li> <li>2. Click the <b>Keyer</b> button for the key you want to perform the event on.</li> <li>3. Click the <b>Parameter</b> button and select <b>Top Edge</b>.</li> <li>4. Click the <b>Change Type</b> button and select whether you want to set (<b>Absolute</b>) or reset (<b>Reset</b>) the parameter. Some selections will not be available when you reset the parameter.</li> <li>5. Enter the amount of cropping in the <b>Value (%)</b> field.</li> </ol>                               |
| <b>DVE Key Edge Softness</b>   | <b>Switcher &gt; Keyer &gt; DVE Param</b> | <p>Select the amount of softness to apply to the edge of the DVE key on the selected key for the selected ME.</p> <ol style="list-style-type: none"> <li>1. Click the <b>ME</b> button for the ME that you want to perform the event on.</li> <li>2. Click the <b>Keyer</b> button for the key you want to perform the event on.</li> <li>3. Click the <b>Parameter</b> button and select <b>Softness</b>.</li> <li>4. Click the <b>Change Type</b> button and select whether you want to set (<b>Absolute</b>) or reset (<b>Reset</b>) the parameter. Some selections will not be available when you reset the parameter.</li> <li>5. Enter an amount of softness for the DVE key or border in the <b>Value (%)</b> field.</li> </ol> |
| <b>DVE Key Size</b>            | <b>Switcher &gt; Keyer &gt; DVE Param</b> | <p>Select the size of the DVE key on the selected key for the selected ME.</p> <ol style="list-style-type: none"> <li>1. Click the <b>ME</b> button for the ME that you want to perform the event on.</li> <li>2. Click the <b>Keyer</b> button for the key you want to perform the event on.</li> <li>3. Click the <b>Parameter</b> button and select <b>Size</b>.</li> <li>4. Click the <b>Change Type</b> button and select whether you want to set (<b>Absolute</b>) or reset (<b>Reset</b>) the parameter. Some selections will not be available when you reset the parameter.</li> <li>5. Enter a new size in the <b>Value (%)</b> field.</li> </ol>   |
| <b>DVE Key X-Position</b>      | <b>Switcher &gt; Keyer &gt; DVE Param</b> | <p>Select the x-axis position of the DVE key on the selected key for the selected ME.</p> <ol style="list-style-type: none"> <li>1. Click the <b>ME</b> button for the ME that you want to perform the event on.</li> <li>2. Click the <b>Keyer</b> button for the key you want to perform the event on.</li> <li>3. Click the <b>Parameter</b> button and select <b>X-Pos</b>.</li> <li>4. Click the <b>Change Type</b> button and select whether you want to set (<b>Absolute</b>) or reset (<b>Reset</b>) the parameter. Some selections will not be available when you reset the parameter.</li> <li>5. Enter a new position in the <b>Value (%)</b> field.</li> </ol>   |

| Event                          | Location  | Description   |
|--------------------------------|---|---|
| DVE Key Y-Position             | Switcher > Keyer > DVE Param                      | <p>Select the y-axis position for the DVE key on the selected key for the selected ME.</p> <ol style="list-style-type: none"> <li>1. Click the <b>ME</b> button for the ME that you want to perform the event on.</li> <li>2. Click the <b>Keyer</b> button for the key you want to perform the event on.</li> <li>3. Click the <b>Parameter</b> button and select <b>Y-Pos</b>.</li> <li>4. Click the <b>Change Type</b> button and select whether you want to set (<b>Absolute</b>) or reset (<b>Reset</b>) the parameter. Some selections will not be available when you reset the parameter.</li> <li>5. Enter a new position in the <b>Value (%)</b> field.</li> </ol> |
| DVE Wipe, Reset                | Switcher > Transition > DVE Wipe Reset            | <p>Reset the parameters or direction and flip-flop for the DVE wipe transition of the selected ME.</p> <ol style="list-style-type: none"> <li>1. Click the <b>ME</b> button for the ME that you want to perform the event on.</li> <li>2. Click <b>Reset</b> to reset the DVE wipe parameters.</li> </ol>   |
| DVE Wipe Direction (Flip-Flop) | Switcher > Transition > DVE Wipe Direction        | <p>Select whether the DVE wipe reverses direction for every second transition of the selected ME.</p> <ol style="list-style-type: none"> <li>1. Click the <b>ME</b> button for the ME that you want to perform the event on.</li> <li>2. Click the <b>Change Type</b> button and select whether you want to set (<b>Absolute</b>) or reset (<b>Reset</b>) the parameter. Some selections will not be available when you reset the parameter.</li> <li>3. Click <b>Flip-Flip</b>.</li> <li>4. Click <b>On</b> or <b>Off</b> to select whether Flip-Flop is on (<b>On</b>) or not (<b>Off</b>).</li> </ol>  |
| DVE Wipe Direction             | Switcher > Transition > DVE Wipe Direction        | <p>Select the direction for the DVE wipe transition of the selected ME.</p> <ol style="list-style-type: none"> <li>1. Click the <b>ME</b> button for the ME that you want to perform the event on.</li> <li>2. Click the <b>Change Type</b> button and select whether you want to set (<b>Absolute</b>) or reset (<b>Reset</b>) the parameter. Some selections will not be available when you reset the parameter.</li> <li>3. Click <b>Direction</b>.</li> <li>4. Click <b>Forward</b> or <b>Reverse</b> to select whether the DVE wipe moves in a forward (<b>Forward</b>) or reverse (<b>Reverse</b>) direction.</li> </ol>  |
| DVE Wipe Pattern               | Switcher > Transition > DVE Wipe Effect           | <p>Select the pattern you want to use for a DVE wipe transition of the selected ME.</p> <ol style="list-style-type: none"> <li>1. Click the <b>ME</b> button for the ME that you want to perform the event on.</li> <li>2. Click the <b>Effect</b> button and select the pattern you want to use for the DVE wipe.</li> </ol>   |
| EmbeddedTriggers — Enable      | Switcher Installation > Embedded Trigger > Enable | <p>Select whether EmbeddedTriggers is enabled or not for the selected output.</p> <ol style="list-style-type: none"> <li>1. Click the <b>Output</b> button and select the output BNC that you want to send EmbeddedTriggers commands on.</li> <li>2. Click the <b>Change Type</b> button and select whether you want to set (<b>Absolute</b>) or reset (<b>Reset</b>) the parameter. Some selections will not be available when you reset the parameter.</li> <li>3. Click a <b>Value</b> button to select whether EmbeddedTriggers commands are inserted for the selected output (<b>On</b>) or not (<b>Off</b>).</li> </ol>   |

| Event                             | Location  | Description   |
|-----------------------------------|---|---|
| EmbeddedTriggers — Insert Trigger | Switcher Installation > Embedded Trigger > Trigger CC | Select the custom control to insert into the EmbeddedTriggers message.<br><ol style="list-style-type: none"> <li>1. Enter the custom control bank in the <b>Bank</b> field.</li> <li>2. Enter the custom control in the <b>CC</b> field.</li> </ol>   |
| EmbeddedTriggers — Set DID        | Switcher Installation > Embedded Trigger > Settings   | Select the data identifier word (DID) you want to use for the EmbeddedTriggers message.<br><ol style="list-style-type: none"> <li>1. Click <b>DID</b></li> <li>2. Click the <b>Change Type</b> button and select whether you want to set (<b>Absolute</b>) or reset (<b>Reset</b>) the parameter. Some selections will not be available when you reset the parameter.</li> <li>3. Enter the DID value you want to use in the <b>Value</b> field.</li> </ol>   |
| EmbeddedTriggers — Set Line       | Switcher Installation > Embedded Trigger > Settings   | Select the line in the VANC that the EmbeddedTriggers message will be inserted on.<br><ol style="list-style-type: none"> <li>1. Click <b>Line</b></li> <li>2. Click the <b>Change Type</b> button and select whether you want to set (<b>Absolute</b>) or reset (<b>Reset</b>) the parameter. Some selections will not be available when you reset the parameter.</li> <li>3. Enter the line value you want to use in the <b>Value</b> field.</li> </ol>  |
| EmbeddedTriggers — Set Remote ID  | Switcher Installation > Embedded Trigger > Settings   | Select the remote ID you want to use to identify the switcher that the EmbeddedTriggers message is coming from.<br><ol style="list-style-type: none"> <li>1. Click <b>Remote ID</b></li> <li>2. Click the <b>Change Type</b> button and select whether you want to set (<b>Absolute</b>) or reset (<b>Reset</b>) the parameter. Some selections will not be available when you reset the parameter.</li> <li>3. Enter the remote ID value you want to use in the <b>Value</b> field.</li> </ol>   |
| EmbeddedTriggers — Set SDID       | Switcher Installation > Embedded Trigger > Settings   | Select the secondary data identifier word (SDID) you want to use for the EmbeddedTriggers message.<br><ol style="list-style-type: none"> <li>1. Click <b>SDID</b></li> <li>2. Click the <b>Change Type</b> button and select whether you want to set (<b>Absolute</b>) or reset (<b>Reset</b>) the parameter. Some selections will not be available when you reset the parameter.</li> <li>3. Enter the SDID value you want to use in the <b>Value</b> field.</li> </ol>  |
| Fly Key (DVE)                     | Switcher > Keyer > Keyer Fly                          | Assign DVE resources (Fly) to the selected key for the selected area.<br><ol style="list-style-type: none"> <li>1. Click the <b>ME</b> button and select the area that you want to perform the event on.</li> <li>2. Click the <b>Keyer</b> button for the key you want to perform the event on.</li> <li>3. Click the <b>Change Type</b> button and select whether you want to set (<b>Absolute</b>) or reset (<b>Reset</b>) the parameter. Some selections will not be available when you reset the parameter.</li> <li>4. Click the <b>Value</b> button and select whether DVE resources are assigned to the key (<b>On</b>) or not (<b>Off</b>).</li> </ol> |
| GPI Output — Edge Trigger Setup   | Devices > GPO   | Set up the type of edge trigger for the GPI output.<br><ol style="list-style-type: none"> <li>1. Click <b>GPO Edge Duration</b></li> <li>2. Click the <b>GPO</b> button and select the GPI output that you want to configure.</li> <li>3. Click the <b>Change Type</b> button and select whether you want to set (<b>Absolute</b>) or reset (<b>Reset</b>) the parameter. Some selections will not be available when you reset the parameter.</li> <li>4. Enter the duration of the edge trigger in the <b>Duration (fr)</b> field.</li> </ol>  |

| Event                            | Location                             | Description  |
|----------------------------------|--------------------------------------|--|
| GPI Output — Level Trigger Setup | Devices > GPO                        | Set up the type of level trigger for the GPI output. <ol style="list-style-type: none"> <li>1. Click <b>GPO Level Config</b></li> <li>2. Click the <b>GPO</b> button and select the GPI output that you want to configure.</li> <li>3. Click a <b>Level</b> to select whether the level trigger uses a high (<b>High</b>) or low (<b>Low</b>) level trigger.</li> </ol>  |
| GPI Output — Mode                | Devices > GPO                        | Select whether the level trigger GPI output act as a tally. <ol style="list-style-type: none"> <li>1. Click <b>GPO Mode</b></li> <li>2. Click the <b>GPO</b> button and select the GPI output that you want to configure.</li> <li>3. Click a <b>Mode</b> button to select whether the level trigger GPI output, when assigned to video source, acts as a roll clip (<b>Normal</b>) or as a tally (<b>Tally</b>) for the selected source.</li> </ol>   |
| GPI Output — Trigger             | Devices > GPO                        | Trigger a GPI output. <ol style="list-style-type: none"> <li>1. Click <b>GPO Trigger</b></li> <li>2. Click the <b>GPO</b> button and select the GPI output that you want to trigger.</li> </ol>  |
| GPI Output — Trigger Type        | Devices > GPO                        | Select the type of trigger for the GPI output. <ol style="list-style-type: none"> <li>1. Click <b>GPO Trigger Configuration</b></li> <li>2. Click the <b>GPO</b> button and select the GPI output that you want to configure.</li> <li>3. Click a <b>Trigger</b> to select whether the GPI output uses a level (<b>Level</b>) or edge (<b>Edge</b>) trigger.</li> </ol>  |
| Hold CC                          | Special > Hold                       | Insert a hold into the custom control.   |
| Key, Make Linear                 | Switcher > Keyer > Keyer Make Linear | Make the selected key linear on the selected area. <ol style="list-style-type: none"> <li>1. Click the <b>ME</b> button and select the area that you want to perform the event on.</li> <li>2. Click the <b>Keyer</b> button for the key you want to make linear.</li> </ol>   |
| Key Active                       | Switcher > Keyer > Keyer Active      | Transition a key (or include it in the next transition) on or off-air for the selected area. <ol style="list-style-type: none"> <li>1. Click the <b>ME</b> button and select the area that you want to perform the event on.</li> <li>2. Click the <b>Keyer</b> button for the key you want to perform the event on.</li> <li>3. Click the <b>Change Type</b> button and select whether you want to set (<b>Absolute</b>) or reset (<b>Reset</b>) the parameter. Some selections will not be available when you reset the parameter.</li> <li>4. Click the <b>Parameter</b> button and select a cut (<b>Cut Key</b>) or auto transition (<b>Trans Key</b>) for the key, or have to key included in the next transition (<b>Include Key</b>).</li> <li>5. Click the <b>Value</b> button to select whether the key is transitioned on-air / included in the next transition to go on-air (<b>On</b>) or off-air / included in the next transition to go off-air (<b>Off</b>).</li> </ol> |



| Event                                   | Location                              | Description  |
|---|---------------------------------------|--|
| Key Copy                                | Switcher > Keyer > Keyer Copy         | <p>Copy the contents of one key to another key the same or a different area.</p> <ol style="list-style-type: none"> <li>1. Click the <b>Target ME</b> button and select where you want to copy the key to.</li> <li>2. Click the <b>Target Keyer</b> button for the key you want to copy to.</li> <li>3. Click the <b>Source ME</b> button and select where you want to copy the key from.</li> <li>4. Click the <b>Source Keyer</b> button for the key you want to copy from.</li> </ol>  |
| Key Invert                              | Switcher > Keyer > Keyer Invert       | <p>Turn the key invert feature on or off for the selected key for the selected area.</p> <ol style="list-style-type: none"> <li>1. Click the <b>ME</b> button and select the area that you want to perform the event on.</li> <li>2. Click the <b>Keyer</b> button for the key you want to reverse the polarity of the key alpha so that the holes in the background are cut by dark areas of the key alpha instead of bright areas.</li> <li>3. Click the <b>Change Type</b> button and select whether you want to set (<b>Absolute</b>) or reset (<b>Reset</b>) the parameter. Some selections will not be available when you reset the parameter.</li> <li>4. Click a <b>Value</b> button to turn key invert on (<b>On</b>) or off (<b>Off</b>).</li> </ol> |
| Key Mode                                | Switcher > Keyer > Keyer Mode         | <p>Select the mode for the selected key for the selected area.</p> <ol style="list-style-type: none"> <li>1. Click the <b>ME</b> button and select the area that you want to perform the event on.</li> <li>2. Click the <b>Keyer</b> button for the key you want to perform the event on.</li> <li>3. Click a <b>Mode</b> button to have the key set as shaped/unshaped from the key (<b>Normal</b>), as additive for a shaped source (<b>Additive</b>), or alpha to fully opaque/white (<b>Full</b>).</li> </ol>   |
| Key Only Transition                     | Switcher > Keyer > Keyer Trans        | <p>Perform a key only transition for the selected area.</p> <ol style="list-style-type: none"> <li>1. Click the <b>ME</b> button and select the area that you want to perform the event on.</li> <li>2. Click the <b>Keyer</b> button for the key you want to perform the event on.</li> <li>3. Click the <b>Action</b> button and select whether they key should perform a cut (<b>Cut</b>), or auto transition (<b>Auto Trans</b>).</li> </ol>   |
| Key Reset                               | Switcher > Keyer > Keyer Reset Params | <p>Reset the parameters for the selected key for the selected area.</p> <ol style="list-style-type: none"> <li>1. Click the <b>ME</b> button and select the area that you want to perform the event on.</li> <li>2. Click the <b>Keyer</b> button for the key you want to reset the clip, gain, transparency, invert, and mask for.</li> </ol>   |
| Key Settings (Clip, Gain, Transparency) | Switcher > Keyer > Keyer Settings     | <p>Select clip, gain, and transparency settings for the selected key for the selected area.</p> <ol style="list-style-type: none"> <li>1. Click the <b>ME</b> button and select the area that you want to perform the event on.</li> <li>2. Click the <b>Keyer</b> button for the key you want to perform the event on.</li> <li>3. Click the <b>Change Type</b> button and select whether you want to set (<b>Absolute</b>) or reset (<b>Reset</b>) the parameter. Some selections will not be available when you reset the parameter.</li> <li>4. Enter a value for the clip, gain, or transparency for the key in the <b>Value</b> field.</li> </ol>  |

| Event          | Location                                   | Description   |
|----------------|--|---|
| Key Swap       | Switcher > Keyer > Keyer Swap              | <p>Swap the contents of one key with another key the same or a different area.</p> <ol style="list-style-type: none"> <li>1. Click the <b>1st ME</b> button and select where the first key you want to swap is.</li> <li>2. Click the <b>1st Keyer</b> button for the first key you want to swap.</li> <li>3. Click the <b>2nd ME</b> button and select where the second key you want to swap is.</li> <li>4. Click the <b>2nd Keyer</b> button for the second key you want to swap.</li> </ol>   |
| Key Trans Rate | Switcher > Keyer > Keyer Trans Rate        | <p>Set or reset the keyer transition rate of the selected area.</p> <ol style="list-style-type: none"> <li>1. Click the <b>ME</b> button and select the area that you want to perform the event on.</li> <li>2. Click the <b>Keyer</b> button for the key you want to perform the event on.</li> <li>3. Click the <b>Change Type</b> button and select whether you want to set (<b>Absolute</b>) or reset (<b>Reset</b>) the parameter. Some selections will not be available when you reset the parameter.</li> <li>4. Enter a new transition rate, in frames, for the key in the <b>Value (fr)</b> field.</li> </ol>  |
| Key Type       | Switcher > Keyer > Keyer Type              | <p>Assign a key type for a key for the selected area.</p> <ol style="list-style-type: none"> <li>1. Click the <b>ME</b> button and select the area that you want to perform the event on.</li> <li>2. Click the <b>Keyer</b> button for the key you want to perform the event on.</li> <li>3. Click a <b>Type</b> button to assign the key type to the selected key.</li> </ol>   |
| Layer Mode     | Switcher Installation > ME > ME Layer Mode | <p>Select whether external layer mode is active for the selected ME.</p> <ol style="list-style-type: none"> <li>1. Click the <b>ME</b> button for the ME that you want to perform the event on.</li> <li>2. Click the <b>Change Type</b> button and select whether you want to set (<b>Absolute</b>) or reset (<b>Reset</b>) the parameter. Some selections will not be available when you reset the parameter.</li> <li>3. Click a <b>Value</b> button to select whether external layer mode is on (<b>On</b>) or not (<b>Off</b>).</li> </ol>   |
| Loop CC        | Special > Loop                             | <p>Insert a loop into the custom control.</p>   |
| Mask, Force    | Switcher > Keyer > Mask Force              | <p>Apply a mask to the selected key for the selected ME.</p> <ol style="list-style-type: none"> <li>1. Click the <b>ME</b> button for the ME that you want to perform the event on.</li> <li>2. Click the <b>Keyer</b> button for the key you want to perform the event on.</li> <li>3. Click the <b>Change Type</b> button and select whether you want to set (<b>Absolute</b>) or reset (<b>Reset</b>) the parameter. Some selections will not be available when you reset the parameter.</li> <li>4. Click the <b>Value</b> button and select whether to force the area inside the mask region to the foreground (<b>On</b>) or not (<b>Off</b>).</li> </ol> |

| Event   | Location                                       | Description   |
|---|--|---|
| <b>Mask, Invert</b>   | <b>Switcher &gt; Keyer &gt; Mask Invert</b>    | <p>Invert the mask of the selected key for the selected ME.</p> <ol style="list-style-type: none"> <li>1. Click the <b>ME</b> button for the ME that you want to perform the event on.</li> <li>2. Click the <b>Keyer</b> button for the key you want to perform the event on.</li> <li>3. Click the <b>Change Type</b> button and select whether you want to set (<b>Absolute</b>) or reset (<b>Reset</b>) the parameter. Some selections will not be available when you reset the parameter.</li> <li>4. Click the <b>Value</b> button and select whether to invert the masked area with the unmasked area (<b>On</b>) or not (<b>Off</b>).</li> </ol>  |
| <b>Mask, Reset</b>  | <b>Switcher &gt; Keyer &gt; Mask Reset</b>     | <p>Reset the mask of the selected key for the selected ME.</p> <ol style="list-style-type: none"> <li>1. Click the <b>ME</b> button for the ME that you want to perform the event on.</li> <li>2. Click the <b>Keyer</b> button for the key you want to perform the event on.</li> <li>3. Click the <b>Action</b> button and select the parameter you want to reset. <ul style="list-style-type: none"> <li>• <b>Reset Type</b> — turn mask off.</li> <li>• <b>Reset Forced</b> — turn force off.</li> <li>• <b>Reset Inverted</b> — turn invert off.</li> <li>• <b>Reset X-Pos</b> — reset horizontal position.</li> <li>• <b>Reset Y-Pos</b> — reset vertical position.</li> <li>• <b>Reset Size</b> — reset size.</li> <li>• <b>Reset Ver Edges</b> — reset top and bottom edges.</li> <li>• <b>Reset Hor Edges</b> — reset left and right edges.</li> </ul> </li> </ol> |
| <b>Mask (Box) — Bottom Edge Position</b><br>Mask (Box) — Bottom Edge Position | <b>Switcher &gt; Keyer &gt; Box Mask Param</b> | <p>Select the position for the bottom edge of the box mask on the selected key for the selected ME.</p> <ol style="list-style-type: none"> <li>1. Click the <b>ME</b> button for the ME that you want to perform the event on.</li> <li>2. Click the <b>Keyer</b> button for the key you want to perform the event on.</li> <li>3. Click the <b>Parameter</b> button and select <b>Bottom Edge</b>.</li> <li>4. Click the <b>Change Type</b> button and select whether you want to set (<b>Absolute</b>) or reset (<b>Reset</b>) the parameter. Some selections will not be available when you reset the parameter.</li> <li>5. Enter a new position in the <b>Value (%)</b> field.</li> </ol>  |
| <b>Mask (Box) — Left Edge Position</b>  | <b>Switcher &gt; Keyer &gt; Box Mask Param</b> | <p>Select the position for the left edge of the box mask on the selected key for the selected ME.</p> <ol style="list-style-type: none"> <li>1. Click the <b>ME</b> button for the ME that you want to perform the event on.</li> <li>2. Click the <b>Keyer</b> button for the key you want to perform the event on.</li> <li>3. Click the <b>Parameter</b> button and select <b>Left Edge</b>.</li> <li>4. Click the <b>Change Type</b> button and select whether you want to set (<b>Absolute</b>) or reset (<b>Reset</b>) the parameter. Some selections will not be available when you reset the parameter.</li> <li>5. Enter a new position in the <b>Value (%)</b> field.</li> </ol>  |

| Event                                   | Location                                       | Description  |
|---|--|--|
| <b>Mask (Box) — Right Edge Position</b> | <b>Switcher &gt; Keyer &gt; Box Mask Param</b> | <p>Select the position for the right edge of the box mask on the selected key for the selected ME.</p> <ol style="list-style-type: none"> <li>1. Click the <b>ME</b> button for the ME that you want to perform the event on.</li> <li>2. Click the <b>Keyer</b> button for the key you want to perform the event on.</li> <li>3. Click the <b>Parameter</b> button and select <b>Right Edge</b>.</li> <li>4. Click the <b>Change Type</b> button and select whether you want to set (<b>Absolute</b>) or reset (<b>Reset</b>) the parameter. Some selections will not be available when you reset the parameter.</li> <li>5. Enter a new position in the <b>Value (%)</b> field.</li> </ol> |
| <b>Mask (Box) — Size</b>                | <b>Switcher &gt; Keyer &gt; Box Mask Param</b> | <p>Select the size of the box mask on the selected key for the selected ME.</p> <ol style="list-style-type: none"> <li>1. Click the <b>ME</b> button for the ME that you want to perform the event on.</li> <li>2. Click the <b>Keyer</b> button for the key you want to perform the event on.</li> <li>3. Click the <b>Parameter</b> button and select <b>Size</b>.</li> <li>4. Click the <b>Change Type</b> button and select whether you want to set (<b>Absolute</b>) or reset (<b>Reset</b>) the parameter. Some selections will not be available when you reset the parameter.</li> <li>5. Enter a new size in the <b>Value (%)</b> field.</li> </ol>                                  |
| <b>Mask (Box) — Top Edge Position</b>   | <b>Switcher &gt; Keyer &gt; Box Mask Param</b> | <p>Select the position for the top edge of the box mask on the selected key for the selected ME.</p> <ol style="list-style-type: none"> <li>1. Click the <b>ME</b> button for the ME that you want to perform the event on.</li> <li>2. Click the <b>Keyer</b> button for the key you want to perform the event on.</li> <li>3. Click the <b>Parameter</b> button and select <b>Top Edge</b>.</li> <li>4. Click the <b>Change Type</b> button and select whether you want to set (<b>Absolute</b>) or reset (<b>Reset</b>) the parameter. Some selections will not be available when you reset the parameter.</li> <li>5. Enter a new position in the <b>Value (%)</b> field.</li> </ol>     |
| <b>Mask (Box) — X-Position</b>          | <b>Switcher &gt; Keyer &gt; Box Mask Param</b> | <p>Select the x-axis position of the box mask on the selected key for the selected ME.</p> <ol style="list-style-type: none"> <li>1. Click the <b>ME</b> button for the ME that you want to perform the event on.</li> <li>2. Click the <b>Keyer</b> button for the key you want to perform the event on.</li> <li>3. Click the <b>Parameter</b> button and select <b>X-Pos</b>.</li> <li>4. Click the <b>Change Type</b> button and select whether you want to set (<b>Absolute</b>) or reset (<b>Reset</b>) the parameter. Some selections will not be available when you reset the parameter.</li> <li>5. Enter a new position in the <b>Value (%)</b> field.</li> </ol>                  |

| Event                                      | Location                               | Description  |
|--|--|--|
| Mask (Box) — Y-Position                    | Switcher > Keyer > Box Mask Param      | <p>Select the y-axis position for the box mask on the selected key for the selected ME.</p> <ol style="list-style-type: none"> <li>1. Click the <b>ME</b> button for the ME that you want to perform the event on.</li> <li>2. Click the <b>Keyer</b> button for the key you want to perform the event on.</li> <li>3. Click the <b>Parameter</b> button and select <b>Y-Pos</b>.</li> <li>4. Click the <b>Change Type</b> button and select whether you want to set (<b>Absolute</b>) or reset (<b>Reset</b>) the parameter. Some selections will not be available when you reset the parameter.</li> <li>5. Enter a new position in the <b>Value (%)</b> field.</li> </ol> |
| Mask (Pattern) — Aspect Ratio              | Switcher > Keyer > Pattern Mask Param  | <p>Select the aspect ratio for the pattern mask for the selected ME.</p> <ol style="list-style-type: none"> <li>1. Click the <b>ME</b> button for the ME that you want to perform the event on.</li> <li>2. Click the <b>Parameter</b> button and select <b>Aspect</b>.</li> <li>3. Click the <b>Change Type</b> button and select whether you want to set (<b>Absolute</b>) or reset (<b>Reset</b>) the parameter. Some selections will not be available when you reset the parameter.</li> <li>4. Enter an aspect ratio in the <b>Value (%)</b> field.</li> </ol>  |
| Mask (Pattern) — Border Size               | Switcher > Keyer > Pattern Mask Param  | <p>Select the size of border for the pattern mask on the selected key for the selected ME.</p> <ol style="list-style-type: none"> <li>1. Click the <b>ME</b> button for the ME that you want to perform the event on.</li> <li>2. Click the <b>Parameter</b> button and select <b>Border Size</b>.</li> <li>3. Click the <b>Change Type</b> button and select whether you want to set (<b>Absolute</b>) or reset (<b>Reset</b>) the parameter. Some selections will not be available when you reset the parameter.</li> <li>4. Enter a size for the border in the <b>Value (%)</b> field.</li> </ol>   |
| Mask (Pattern) — Edge Softness             | Switcher > Keyer > Pattern Mask Param  | <p>Select the amount of softness to apply to the edge of the mask for the selected ME.</p> <ol style="list-style-type: none"> <li>1. Click the <b>ME</b> button for the ME that you want to perform the event on.</li> <li>2. Click the <b>Parameter</b> button and select <b>Softness</b>.</li> <li>3. Click the <b>Change Type</b> button and select whether you want to set (<b>Absolute</b>) or reset (<b>Reset</b>) the parameter. Some selections will not be available when you reset the parameter.</li> <li>4. Enter an amount of softness for the pattern or border in the <b>Value (%)</b> field.</li> </ol>  |
| Mask (Pattern) — Horizontal Multiplication | Switcher > Keyer > Pattern Mask Param  | <p>Select the number of times you want to multiply the pattern mask horizontally for the selected ME.</p> <ol style="list-style-type: none"> <li>1. Click the <b>ME</b> button for the ME that you want to perform the event on.</li> <li>2. Click the <b>Parameter</b> button and select <b>Horizontal Mult</b>.</li> <li>3. Click the <b>Change Type</b> button and select whether you want to set (<b>Absolute</b>) or reset (<b>Reset</b>) the parameter. Some selections will not be available when you reset the parameter.</li> <li>4. Enter the number of times the pattern is multiplied in the <b>Value</b> field.</li> </ol>                                      |
| Mask (Pattern) — Pattern                   | Switcher > Keyer > Pattern Mask Effect | <p>Select a pattern for the pattern mask for the selected ME.</p> <ol style="list-style-type: none"> <li>1. Click the <b>ME</b> button for the ME that you want to perform the event on.</li> <li>2. Click the <b>Pattern</b> and select the pattern you want to use for the pattern generator.</li> </ol>   |

| Event                                    | Location                              | Description   |
|--|---------------------------------------|---|
| Mask (Pattern) — Reset                   | Switcher > Keyer > Pattern Mask Reset | Reset the mask for the selected ME.<br><ol style="list-style-type: none"> <li>1. Click the <b>ME</b> button for the ME that you want to perform the event on.</li> <li>2. Click <b>Reset Params</b>.</li> </ol>   |
| Mask (Pattern) — Rotation                | Switcher > Keyer > Pattern Mask Param | Select the rotation for the pattern mask for the selected ME.<br><ol style="list-style-type: none"> <li>1. Click the <b>ME</b> button for the ME that you want to perform the event on.</li> <li>2. Click the <b>Parameter</b> button and select <b>Rotation</b>.</li> <li>3. Click the <b>Change Type</b> button and select whether you want to set (<b>Absolute</b>) or reset (<b>Reset</b>) the parameter. Some selections will not be available when you reset the parameter.</li> <li>4. Enter a rotation in the <b>Value (%)</b> field.</li> </ol>  |
| Mask (Pattern) — Size                    | Switcher > Keyer > Pattern Mask Param | Select the size of the pattern mask for the selected ME.<br><ol style="list-style-type: none"> <li>1. Click the <b>ME</b> button for the ME that you want to perform the event on.</li> <li>2. Click the <b>Parameter</b> button and select <b>Size</b>.</li> <li>3. Click the <b>Change Type</b> button and select whether you want to set (<b>Absolute</b>) or reset (<b>Reset</b>) the parameter. Some selections will not be available when you reset the parameter.</li> <li>4. Enter a new size in the <b>Value (%)</b> field.</li> </ol>   |
| Mask (Pattern) — Vertical Multiplication | Switcher > Keyer > Pattern Mask Param | Select the number of times you want to multiply the pattern mask vertically for the selected ME.<br><ol style="list-style-type: none"> <li>1. Click the <b>ME</b> button for the ME that you want to perform the event on.</li> <li>2. Click the <b>Parameter</b> button and select <b>Vertical Mult</b>.</li> <li>3. Click the <b>Change Type</b> button and select whether you want to set (<b>Absolute</b>) or reset (<b>Reset</b>) the parameter. Some selections will not be available when you reset the parameter.</li> <li>4. Enter the number of times the pattern is multiplied in the <b>Value</b> field.</li> </ol> |
| Mask (Pattern) — X-Position              | Switcher > Keyer > Pattern Mask Param | Select the x-axis position of the pattern mask for the selected ME.<br><ol style="list-style-type: none"> <li>1. Click the <b>ME</b> button for the ME that you want to perform the event on.</li> <li>2. Click the <b>Parameter</b> button and select <b>X-Pos</b>.</li> <li>3. Click the <b>Change Type</b> button and select whether you want to set (<b>Absolute</b>) or reset (<b>Reset</b>) the parameter. Some selections will not be available when you reset the parameter.</li> <li>4. Enter a new position in the <b>Value (%)</b> field.</li> </ol>   |
| Mask (Pattern) — Y-Position              | Switcher > Keyer > Pattern Mask Param | Select the y-axis position for the pattern mask for the selected ME.<br><ol style="list-style-type: none"> <li>1. Click the <b>ME</b> button for the ME that you want to perform the event on.</li> <li>2. Click the <b>Parameter</b> button and select <b>Y-Pos</b>.</li> <li>3. Click the <b>Change Type</b> button and select whether you want to set (<b>Absolute</b>) or reset (<b>Reset</b>) the parameter. Some selections will not be available when you reset the parameter.</li> <li>4. Enter a new position in the <b>Value (%)</b> field.</li> </ol>  |

| Event                       | Location                                | Description  |
|-----------------------------|---|--|
| Mask                        | Switcher > Keyer > Mask Type            | Apply a mask to the selected key for the selected ME. <ol style="list-style-type: none"> <li>Click the <b>ME</b> button for the ME that you want to perform the event on.</li> <li>Click the <b>Keyer</b> button for the key you want to perform the event on.</li> <li>Click a <b>Mask Type</b> button to apply a pattern mask (<b>Pattern</b>), box mask (<b>Box</b>), or turn the mask off (<b>Off</b>).</li> </ol>   |
| Matte Color, Reset          | Switcher > Matte > Matte Color Reset    | Reset the matte color for the selected ME or aux. <ol style="list-style-type: none"> <li>Click the <b>ME/Matte</b> button for the ME or aux that you want to perform the event on.</li> <li>For an ME, click the <b>Matte</b> button and select <b>Matte</b>.</li> </ol>   |
| Matte Color (HSL)           | Switcher > Matte > Matte Color (HSL)    | Select the custom matte color for the selected ME or aux. Each component of the HSL color must be inserted individually. <ol style="list-style-type: none"> <li>Click the <b>ME/Matte</b> button for the ME or aux that you want to perform the event on.</li> <li>Click the <b>Matte</b> button and select <b>Matte</b>.</li> <li>Click the <b>Change Type</b> button and select whether you want to set (<b>Absolute</b>) or reset (<b>Reset</b>) the parameter. Some selections will not be available when you reset the parameter.</li> <li>Click the <b>Component</b> button and select the HSL component you want to assign a value to. A value should be applied to all three components.</li> <li>Enter a value for the selected component in the <b>Value (%)</b> field.</li> </ol> |
| Matte Color (Preset)        | Switcher > Matte > Matte Color (Preset) | Select a preset matte color for the selected ME or aux. <ol style="list-style-type: none"> <li>Click the <b>ME/Matte</b> button for the ME or aux that you want to perform the event on.</li> <li>Click the <b>Matte</b> button and select <b>Matte</b>.</li> <li>Click the <b>Color</b> button and select the color you want to use.</li> </ol>   |
| ME Copy                     | Switcher > ME Copy                      | Copy the contents of one area to another. <ol style="list-style-type: none"> <li>Click the <b>Target ME</b> button and select the location that you want to copy to.</li> <li>Click the <b>Source ME</b> button and select the location that you want to copy from.</li> </ol>   |
| Media-Store — Auto Play     | Switcher > MediaStore > Attributes      | Select whether an animation plays automatically when taken on-air for the selected Media-Store channel. <ol style="list-style-type: none"> <li>Click the <b>MediaStore Channel</b> button for the Media-Store channel you want to perform the event on.</li> <li>Click the <b>Change Type</b> button and select whether you want to set (<b>Absolute</b>) or reset (<b>Reset</b>) the parameter. Some selections will not be available when you reset the parameter.</li> <li>Click the <b>Parameter</b> button and select <b>Auto Play</b>.</li> <li>Click the <b>Value</b> button and select whether the animation plays automatically (<b>On</b>) or not (<b>Off</b>).</li> </ol>   |
| Media-Store — Capture Alpha | Switcher > MediaStore > Capture Alpha   | Select whether to include the alpha with a capture on the selected Media-Store channel. <ol style="list-style-type: none"> <li>Click the <b>MediaStore Channel</b> button for the Media-Store channel you want to perform the event on.</li> <li>Click the <b>Change Type</b> button and select whether you want to set (<b>Absolute</b>) or reset (<b>Reset</b>) the parameter. Some selections will not be available when you reset the parameter.</li> <li>Click the <b>Enable</b> button and select whether the alpha is captured with the source (<b>On</b>) or not (<b>Off</b>).</li> </ol>  |



| Event                        | Location                                     | Description   |
|------------------------------|--|---|
| Media-Store — Capture        | Switcher > MediaStore > Capture              | <p>Capture a still to the selected Media-Store channel.</p> <ol style="list-style-type: none"> <li>1. Click the <b>MediaStore Channel</b> button for the Media-Store channel you want to perform the event on.</li> <li>2. Enter the number you want to assign to the capture file in the <b>Capture File</b> field.</li> </ol>   |
| Media-Store — Capture Mode   | Switcher > MediaStore > Capture Display      | <p>Select the capture mode for the selected Media-Store channel.</p> <ol style="list-style-type: none"> <li>1. Click the <b>MediaStore Channel</b> button for the Media-Store channel you want to perform the event on.</li> <li>2. Click a <b>Capture Display</b> button to select whether the capture is in electronic-to-electronic "E/E" (<b>End to End</b>) or playback "P/B" (<b>Playback</b>) mode.</li> </ol>   |
| Media-Store — Capture Source | Switcher > MediaStore > Media Capture Source | <p>Select the video source you want to capture for the selected Media-Store channel.</p> <ol style="list-style-type: none"> <li>1. Click the <b>MediaStore Channel</b> button for the Media-Store channel you want to perform the event on.</li> <li>2. Click <b>Source</b> and select the video source that you want to capture.</li> </ol>  |
| Media-Store — Clear Channel  | Switcher > MediaStore > Channel Action       | <p>Clear the selected Media-Store channel.</p> <ol style="list-style-type: none"> <li>1. Click the <b>MediaStore Channel</b> button for the Media-Store channel you want to perform the event on.</li> <li>2. Click <b>Clear Channel</b>.</li> </ol>  |
| Media-Store — Cut Frame      | Switcher > MediaStore > Attributes           | <p>Select the point, in frames, from the start of the animation that the MediaWipe background cut occurs for the selected Media-Store channel.</p> <ol style="list-style-type: none"> <li>1. Click the <b>MediaStore Channel</b> button for the Media-Store channel you want to perform the event on.</li> <li>2. Click the <b>Change Type</b> button and select whether you want to set (<b>Absolute</b>) or reset (<b>Reset</b>) the parameter. Some selections will not be available when you reset the parameter.</li> <li>3. Click the <b>Parameter</b> button and select <b>Cut Frame</b>.</li> <li>4. Enter the frame in the animation that you want to cut to occur for the MediaWipe in the <b>Value</b> field.</li> </ol> |
| Media-Store — Delete Capture | Switcher > MediaStore > Delete Media Capture | <p>Delete a captured still.</p> <ol style="list-style-type: none"> <li>1. Enter the number of the capture file you want to delete in the <b>Capture File</b> field.</li> </ol>  |
| Media-Store Load             | Switcher > MediaStore > Load                 | <p>Load a media item into the selected Media-Store channel.</p> <ol style="list-style-type: none"> <li>1. Click the <b>MediaStore Channel</b> button for the Media-Store channel you want to perform the event on.</li> <li>2. Click the <b>Location</b> button to select whether the media item you want to load is located on the internal storage (<b>Internal</b>) or on the USB (<b>USB</b>).</li> <li>3. Enter the number of the media item you want to load in the <b>Media Number</b> field.</li> </ol>   |
| Media-Store — Looping        | Switcher > MediaStore > Attributes           | <p>Select whether an animation will loop at the end for the selected Media-Store channel.</p> <ol style="list-style-type: none"> <li>1. Click the <b>MediaStore Channel</b> button for the Media-Store channel you want to perform the event on.</li> <li>2. Click the <b>Change Type</b> button and select whether you want to set (<b>Absolute</b>) or reset (<b>Reset</b>) the parameter. Some selections will not be available when you reset the parameter.</li> <li>3. Click the <b>Parameter</b> button and select <b>Looping</b>.</li> <li>4. Click the <b>Value</b> button and select whether the animation loops at the end (<b>On</b>) or not (<b>Off</b>).</li> </ol>   |

| Event                       | Location                               | Description  |
|-----------------------------|--|--|
| Media-Store — Move To Frame | Switcher > MediaStore > Attributes     | <p>Move to a specific frame in the media item for the selected Media-Store channel.</p> <ol style="list-style-type: none"> <li>1. Click the <b>MediaStore Channel</b> button for the Media-Store channel you want to perform the event on.</li> <li>2. Click the <b>Change Type</b> button and select whether you want to set (<b>Absolute</b>) or reset (<b>Reset</b>) the parameter. Some selections will not be available when you reset the parameter.</li> <li>3. Click the <b>Parameter</b> button and select <b>Move To Frame</b>.</li> <li>4. Enter the frame that you want to jump to in the media item in the <b>Value</b> field.</li> </ol>                                 |
| Media-Store — Mute          | Switcher > MediaStore > Attributes     | <p>Select whether the associated audio is turned on or off during playback for the selected Media-Store channel.</p> <ol style="list-style-type: none"> <li>1. Click the <b>MediaStore Channel</b> button for the Media-Store channel you want to perform the event on.</li> <li>2. Click the <b>Change Type</b> button and select whether you want to set (<b>Absolute</b>) or reset (<b>Reset</b>) the parameter. Some selections will not be available when you reset the parameter.</li> <li>3. Click the <b>Parameter</b> button and select <b>Mute</b>.</li> <li>4. Click the <b>Value</b> button and select whether the audio plays (<b>On</b>) or not (<b>Off</b>).</li> </ol> |
| Media-Store — Play          | Switcher > MediaStore > Channel Action | <p>Start an animation playing for the selected Media-Store channel.</p> <ol style="list-style-type: none"> <li>1. Click the <b>MediaStore Channel</b> button for the Media-Store channel you want to perform the event on.</li> <li>2. Click <b>Toggle Play</b>.</li> </ol>  |
| Media-Store — Play Speed    | Switcher > MediaStore > Playback Speed | <p>Select the speed for an animation to play at on the selected Media-Store channel.</p> <ol style="list-style-type: none"> <li>1. Click the <b>MediaStore Channel</b> button for the Media-Store channel you want to perform the event on.</li> <li>2. Click the <b>Change Type</b> button and select whether you want to set (<b>Absolute</b>) or reset (<b>Reset</b>) the parameter. Some selections will not be available when you reset the parameter.</li> <li>3. Click the <b>Parameter</b> button and select <b>Playback Speed</b>.</li> <li>4. Enter the speed, faster or slower than 100%, that you want the animation to play at in the <b>Value (%)</b> field.</li> </ol>  |
| Media-Store — Reset Media   | Switcher > MediaStore > Channel Action | <p>Reset the selected Media-Store channel.</p> <ol style="list-style-type: none"> <li>1. Click the <b>MediaStore Channel</b> button for the Media-Store channel you want to perform the event on.</li> <li>2. Click <b>Reset Media</b>.</li> </ol>   |
| Media-Store — Reverse       | Switcher > MediaStore > Attributes     | <p>Select whether an animation plays in reverse for the selected Media-Store channel.</p> <ol style="list-style-type: none"> <li>1. Click the <b>MediaStore Channel</b> button for the Media-Store channel you want to perform the event on.</li> <li>2. Click the <b>Change Type</b> button and select whether you want to set (<b>Absolute</b>) or reset (<b>Reset</b>) the parameter. Some selections will not be available when you reset the parameter.</li> <li>3. Click the <b>Parameter</b> button and select <b>Reverse</b>.</li> <li>4. Click the <b>Value</b> button and select whether the animation plays in reverse (<b>On</b>) or not (<b>Off</b>).</li> </ol>          |
| Media-Store — Rewind        | Switcher > MediaStore > Channel Action | <p>Rewind an animation to the first frame for the selected Media-Store channel.</p> <ol style="list-style-type: none"> <li>1. Click the <b>MediaStore Channel</b> button for the Media-Store channel you want to perform the event on.</li> <li>2. Click <b>Move to Frame 1</b>.</li> </ol>  |

| Event                                  | Location                                   | Description  |
|--|--|--|
| Media-Store — Shaped                   | Switcher > MediaStore > Attributes         | <p>Select whether the alpha of the media item should be shaped or unshaped for the selected Media-Store channel.</p> <ol style="list-style-type: none"> <li>1. Click the <b>MediaStore Channel</b> button for the Media-Store channel you want to perform the event on.</li> <li>2. Click the <b>Change Type</b> button and select whether you want to set (<b>Absolute</b>) or reset (<b>Reset</b>) the parameter. Some selections will not be available when you reset the parameter.</li> <li>3. Click the <b>Parameter</b> button and select <b>Shaped</b>.</li> <li>4. Click the <b>Value</b> button and select whether the alpha of the media item is shaped (<b>On</b>) or not (<b>Off</b>).</li> </ol> |
| Media-Store — Trigger GPI Output       | Switcher > MediaStore > Attributes         | <p>Select the GPI output that you want to trigger with a MediaWipe for the selected Media-Store channel.</p> <ol style="list-style-type: none"> <li>1. Click the <b>MediaStore Channel</b> button for the Media-Store channel you want to perform the event on.</li> <li>2. Click the <b>Change Type</b> button and select whether you want to set (<b>Absolute</b>) or reset (<b>Reset</b>) the parameter. Some selections will not be available when you reset the parameter.</li> <li>3. Click the <b>Parameter</b> button and select <b>GPO</b>.</li> <li>4. Enter the GPI output that you want to trigger with the MediaWipe in the <b>Value</b> field.</li> </ol>  |
| Media-Store — Trigger GPI Output Delay | Switcher > MediaStore > Attributes         | <p>Select the time from the start of the MediaWipe that the GPI output is triggered for the selected Media-Store channel.</p> <ol style="list-style-type: none"> <li>1. Click the <b>MediaStore Channel</b> button for the Media-Store channel you want to perform the event on.</li> <li>2. Click the <b>Change Type</b> button and select whether you want to set (<b>Absolute</b>) or reset (<b>Reset</b>) the parameter. Some selections will not be available when you reset the parameter.</li> <li>3. Click the <b>Parameter</b> button and select <b>GPO Frame</b>.</li> <li>4. Enter the delay, in frames, for the GPI output to be triggered in the <b>Value (fr)</b> field.</li> </ol>              |
| Media-Store — X-Position               | Switcher > MediaStore > Attributes         | <p>Select the x-axis position for the media item for the selected Media-Store channel.</p> <ol style="list-style-type: none"> <li>1. Click the <b>MediaStore Channel</b> button for the Media-Store channel you want to perform the event on.</li> <li>2. Click the <b>Change Type</b> button and select whether you want to set (<b>Absolute</b>) or reset (<b>Reset</b>) the parameter. Some selections will not be available when you reset the parameter.</li> <li>3. Click the <b>Parameter</b> button and select <b>X-Pos</b>.</li> <li>4. Enter a new position in the <b>Value</b> field.</li> </ol>  |
| Media-Store — Y-Position               | Switcher > MediaStore > Attributes         | <p>Select the y-axis position for the media item for the selected Media-Store channel.</p> <ol style="list-style-type: none"> <li>1. Click the <b>MediaStore Channel</b> button for the Media-Store channel you want to perform the event on.</li> <li>2. Click the <b>Change Type</b> button and select whether you want to set (<b>Absolute</b>) or reset (<b>Reset</b>) the parameter. Some selections will not be available when you reset the parameter.</li> <li>3. Click the <b>Parameter</b> button and select <b>Y-Pos</b>.</li> <li>4. Enter a new position in the <b>Value</b> field.</li> </ol>  |
| MediaWipe — Channel                    | Switcher > Transition > Media Wipe Channel | <p>Select which Media-Store channel will be used for the MediaWipe transition of the selected ME.</p> <ol style="list-style-type: none"> <li>1. Click the <b>ME</b> button for the ME that you want to perform the event on.</li> <li>2. Click <b>M1</b> or <b>M2</b> to assign that Media-Store channel to the MediaWipe.</li> </ol>  |

| Event                            | Location  | Description  |
|----------------------------------|---|--|
| MediaWipe Cut Point, Set         | Switcher > Transition > ME<br>Trans Action      | Sets the cut point for a MediaWipe transition for the selected area. You must select the point in the transition that you want to place the cut before running this event.<br><br><ol style="list-style-type: none"> <li>1. Click the <b>ME</b> button and select the area that you want to perform the event on.</li> <li>2. Click the <b>Action</b> button and select <b>Set Media Cut</b>.</li> </ol>   |
| MediaWipe — Direction, Flip-Flop | Switcher > Transition ><br>Media Wipe Direction | Select whether the MediaWipe reverses direction for every second transition of the selected ME.<br><br><ol style="list-style-type: none"> <li>1. Click the <b>ME</b> button for the ME that you want to perform the event on.</li> <li>2. Click the <b>Change Type</b> button and select whether you want to set (<b>Absolute</b>) or reset (<b>Reset</b>) the parameter. Some selections will not be available when you reset the parameter.</li> <li>3. Click <b>Flip-Flip</b>.</li> <li>4. Click the <b>Value</b> button and select whether Flip-Flop is on (<b>On</b>) or not (<b>Off</b>).</li> </ol>               |
| MediaWipe — Direction            | Switcher > Transition ><br>Media Wipe Direction | Select the direction for the MediaWipe transition of the selected ME.<br><br><ol style="list-style-type: none"> <li>1. Click the <b>ME</b> button for the ME that you want to perform the event on.</li> <li>2. Click the <b>Change Type</b> button and select whether you want to set (<b>Absolute</b>) or reset (<b>Reset</b>) the parameter. Some selections will not be available when you reset the parameter.</li> <li>3. Click <b>Direction</b>.</li> <li>4. Click the <b>Value</b> button and select whether the MediaWipe moves in a forward (<b>Forward</b>) or reverse (<b>Reverse</b>) direction.</li> </ol> |
| MediaWipe — Layer                | Switcher > Transition > ME<br>Media Trans Layer | Select which Media-Store channel will be used for the MediaWipe transition of the selected ME.<br><br><ol style="list-style-type: none"> <li>1. Click the <b>ME</b> button for the ME that you want to perform the event on.</li> <li>2. Click the <b>Layer</b> button to select what the MediaWipe animation covers.</li> </ol>   |
| MediaWipe Trans End Point, Set   | Switcher > Transition > ME<br>Trans Action      | Sets the ending point for a MediaWipe transition for the selected area. Use the fader to move through the animation to the point you want to end the transition and run this CC to save that point.<br><br><ol style="list-style-type: none"> <li>1. Click the <b>ME</b> button and select the area that you want to perform the event on.</li> <li>2. Click the <b>Action</b> button and select <b>Set Media Trans End</b>.</li> </ol>  |
| MediaWipe Trans Start Point, Set | Switcher > Transition > ME<br>Trans Action      | Sets the starting point for a MediaWipe transition for the selected area. Use the fader to move through the animation to the point you want to start the transition and run this CC to save that point.<br><br><ol style="list-style-type: none"> <li>1. Click the <b>ME</b> button and select the area that you want to perform the event on.</li> <li>2. Click the <b>Action</b> button and select <b>Set Media Trans Start</b>.</li> </ol>  |
| MediaWipe Trans Thumbnail        | Switcher > Transition > ME<br>Trans Action      | Sets the starting point for a MediaWipe transition for the selected area.<br><br><ol style="list-style-type: none"> <li>1. Click the <b>ME</b> button and select the area that you want to perform the event on.</li> <li>2. Click the <b>Action</b> button and select <b>Set Media Thumb</b>.</li> </ol>  |

| Event                       | Location  | Description  |
|-----------------------------|---|--|
| Memory Recall               | Switcher > Memory Recall                              | <p>Recall a memory for the selected area.</p> <ol style="list-style-type: none"> <li>1. Click the <b>Include</b> button and select all the locations that you want to perform the memory recall on.</li> <li>2. Click the <b>Bank</b> button and select the bank that you want to recall the memory on.</li> <li>3. Click the <b>Memory</b> button and select the memory that you want to recall.</li> </ol>   |
| ME Trans Rate               | Switcher > Transition > ME Trans Parameter            | <p>Set or reset the background transition rate of the selected area.</p> <ol style="list-style-type: none"> <li>1. Click the <b>ME</b> button and select the area that you want to perform the event on.</li> <li>2. Click the <b>Parameter</b> button and select <b>ME Trans Rate</b>.</li> <li>3. Click the <b>Change Type</b> button and select whether you want to set (<b>Absolute</b>) or reset (<b>Reset</b>) the parameter. Some selections will not be available when you reset the parameter.</li> <li>4. Enter a new transition rate, in frames, in the <b>Value (fr)</b> field.</li> </ol>   |
| ME Trans Type               | Switcher > Transition > ME Trans Type                 | <p>Select the transition type for a background transition of the selected area.</p> <ol style="list-style-type: none"> <li>1. Click the <b>ME</b> button and select the area that you want to perform the event on.</li> <li>2. Click the <b>Type</b> button for the type of transition you want to use.</li> </ol>  |
| MultiScreen — Edge Blending | Switcher Installation > MultiScreen > Edge Properties | <p>Select whether edge blending is applied to the edges of the overlapping edges for the selected MultiScreen.</p> <ol style="list-style-type: none"> <li>1. Click the <b>ME</b> button for the MultiScreen that you want to perform the event on.</li> <li>2. Click the <b>Parameter</b> button and select <b>Blending</b>.</li> <li>3. Click the <b>Change Type</b> button and select whether you want to set (<b>Absolute</b>) or reset (<b>Reset</b>) the parameter. Some selections will not be available when you reset the parameter.</li> <li>4. Click the <b>Edge</b> button and select the edge that you want to adjust.</li> <li>5. Click the <b>Value</b> button and select whether blending is applied edge (<b>On</b>) or not (<b>Off</b>).</li> </ol> |
| MultiScreen — Edge Distance | Switcher Installation > MultiScreen > Edge Parameters | <p>Select the distance between screens for the selected MultiScreen.</p> <ol style="list-style-type: none"> <li>1. Click the <b>ME</b> button for the MultiScreen that you want to perform the event on.</li> <li>2. Click the <b>Parameter</b> button and select <b>Distance</b>.</li> <li>3. Click the <b>Change Type</b> button and select whether you want to set (<b>Absolute</b>) or reset (<b>Reset</b>) the parameter. Some selections will not be available when you reset the parameter.</li> <li>4. Click the <b>Edge</b> button and select the edge that you want to adjust.</li> <li>5. Enter the distance between the screens on the selected edge in the <b>Value (%)</b> field.</li> </ol>   |

| Event                                  | Location  | Description   |
|--|---|---|
| MultiScreen — Edge Gamma               | Switcher Installation > MultiScreen > Edge Parameters | <p>Select the amount of gamma correction applied to the overlapping edges for the selected MultiScreen.</p> <ol style="list-style-type: none"> <li>1. Click the <b>ME</b> button for the MultiScreen that you want to perform the event on.</li> <li>2. Click the <b>Parameter</b> button and select <b>Gamma</b>.</li> <li>3. Click the <b>Change Type</b> button and select whether you want to set (<b>Absolute</b>) or reset (<b>Reset</b>) the parameter. Some selections will not be available when you reset the parameter.</li> <li>4. Click the <b>Edge</b> button and select the edge that you want to adjust.</li> <li>5. Enter the amount of gamma correction in the <b>Value (%)</b> field.</li> </ol> |
| MultiScreen — Edge Smoothness          | Switcher Installation > MultiScreen > Edge Parameters | <p>Select the amount of smoothing applied to the overlapping edges for the selected MultiScreen.</p> <ol style="list-style-type: none"> <li>1. Click the <b>ME</b> button for the MultiScreen that you want to perform the event on.</li> <li>2. Click the <b>Parameter</b> button and select <b>Smoothness</b>.</li> <li>3. Click the <b>Change Type</b> button and select whether you want to set (<b>Absolute</b>) or reset (<b>Reset</b>) the parameter. Some selections will not be available when you reset the parameter.</li> <li>4. Click the <b>Edge</b> button and select the edge that you want to adjust.</li> <li>5. Enter the amount of smoothing in the <b>Value (%)</b> field.</li> </ol>          |
| MultiScreen — Layout                   | Switcher Installation > MultiScreen > Layout          | <p>Select a layout for the selected MultiScreen.</p> <ol style="list-style-type: none"> <li>1. Click the <b>ME</b> button for the MultiScreen that you want to perform the event on.</li> <li>2. Click the <b>Layout</b> button and select the layout you want to use.</li> </ol>   |
| MultiScreen — Offset                   | Switcher Installation > MultiScreen > Offset          | <p>Select the placement of the background scaling for the selected MultiScreen.</p> <ol style="list-style-type: none"> <li>1. Click the <b>ME</b> button for the MultiScreen that you want to perform the event on.</li> <li>2. Click the <b>Parameter</b> button and select <b>Offset</b>.</li> <li>3. Click the <b>Change Type</b> button and select whether you want to set (<b>Absolute</b>) or reset (<b>Reset</b>) the parameter. Some selections will not be available when you reset the parameter.</li> <li>4. Enter the amount of offset in the <b>Value (%)</b> field.</li> </ol>  |
| MultiViewer Box — Aspect Ratio Markers | MultiViewer > Box > MV Box Aspect Ratio               | <p>Select whether aspect ratio markers are shown for the selected box on the selected MultiViewer.</p> <ol style="list-style-type: none"> <li>1. Click a <b>MultiViewer</b> button to select which MultiViewer you want that you want to perform the event on.</li> <li>2. Click the <b>Box</b> button and select the box that you want perform the event on.</li> <li>3. Click the <b>Change Type</b> button and select whether you want to set (<b>Absolute</b>) or reset (<b>Reset</b>) the parameter. Some selections will not be available when you reset the parameter.</li> <li>4. Click a <b>Value</b> button and select whether aspect ratio markers are shown (<b>On</b>) or not (<b>Off</b>).</li> </ol> |

| Event                                   | Location                                     | Description  |
|---|--|--|
| MultiViewer Box — Border                | MultiViewer > Box > MV<br>Box Border Mode    | Select the type of border you want to apply to the selected box on the selected MultiViewer. <ol style="list-style-type: none"> <li>1. Click a <b>MultiViewer</b> button to select which MultiViewer you want that you want to perform the event on.</li> <li>2. Click the <b>Box</b> button and select the box that you want perform the event on.</li> <li>3. Click a <b>Border Mode</b> button and select whether the border around the selected box is white (<b>White</b>), black (<b>Black</b>), or if there is no border (<b>Off</b>).</li> </ol>   |
| MultiViewer Box — Green Tally (Preview) | MultiViewer > Box > MV<br>Box Preview Tally  | Select whether a green (preview) tally is shown for the selected box on the selected MultiViewer. <ol style="list-style-type: none"> <li>1. Click a <b>MultiViewer</b> button to select which MultiViewer you want that you want to perform the event on.</li> <li>2. Click the <b>Box</b> button and select the box that you want perform the event on.</li> <li>3. Click the <b>Change Type</b> button and select whether you want to set (<b>Absolute</b>) or reset (<b>Reset</b>) the parameter. Some selections will not be available when you reset the parameter.</li> <li>4. Click a <b>Value</b> button and select whether a green tally is shown on the selected box (<b>On</b>) or not (<b>Off</b>).</li> </ol>   |
| MultiViewer Box — Label                 | MultiViewer > Box > MV<br>Box Label          | Select whether the source label is on or off for the selected box on the selected MultiViewer. <ol style="list-style-type: none"> <li>1. Click a <b>MultiViewer</b> button to select which MultiViewer you want that you want to perform the event on.</li> <li>2. Click the <b>Box</b> button and select the box that you want perform the event on.</li> <li>3. Click the <b>Change Type</b> button and select whether you want to set (<b>Absolute</b>) or reset (<b>Reset</b>) the parameter. Some selections will not be available when you reset the parameter.</li> <li>4. Click a <b>Value</b> button and select whether the label on the selected box is on (<b>On</b>) or not (<b>Off</b>).</li> </ol>   |
| MultiViewer Box — Label Mode            | MultiViewer > Box > MV<br>Box Label Mode     | Select what source name is shown on the label for the selected box on the selected MultiViewer. This event only applies to the Carbonite eXtreme. <ol style="list-style-type: none"> <li>1. Click a <b>MultiViewer</b> button to select which MultiViewer you want that you want to perform the event on.</li> <li>2. Click the <b>Box</b> button and select the box that you want perform the event on.</li> <li>3. Click the <b>Change Type</b> button and select whether you want to set (<b>Absolute</b>) or reset (<b>Reset</b>) the parameter. Some selections will not be available when you reset the parameter.</li> <li>4. Click a <b>Label Mode</b> button and select whether the name comes from the switcher (<b>Switcher</b>), the router (<b>Router</b>), or both are shown (<b>Both</b>).</li> </ol> |
| MultiViewer Box — Label Position        | MultiViewer > Box > MV<br>Box Label Position | Select the position of the source label for the selected box on the selected MultiViewer. <ol style="list-style-type: none"> <li>1. Click a <b>MultiViewer</b> button to select which MultiViewer you want that you want to perform the event on.</li> <li>2. Click the <b>Box</b> button and select the box that you want perform the event on.</li> <li>3. Click the <b>Change Type</b> button and select whether you want to set (<b>Absolute</b>) or reset (<b>Reset</b>) the parameter. Some selections will not be available when you reset the parameter.</li> <li>4. Click a <b>Value</b> button and select whether the label on the selected box is at the top (<b>Top</b>) or bottom (<b>Bottom</b>).</li> </ol>   |



| Event   | Location                                      | Description   |
|---|---|---|
| MultiViewer Box — Label Transparency          | MultiViewer > MV Label Transp                 | <p>Select transparency for the background behind the source labels on the selected MultiViewer.</p> <ol style="list-style-type: none"> <li>1. Click a <b>MultiViewer</b> button to select which MultiViewer you want that you want to perform the event on.</li> <li>2. Click the <b>Change Type</b> button and select whether you want to set (<b>Absolute</b>) or reset (<b>Reset</b>) the parameter. Some selections will not be available when you reset the parameter.</li> <li>3. Enter the amount of transparency in the <b>Value (%)</b> field.</li> </ol>  |
| MultiViewer Box — MultiScreen Markers         | MultiViewer > Box > MV Box MultiScreen Marker | <p>Select whether the MultiScreen overlay is shown for the selected box on the selected MultiViewer. The overlay shows what portions of the image are cropped out to fit into the output of the MultiScreen.</p> <ol style="list-style-type: none"> <li>1. Click a <b>MultiViewer</b> button to select which MultiViewer you want that you want to perform the event on.</li> <li>2. Click the <b>Box</b> button and select the box that you want perform the event on.</li> <li>3. Click the <b>ME</b> button and select the MultiScreen you want to view.</li> <li>4. Click the <b>Change Type</b> button and select whether you want to set (<b>Absolute</b>) or reset (<b>Reset</b>) the parameter. Some selections will not be available when you reset the parameter.</li> <li>5. Click a <b>Value</b> button and select whether the overlay is shown (<b>On</b>) or not (<b>Off</b>).</li> </ol> |
| MultiViewer Box — Red Tally (On-Air)          | MultiViewer > Box > MV Box On-Air Tally       | <p>Select whether a red (on-air) tally is shown for the selected box on the selected MultiViewer.</p> <ol style="list-style-type: none"> <li>1. Click a <b>MultiViewer</b> button to select which MultiViewer you want that you want to perform the event on.</li> <li>2. Click the <b>Box</b> button and select the box that you want perform the event on.</li> <li>3. Click the <b>Change Type</b> button and select whether you want to set (<b>Absolute</b>) or reset (<b>Reset</b>) the parameter. Some selections will not be available when you reset the parameter.</li> <li>4. Click a <b>Value</b> button and select whether a red tally is shown on the selected box (<b>On</b>) or not (<b>Off</b>).</li> </ol>  |
| MultiViewer Box — Video Source                | MultiViewer > Box > MV Box Source             | <p>Assign a source to one of the boxes on the selected MultiViewer.</p> <ol style="list-style-type: none"> <li>1. Click a <b>MultiViewer</b> button to select which MultiViewer you want that you want to perform the event on.</li> <li>2. Click the <b>Box</b> button and select the box that you want perform the event on.</li> <li>3. Click the <b>Value</b> button and select the source that you want to assign to the box.</li> </ol>   |
| MultiViewer — Clip                            | MultiViewer > MV Keyer Clip                   | <p>Select the amount of clipping to be applied to the overlay source on the selected MultiViewer.</p> <ol style="list-style-type: none"> <li>1. Click a <b>MultiViewer</b> button to select which MultiViewer you want that you want to perform the event on.</li> <li>2. Click the <b>Change Type</b> button and select whether you want to set (<b>Absolute</b>) or reset (<b>Reset</b>) the parameter. Some selections will not be available when you reset the parameter.</li> <li>3. Enter the amount of clipping to be applied in the <b>Value</b> field.</li> </ol>  |
| MultiViewer Clock — Background Color (Preset) | MultiViewer > Clock > MV Clock (Preset Color) | <p>Select a preset color for the background of the clock on the selected MultiViewer.</p> <ol style="list-style-type: none"> <li>1. Click a <b>MultiViewer</b> button to select which MultiViewer you want that you want to perform the event on.</li> <li>2. Click <b>Background</b>.</li> <li>3. Click the <b>Color</b> button and select the color you want to use.</li> </ol>   |

| Event   | Location                                      | Description   |
|---|---|---|
| MultiViewer Clock — Foreground Color (HSL)    | MultiViewer > Clock > MV Clock (HSL Color)    | <p>Select the custom color for the lettering of the clock on the selected MultiViewer.</p> <ol style="list-style-type: none"> <li>1. Click a <b>MultiViewer</b> button to select which MultiViewer you want that you want to perform the event on.</li> <li>2. Click the <b>Clock Area</b> button and select <b>Foreground</b>.</li> <li>3. Click the <b>Change Type</b> button and select whether you want to set (<b>Absolute</b>) or reset (<b>Reset</b>) the parameter. Some selections will not be available when you reset the parameter.</li> <li>4. Click the <b>Component</b> button and select the HSL component you want to assign a value to. A value should be applied to all three components.</li> <li>5. Enter a value for the selected component in the <b>Value (%)</b> field.</li> </ol> |
| MultiViewer Clock — Foreground Color (Preset) | MultiViewer > Clock > MV Clock (Preset Color) | <p>Select a preset color for the lettering of the clock on the selected MultiViewer.</p> <ol style="list-style-type: none"> <li>1. Click a <b>MultiViewer</b> button to select which MultiViewer you want that you want to perform the event on.</li> <li>2. Click <b>Foreground</b>.</li> <li>3. Click the <b>Color</b> button and select the color you want to use.</li> </ol>  |
| MultiViewer Clock — Format                    | MultiViewer > Clock > MV Clock Format         | <p>Select the hour format for the clock on the selected MultiViewer.</p> <ol style="list-style-type: none"> <li>1. Click a <b>MultiViewer</b> button to select which MultiViewer you want that you want to perform the event on.</li> <li>2. Click a <b>Value</b> button and select whether the clock shows 24-hour (<b>24-Hours</b>), 12-hour with am/pm (<b>12-Hour AM/PM</b>), or simple 12-hour (<b>12-Hour</b>) clock.</li> </ol>  |
| MultiViewer Clock — Mode                      | MultiViewer > Clock > MV Clock Mode           | <p>Select whether the clock shows timecode or system time on the selected MultiViewer.</p> <ol style="list-style-type: none"> <li>1. Click a <b>MultiViewer</b> button to select which MultiViewer you want that you want to perform the event on.</li> <li>2. Click a <b>Clock Mode</b> button and select whether the clock shows timecode (<b>Timecode</b>), system time (<b>System</b>), or is off (<b>Off</b>).</li> </ol>  |
| MultiViewer Clock — Size                      | MultiViewer > Clock > MV Clock Param          | <p>Select the size of the clock on the selected MultiViewer.</p> <ol style="list-style-type: none"> <li>1. Click a <b>MultiViewer</b> button to select which MultiViewer you want that you want to perform the event on.</li> <li>2. Click <b>Clock Size</b>.</li> <li>3. Click the <b>Change Type</b> button and select whether you want to set (<b>Absolute</b>) or reset (<b>Reset</b>) the parameter. Some selections will not be available when you reset the parameter.</li> <li>4. Enter the size of the clock in the <b>Value (%)</b> field.</li> </ol>   |
| MultiViewer Clock — Timecode Frame Count      | MultiViewer > Clock > MV Clock Frame Count    | <p>Select whether number of frames for a timecode are shown on the selected MultiViewer.</p> <ol style="list-style-type: none"> <li>1. Click a <b>MultiViewer</b> button to select which MultiViewer you want that you want to perform the event on.</li> <li>2. Click the <b>Change Type</b> button and select whether you want to set (<b>Absolute</b>) or reset (<b>Reset</b>) the parameter. Some selections will not be available when you reset the parameter.</li> <li>3. Click a <b>Value</b> button and select whether the frame count is shown (<b>On</b>) or not (<b>Off</b>).</li> </ol>  |

| Event                          | Location                                   | Description  |
|--------------------------------|--|--|
| MultiViewer Clock — X-Position | MultiViewer > Clock > MV Clock Param       | <p>Select the horizontal position of the clock on the selected MultiViewer.</p> <ol style="list-style-type: none"> <li>1. Click a <b>MultiViewer</b> button to select which MultiViewer you want that you want to perform the event on.</li> <li>2. Click <b>Clock X-Pos</b>.</li> <li>3. Click the <b>Change Type</b> button and select whether you want to set (<b>Absolute</b>) or reset (<b>Reset</b>) the parameter. Some selections will not be available when you reset the parameter.</li> <li>4. Enter the horizontal position of the clock in the <b>Value (%)</b> field.</li> </ol>   |
| MultiViewer                    | MultiViewer > Clock > MV Clock (HSL Color) | <p>Select the custom color for the background of the clock on the selected MultiViewer.</p> <ol style="list-style-type: none"> <li>1. Click a <b>MultiViewer</b> button to select which MultiViewer you want that you want to perform the event on.</li> <li>2. Click the <b>Clock Area</b> button and select <b>Background</b>.</li> <li>3. Click the <b>Change Type</b> button and select whether you want to set (<b>Absolute</b>) or reset (<b>Reset</b>) the parameter. Some selections will not be available when you reset the parameter.</li> <li>4. Click the <b>Component</b> button and select the HSL component you want to assign a value to. A value should be applied to all three components.</li> <li>5. Enter a value for the selected component in the <b>Value (%)</b> field.</li> </ol> |
| MultiViewer — FSFC Label       | MultiViewer > MV FSFC Label                | <p>Select whether FSFC is shown on the label on the selected MultiViewer when a source has an FSFC applies to it.</p> <ol style="list-style-type: none"> <li>1. Click a <b>MultiViewer</b> button to select which MultiViewer you want that you want to perform the event on.</li> <li>2. Click the <b>Change Type</b> button and select whether you want to set (<b>Absolute</b>) or reset (<b>Reset</b>) the parameter. Some selections will not be available when you reset the parameter.</li> <li>3. Click a <b>Value</b> button to select whether FSFC is shown on the label (<b>On</b>) or not (<b>Off</b>).</li> </ol>   |
| MultiViewer — Layout           | MultiViewer > MV Layout                    | <p>Select a layout for the selected MultiViewer.</p> <ol style="list-style-type: none"> <li>1. Click a <b>MultiViewer</b> button to select which MultiViewer you want that you want to perform the event on.</li> <li>2. Click the <b>Layout</b> button and select the layout you want to use.</li> </ol>  |
| MultiViewer — Outputs          | Switcher Installation > Output Mode        | <p>Select which outputs the MultiViewer is available on. This feature is only available when the switcher is operating in a standard-definition or 3G video mode.</p> <ol style="list-style-type: none"> <li>1. Click an <b>Outputs</b> button to select which pair of output BNCs you want to assign to as MultiViewer outputs.</li> <li>2. Click a <b>Lock MultiViewers</b> button to assign the selected output BNCs as MultiViewer outputs (<b>On</b>) or not (<b>Off</b>).</li> </ol>   |
| MultiViewer — Tally Display    | MultiViewer > MV Tally Display             | <p>Select how the tallies are shown on the selected MultiViewer.</p> <ol style="list-style-type: none"> <li>1. Click a <b>MultiViewer</b> button to select which MultiViewer you want that you want to perform the event on.</li> <li>2. Click a <b>Tally Display</b> button to select whether tallies are shown as a border around the box (<b>Box</b>), as boxes on either side of the label (<b>Label</b>), or as boxes on either side of the label but swapped (<b>Label Reverse</b>).</li> </ol>  |

| Event                                       | Location  | Description   |
|---|---|---|
| Output BNC Assignment                       | Switcher Installation > Output Assignment       | Assign a source to the selected output BNC.<br><ol style="list-style-type: none"> <li>1. Click the <b>Output</b> button and select the output BNC that you want to assign a source to.</li> <li>2. Click the <b>Source</b> button and select the source that you want to assign to the selected output BNC.</li> </ol>  |
| Pause CC                                    | Special > Hold                                  | Insert a pause into the custom control.<br><ol style="list-style-type: none"> <li>1. Enter the length of the pause in the <b>Pause (fr)</b> field.</li> </ol>   |
| PBus — Recall                               | Devices > PBus                                  | Recall a register on the selected PBus device.<br><ol style="list-style-type: none"> <li>1. Click <b>PBus Recall Register</b>.</li> <li>2. Click the <b>PBus</b> button and select the device you want to send the command to.</li> <li>3. Click the <b>Device</b> button and select the channel you want to send the command to.</li> <li>4. Click the <b>Change Type</b> button and select whether you want to set (<b>Absolute</b>) or reset (<b>Reset</b>) the parameter. Some selections will not be available when you reset the parameter.</li> <li>5. Enter number of the register you want to recall in the <b>Register</b> field.</li> </ol>  |
| PBus — Trigger                              | Devices > PBus                                  | Trigger a function on the selected PBus device.<br><ol style="list-style-type: none"> <li>1. Click <b>PBus Trigger Function</b>.</li> <li>2. Click the <b>PBus</b> button and select the device you want to send the command to.</li> <li>3. Click the <b>Device</b> button and select the channel you want to send the command to.</li> <li>4. Click the <b>Change Type</b> button and select whether you want to set (<b>Absolute</b>) or reset (<b>Reset</b>) the parameter. Some selections will not be available when you reset the parameter.</li> <li>5. Enter the number of the function you want to trigger in the <b>Function</b> field.</li> </ol>   |
| Personality — Auto Remove Key               | Switcher Personality > Auto Remove Key          | Have a key removed from the Next Transition area, so that it is not included in the next transition, after it has been transitioned off-air using the <b>KEY X CUT</b> or <b>KEY X AUTO</b> buttons.<br><ol style="list-style-type: none"> <li>1. Click the <b>Change Type</b> button and select whether you want to set (<b>Absolute</b>) or reset (<b>Reset</b>) the parameter. Some selections will not be available when you reset the parameter.</li> <li>2. Click the <b>Value</b> button and select whether the personality option is on (<b>On</b>) or not (<b>Off</b>).</li> </ol>   |
| Personality — Auto Trans Second Press (Key) | Switcher Personality > Key Auto Trans 2nd Press | Select how the switcher reacts when the <b>KEY AUTO</b> button is pressed during a transition.<br><ol style="list-style-type: none"> <li>1. Click the <b>Second Auto</b> button and select how the switcher reacts to pressing the button during a transition. <ul style="list-style-type: none"> <li>• <b>Ignore</b> — the buttons are ignored during the transition</li> <li>• <b>Halt Forward</b> — halt the transition and move forward through the transition when pressed again</li> <li>• <b>Halt Reverse</b> — halt the transition and move backwards through the transition when pressed again</li> <li>• <b>Reverse</b> — reverse the transition immediately</li> <li>• <b>Cut</b> — cut the transition to the end</li> </ul> </li> </ol> |

| Event                                      | Location  | Description   |
|--|---|---|
| Personality — Auto Trans Second Press (ME) | Switcher Personality > ME Auto Trans 2nd Press      | Select how the switcher reacts when the <b>AUTO TRANS</b> button is pressed during a transition. <ol style="list-style-type: none"> <li>Click the <b>Second Auto</b> button and select how the switcher reacts to pressing the button during a transition. <ul style="list-style-type: none"> <li><b>Ignore</b> — the buttons are ignored during the transition</li> <li><b>Halt Forward</b> — halt the transition and move forward through the transition when pressed again</li> <li><b>Halt Reverse</b> — halt the transition and move backwards through the transition when pressed again</li> <li><b>Reverse</b> — reverse the transition immediately</li> <li><b>Cut</b> — cut the transition to the end</li> </ul> </li> </ol> |
| Personality — Next Trans Reset             | Switcher Personality > Auto Reset Trans             | Have the transition area reset to a default background dissolve after each transition. <ol style="list-style-type: none"> <li>Click the <b>Change Type</b> button and select whether you want to set (<b>Absolute</b>) or reset (<b>Reset</b>) the parameter. Some selections will not be available when you reset the parameter.</li> <li>Click the <b>Value</b> button and select whether the personality option is on (<b>On</b>) or not (<b>Off</b>).</li> </ol>  |
| Personality — Roll Clip                    | Switcher Personality > Roll Clip Force              | Select whether the Roll Clip functionality is always on. <ol style="list-style-type: none"> <li>Click a <b>Value</b> button to select whether Roll Clip is always on (<b>Force</b>) or must be turned on manually (<b>User</b>).</li> </ol>   |
| Play CC                                    | Special > Play CC                                   | Play a custom control. <b>Note:</b> The Play CC command applies to a target custom control button only. If you move the contents of the custom control from the button selected in the Play CC to another button, the Play CC command will not follow and will continue to play the custom control assigned to the original button. <ol style="list-style-type: none"> <li>Click the <b>Bank</b> button and select the custom control bank you want to play a custom control on.</li> <li>Click the <b>CC</b> button and select the custom control you want to play.</li> </ol>   |
| Reference Source                           | Switcher Installation > Reference > Video Reference | Select the reference source for the switcher. <ol style="list-style-type: none"> <li>Click a <b>Reference Source</b> button to select whether to use an internal (<b>Internal</b>) or external (<b>External</b>) reference source.</li> </ol>   |
| Reset                                      | Switcher > Transition > ME Trans Action             | Resets the transition area of the selected area. <ol style="list-style-type: none"> <li>Click the <b>ME</b> button and select the area that you want to perform the event on.</li> <li>Click the <b>Action</b> button and select <b>Reset</b>.</li> </ol>   |
| Resume CC                                  | Special > Resume CC                                 | Resume a custom control at hold. <ol style="list-style-type: none"> <li>Click the <b>Bank</b> button and select the custom control bank you want to resume a custom control on.</li> <li>Click the <b>CC</b> button and select the custom control you want to resume.</li> </ol>  |
| Robotic Camera — Halt All                  | Devices > Camera                                    | Send the halt command to the selected camera. <ol style="list-style-type: none"> <li>Click <b>Camera Halt All</b>.</li> <li>Click the <b>Camera</b> button and select the device you want to send the command to.</li> </ol>  |

| Event                             | Location                          | Description   |
|-----------------------------------|-----------------------------------|---|
| Robotic Camera — Recall Shot      | Devices > Camera                  | <p>Recall a shot on the selected camera at the rate/speed set in the shot.</p> <ol style="list-style-type: none"> <li>1. Click <b>Recall Shot</b>.</li> <li>2. Click the <b>Camera</b> button and select the device you want to send the command to.</li> <li>3. Click the <b>Channel</b> button and select the channel you want to send the command to.</li> <li>4. Click the <b>Change Type</b> button and select whether you want to set (<b>Absolute</b>) or reset (<b>Reset</b>) the parameter. Some selections will not be available when you reset the parameter.</li> <li>5. Enter the shot number you want to recall from in the <b>Shot</b> field.</li> </ol> |
| Robotic Camera — Recall Shot Fast | Devices > Camera                  | <p>Recall a shot on the selected camera as quickly as possible.</p> <ol style="list-style-type: none"> <li>1. Click <b>Recall Shot (Fast)</b>.</li> <li>2. Click the <b>Camera</b> button and select the device you want to send the command to.</li> <li>3. Click the <b>Channel</b> button and select the channel you want to send the command to.</li> <li>4. Click the <b>Change Type</b> button and select whether you want to set (<b>Absolute</b>) or reset (<b>Reset</b>) the parameter. Some selections will not be available when you reset the parameter.</li> <li>5. Enter the shot number you want to recall from in the <b>Shot</b> field.</li> </ol>     |
| Robotic Camera — Store Shot       | Devices > Camera                  | <p>Store a shot on the selected camera.</p> <ol style="list-style-type: none"> <li>1. Click <b>Store Shot</b>.</li> <li>2. Click the <b>Camera</b> button and select the device you want to send the command to.</li> <li>3. Click the <b>Channel</b> button and select the channel you want to send the command to.</li> <li>4. Click the <b>Change Type</b> button and select whether you want to set (<b>Absolute</b>) or reset (<b>Reset</b>) the parameter. Some selections will not be available when you reset the parameter.</li> <li>5. Enter the shot number you want to store to in the <b>Shot</b> field.</li> </ol>  |
| Roll Clip                         | Switcher > Transition > Roll Clip | <p>Turn the Roll Clip feature on or off for the selected area.</p> <ol style="list-style-type: none"> <li>1. Click the <b>ME</b> button and select the area that you want to perform the event on.</li> <li>2. Click the <b>Value</b> button and select whether roll clip is on (<b>On</b>) or not (<b>Off</b>).</li> </ol>   |
| RossTalk CC                       | Devices > RossTalk                | <p>Send the simulated custom control to the selected device.</p> <ol style="list-style-type: none"> <li>1. Click <b>CC</b>.</li> <li>2. Click the <b>RossTalk Device</b> button and select the device you want to send the RossTalk command to.</li> <li>3. Enter the bank of the custom control in the <b>Bank</b> field.</li> <li>4. Enter the number of the custom control in the <b>Custom</b> field.</li> </ol>  |
| RossTalk Clear                    | Devices > RossTalk                | <p>Send the Clear Framebuffer command for a framebuffer and layer to the selected device.</p> <ol style="list-style-type: none"> <li>1. Click <b>Clear Channel</b>.</li> <li>2. Click the <b>RossTalk Device</b> button and select the device you want to send the RossTalk command to.</li> <li>3. Enter the framebuffer that you want to clear in the <b>Channel</b> field.</li> <li>4. Enter the layer that you want to clear in the <b>Layer</b> field.</li> </ol>  |

| Event                                       | Location           | Description   |
|---|--------------------|---|
| RossTalk — Cue (item + framebuffer)         | Devices > RossTalk | Send the Cue command for a specific item and framebuffer to the selected device. <ol style="list-style-type: none"> <li>1. Click <b>Cue (2)</b>.</li> <li>2. Click the <b>RossTalk Device</b> button and select the device you want to send the RossTalk command to.</li> <li>3. Enter the take item id of the item you want to cue in the <b>Take ID</b> field.</li> <li>4. Enter the framebuffer that you want to cue the item on in the <b>Channel</b> field.</li> </ol>   |
| RossTalk — Cue (item + framebuffer + layer) | Devices > RossTalk | Send the Cue command for a specific item and location to the selected device. <ol style="list-style-type: none"> <li>1. Click <b>Cue (3)</b>.</li> <li>2. Click the <b>RossTalk Device</b> button and select the device you want to send the RossTalk command to.</li> <li>3. Enter the take item id of the item you want to cue in the <b>Take ID</b> field.</li> <li>4. Enter the framebuffer that you want to cue the item on in the <b>Channel</b> field.</li> <li>5. Enter the layer that you want to cue the item on in the <b>Layer</b> field.</li> </ol>  |
| RossTalk — Cue Current                      | Devices > RossTalk | Send the Cue command to the selected device. <ol style="list-style-type: none"> <li>1. Click <b>Cue</b>.</li> <li>2. Click the <b>RossTalk Device</b> button and select the device you want to send the RossTalk command to.</li> </ol>   |
| RossTalk Custom Command                     | Devices > RossTalk | Send a manual RossTalk string to the selected device. <ol style="list-style-type: none"> <li>1. Click a <b>RossTalk CustomCmd</b> button for how you want the custom control command message to be formatted. <ul style="list-style-type: none"> <li>• <b>CRLF</b> — message ends with a carriage return and a line feed.</li> <li>• <b>CR</b> — message ends with a carriage return.</li> <li>• <b>LF</b> — message ends with a line feed.</li> <li>• <b>no CRLF</b> — message ends without a carriage return or a line feed.</li> </ul> </li> <li>2. Click the <b>RossTalk Device</b> button and select the device you want to send the RossTalk command to.</li> <li>3. Enter the RossTalk string in the <b>Custom Cmd</b> field.</li> </ol> |
| RossTalk — Focus                            | Devices > RossTalk | Send the Focus command for a specific item to the selected device. <ol style="list-style-type: none"> <li>1. Click <b>Focus</b>.</li> <li>2. Click the <b>RossTalk Device</b> button and select the device you want to send the RossTalk command to.</li> <li>3. Enter the take item id of the item you want to have focus in the <b>Take ID</b> field.</li> </ol>  |
| RossTalk — GPI                              | Devices > RossTalk | Send the simulated GPI input to the selected device. <ol style="list-style-type: none"> <li>1. Click <b>GPI</b>.</li> <li>2. Click the <b>RossTalk Device</b> button and select the device you want to send the RossTalk command to.</li> <li>3. Enter the GPI you want to simulate triggering in the <b>GPI</b> field.</li> </ol>  |
| RossTalk — Next                             | Devices > RossTalk | Send the Next command to the selected device. <ol style="list-style-type: none"> <li>1. Click <b>Take Next</b>.</li> <li>2. Click the <b>RossTalk Device</b> button and select the device you want to send the RossTalk command to.</li> </ol>  |



| Event                     | Location           | Description  |
|---------------------------|--------------------|--|
| RossTalk — Read           | Devices > RossTalk | Send the Read command for a specific item and layer to the selected device.<br><ol style="list-style-type: none"> <li>1. Click <b>Read</b>.</li> <li>2. Click the <b>RossTalk Device</b> button and select the device you want to send the RossTalk command to.</li> <li>3. Enter the take item id of the item you want to read in the <b>Take ID</b> field.</li> <li>4. Enter the layer that you want to cue the item on in the <b>Layer</b> field.</li> </ol>      |
| RossTalk — Resume         | Devices > RossTalk | Send the Resume command for a framebuffer and layer to the selected device.<br><ol style="list-style-type: none"> <li>1. Click <b>Resume Channel</b>.</li> <li>2. Click the <b>RossTalk Device</b> button and select the device you want to send the RossTalk command to.</li> <li>3. Enter the framebuffer that you want to resume in the <b>Channel</b> field.</li> <li>4. Enter the layer that you want to resume in the <b>Layer</b> field.</li> </ol>           |
| RossTalk — Sequencer Down | Devices > RossTalk | Send the Sequencer Down command to the selected device.<br><ol style="list-style-type: none"> <li>1. Click <b>Sequencer Down</b>.</li> <li>2. Click the <b>RossTalk Device</b> button and select the device you want to send the RossTalk command to.</li> </ol>   |
| RossTalk — Sequencer Up   | Devices > RossTalk | Send the Sequencer Up command to the selected device.<br><ol style="list-style-type: none"> <li>1. Click <b>Sequencer Up</b>.</li> <li>2. Click the <b>RossTalk Device</b> button and select the device you want to send the RossTalk command to.</li> </ol>   |
| RossTalk — Swap Current   | Devices > RossTalk | Send the Swap command to the selected device.<br><ol style="list-style-type: none"> <li>1. Click <b>Swap</b>.</li> <li>2. Click the <b>RossTalk Device</b> button and select the device you want to send the RossTalk command to.</li> </ol>   |
| RossTalk — Swap           | Devices > RossTalk | Send the Swap command for a specific location to the selected device.<br><ol style="list-style-type: none"> <li>1. Click <b>Swap (2)</b>.</li> <li>2. Click the <b>RossTalk Device</b> button and select the device you want to send the RossTalk command to.</li> <li>3. Enter the framebuffer that you want to swap the items on in the <b>Channel</b> field.</li> <li>4. Enter the layer that you want to swap the items on in the <b>Layer</b> field.</li> </ol> |
| RossTalk — Take Current   | Devices > RossTalk | Send the Take command to the selected device.<br><ol style="list-style-type: none"> <li>1. Click <b>Take</b>.</li> <li>2. Click the <b>RossTalk Device</b> button and select the device you want to send the RossTalk command to.</li> </ol>   |

| Event                       | Location   | Description  |
|-----------------------------|--|--|
| RossTalk — Take             | Devices > RossTalk   | Send the Take command for a specific item and location to the selected device. <ol style="list-style-type: none"> <li>Click <b>Take (3)</b>.</li> <li>Click the <b>RossTalk Device</b> button and select the device you want to send the RossTalk command to.</li> <li>Enter the take item id of the item you want to take in the <b>Take ID</b> field.</li> <li>Enter the framebuffer that you want to take the item on in the <b>Channel</b> field.</li> <li>Enter the layer that you want to take the item on in the <b>Layer</b> field.</li> </ol> |
| RossTalk — Take Off         | Devices > RossTalk   | Send the Take Off command for a specific item to the selected device. <ol style="list-style-type: none"> <li>Click <b>Take Offline</b>.</li> <li>Click the <b>RossTalk Device</b> button and select the device you want to send the RossTalk command to.</li> <li>Enter the take item id of the item you want to take in the <b>Take ID</b> field.</li> </ol>  |
| RState, Load                | Switcher > Load RState   | Load the custom reset settings for the selected area. <ol style="list-style-type: none"> <li>Click the <b>Include</b> button and select all the locations that you want to recall the custom reset settings on.</li> </ol>   |
| Source Substitution, Delete | Switcher Installation > Source Substitution > Delete Subst Table | Delete an entry from the substitution table. <ol style="list-style-type: none"> <li>Click the <b>Source</b> button and select the source that you want to delete the substitution(s) for. If more than one substitution entry exists for the selected source, all those entries will be deleted.</li> </ol>  |
| Source Substitution         | Switcher Installation > Source Substitution > Source ME Sub      | Set a source substitution for the substitution table. <ol style="list-style-type: none"> <li>Click the <b>Source</b> button and select the source that you want to set a substitution for.</li> <li>Click the <b>ME</b> button and select the MiniME™ that you want to assign a substitution source to.</li> <li>Click the <b>Subst</b> button and select the source you want to substitute for the selected source.</li> </ol>  |
| State, Insert               | Special > State  | Insert the current state of the switcher into the custom control. <ol style="list-style-type: none"> <li>Click <b>State Attributes</b> and select the elements that you want to include in the state of the switcher when it is stored to the custom control.</li> </ol>   |
| Switching Field             | Switcher Installation > Field Switch                             | Select the field that a video transition will be performed on. <ol style="list-style-type: none"> <li>Click a <b>Switch Field</b> button to select whether video transitions are performed on field 1 only (<b>Field 1</b>), field 2 only (<b>Field 2</b>), or the current field (<b>Both</b>).</li> </ol>   |
| Trans Clear                 | Switcher > Transition > ME Trans Action                          | Configures the next transition area of the selected area to take all keys off-air with the next transition. <ol style="list-style-type: none"> <li>Click the <b>ME</b> button and select the area that you want to perform the event on.</li> <li>Click the <b>Action</b> button and select <b>Trans Clear</b>.</li> </ol>   |
| Trans Elements              | Switcher > Transition > ME Trans Elements                        | Select the elements to be included in the next transition of the selected area. <ol style="list-style-type: none"> <li>Click the <b>ME</b> button and select the area that you want to perform the event on.</li> <li>Click the <b>Elements</b> button and select background and/or the keys that you want to include in the next transition.</li> </ol>   |

| Event                   | Location  | Description   |
|-------------------------|---|---|
| Trans Limit — On/Off    | Switcher > Transition > ME<br>Trans Limit           | Turn the transition limit feature on or off for the selected area. <ol style="list-style-type: none"> <li>1. Click the <b>ME</b> button and select the area that you want to perform the event on.</li> <li>2. Click the <b>Change Type</b> button and select whether you want to set (<b>Absolute</b>) or reset (<b>Reset</b>) the parameter. Some selections will not be available when you reset the parameter.</li> <li>3. Click the <b>Value</b> button and select whether trans limit is on (<b>On</b>) or not (<b>Off</b>).</li> </ol>   |
| Trans Limit — Reset     | Switcher > Transition > ME<br>Trans Action          | Resets the transition limit point of the selected area. <ol style="list-style-type: none"> <li>1. Click the <b>ME</b> button and select the area that you want to perform the event on.</li> <li>2. Click the <b>Action</b> button and select <b>Reset Limit</b>.</li> </ol>  |
| Trans Limit — Set       | Switcher > Transition > ME<br>Trans Action          | Sets the transition limit point of the selected area. You must select the point in the transition that you want to place the limit before running this event. <ol style="list-style-type: none"> <li>1. Click the <b>ME</b> button and select the area that you want to perform the event on.</li> <li>2. Click the <b>Action</b> button and select <b>Set Limit</b>.</li> </ol>  |
| Trans Limit — Value     | Switcher > Transition > ME<br>Trans Limit Value     | Select the limit point for the trans limit of the selected area. <ol style="list-style-type: none"> <li>1. Click the <b>ME</b> button and select the area that you want to perform the event on.</li> <li>2. Click the <b>Change Type</b> button and select whether you want to set (<b>Absolute</b>) or reset (<b>Reset</b>) the parameter. Some selections will not be available when you reset the parameter.</li> <li>3. Enter the point in the transition that you want to place the trans limit in the <b>Value (%)</b> field.</li> </ol> |
| Video Mode              | Switcher Installation ><br>Reference > Video Format | Select the video format that the switcher will operate in. <ol style="list-style-type: none"> <li>1. Click the <b>Video Mode</b> button and select the video format for the switcher.</li> </ol>  |
| Video Server — Cue      | Devices > Video Server                              | Send the Cue command and name of clip to cue to the selected device. <ol style="list-style-type: none"> <li>1. Click <b>Cue</b>.</li> <li>2. Click the <b>Video Server</b> button and select the device you want to send the command to.</li> <li>3. Click a <b>Channel</b> button to select the channel you want to send the command to.</li> <li>4. Enter the identifier of the clip in the <b>Clip Name</b> field.</li> </ol>  |
| Video Server — Loop Off | Devices > Video Server                              | Send the Loop Off command to the selected device. <ol style="list-style-type: none"> <li>1. Click <b>Loop Off</b>.</li> <li>2. Click the <b>Video Server</b> button and select the device you want to send the command to.</li> <li>3. Click a <b>Channel</b> button to select the channel you want to send the command to.</li> </ol>  |
| Video Server — Loop On  | Devices > Video Server                              | Send the Loop On command to the selected device. <ol style="list-style-type: none"> <li>1. Click <b>Loop On</b>.</li> <li>2. Click the <b>Video Server</b> button and select the device you want to send the command to.</li> <li>3. Click a <b>Channel</b> button to select the channel you want to send the command to.</li> </ol>  |

| Event                    | Location                               | Description   |
|--------------------------|--|---|
| Video Server — Play      | Devices > Video Server                 | Send the Play command to the selected device.<br><ol style="list-style-type: none"> <li>1. Click <b>Play</b>.</li> <li>2. Click the <b>Video Server</b> button and select the device you want to send the command to.</li> <li>3. Click a <b>Channel</b> button to select the channel you want to send the command to.</li> </ol>   |
| Video Server — Record    | Devices > Video Server                 | Send the Record command to the selected device.<br><ol style="list-style-type: none"> <li>1. Click <b>Record</b>.</li> <li>2. Click the <b>Video Server</b> button and select the device you want to send the command to.</li> <li>3. Click a <b>Channel</b> button to select the channel you want to send the command to.</li> </ol>   |
| Video Server — Stop      | Devices > Video Server                 | Send the Stop command to the selected device.<br><ol style="list-style-type: none"> <li>1. Click <b>Play</b>.</li> <li>2. Click the <b>Video Server</b> button and select the device you want to send the command to.</li> <li>3. Click a <b>Channel</b> button to select the channel you want to send the command to.</li> </ol>   |
| Wash Color (HSL)         | Switcher > Matte > Wash Color (HSL)    | Select the custom matte color for the selected ME or aux. Each component of the HSL color must be inserted individually. This is the second color of the wash, the first color is set from the matte color.<br><ol style="list-style-type: none"> <li>1. Click the <b>ME</b> button for the ME that you want to perform the event on.</li> <li>2. Click the <b>Matte</b> button and select <b>Wash</b>.</li> <li>3. Click the <b>Change Type</b> button and select whether you want to set (<b>Absolute</b>) or reset (<b>Reset</b>) the parameter. Some selections will not be available when you reset the parameter.</li> <li>4. Click the <b>Component</b> button and select the HSL component you want to assign a value to. A value should be applied to all three components.</li> <li>5. Enter a value for the selected component in the <b>Value (%)</b> field.</li> </ol> |
| Wash Color (Preset)      | Switcher > Matte > Wash Color (Preset) | Select a preset wash color for the selected ME. This is the second color of the wash, the first color is set from the matte color.<br><ol style="list-style-type: none"> <li>1. Click the <b>ME</b> button for the ME that you want to perform the event on.</li> <li>2. Click the <b>Matte</b> button and select <b>Wash</b>.</li> <li>3. Click the <b>Color</b> button and select the color you want to use.</li> </ol>   |
| Wash Color Reset         | Switcher > Matte > Wash Color Reset    | Reset the matte color for the selected ME. This is the second color of the wash, the first color is set from the matte color.<br><ol style="list-style-type: none"> <li>1. Click the <b>ME</b> button for the ME that you want to perform the event on.</li> <li>2. Click the <b>Matte</b> button and select <b>Wash</b>.</li> </ol>  |
| Wash Generator — Disable | Switcher > Matte > Wash Enabled Reset  | Disable the wash generator for the selected ME.<br><ol style="list-style-type: none"> <li>1. Click the <b>ME</b> button for the ME that you want to perform the event on.</li> </ol>  |
| Wash Generator — Enable  | Switcher > Matte > Wash Enabled        | Enable the wash generator for the selected ME.<br><ol style="list-style-type: none"> <li>1. Click the <b>ME</b> button for the ME that you want to perform the event on.</li> <li>2. Click the <b>Wash</b> button and select whether the wash generator is enabled (<b>On</b>) or not (<b>Off</b>).</li> </ol>  |

| Event                                       | Location  | Description  |
|---|---|--|
| <b>Wipe Direction (Flip-Flop)</b>           | <b>Switcher &gt; Transition &gt; Wipe Direction</b>             | <p>Select whether the wipe reverses direction for every second transition of the selected ME.</p> <ol style="list-style-type: none"> <li>1. Click the <b>ME</b> button for the ME that you want to perform the event on.</li> <li>2. Click the <b>Pattern</b> button and select <b>Wipe</b>.</li> <li>3. Click the <b>Change Type</b> button and select whether you want to set (<b>Absolute</b>) or reset (<b>Reset</b>) the parameter. Some selections will not be available when you reset the parameter.</li> <li>4. Click the <b>Parameter</b> button and select <b>Flip-Flip</b>.</li> <li>5. Click the <b>Value</b> button and select whether Flip-Flop is on (<b>On</b>) or off (<b>Off</b>).</li> </ol>   |
| <b>Wipe Direction</b>                       | <b>Switcher &gt; Transition &gt; Wipe Direction</b>             | <p>Select the direction for the wipe transition of the selected ME.</p> <ol style="list-style-type: none"> <li>1. Click the <b>ME</b> button for the ME that you want to perform the event on.</li> <li>2. Click the <b>Pattern</b> button and select <b>Wipe</b>.</li> <li>3. Click the <b>Change Type</b> button and select whether you want to set (<b>Absolute</b>) or reset (<b>Reset</b>) the parameter. Some selections will not be available when you reset the parameter.</li> <li>4. Click the <b>Parameter</b> button and select <b>Direction</b>.</li> <li>5. Click the <b>Value</b> button and select whether the wipe moves in a forward (<b>Forward</b>) or reverse (<b>Reverse</b>) direction.</li> </ol>  |
| <b>Wipe Pattern — Aspect Ratio</b>          | <b>Switcher &gt; Transition &gt; Wipe Param</b>                 | <p>Select the aspect ratio for the wipe pattern you want to use for a wipe transition of the selected ME.</p> <ol style="list-style-type: none"> <li>1. Click the <b>ME</b> button for the ME that you want to perform the event on.</li> <li>2. Click the <b>Parameter</b> button and select <b>Aspect</b>.</li> <li>3. Click the <b>Change Type</b> button and select whether you want to set (<b>Absolute</b>) or reset (<b>Reset</b>) the parameter. Some selections will not be available when you reset the parameter.</li> <li>4. Enter an aspect ratio in the <b>Value (%)</b> field.</li> </ol>   |
| <b>Wipe Pattern — Border Color (HSL)</b>    | <b>Switcher &gt; Transition &gt; Wipe Border Color (HSL)</b>    | <p>Select the custom color you want to apply to the border of the pattern for the wipe transition of the selected ME. Each component of the HSL color must be inserted individually.</p> <ol style="list-style-type: none"> <li>1. Click the <b>ME</b> button for the ME that you want to perform the event on.</li> <li>2. Click the <b>Matte</b> button and select <b>Wipe Border</b>.</li> <li>3. Click the <b>Change Type</b> button and select whether you want to set (<b>Absolute</b>) or reset (<b>Reset</b>) the parameter. Some selections will not be available when you reset the parameter.</li> <li>4. Click the <b>Component</b> button and select the HSL component you want to assign a value to. A value should be applied to all three components.</li> <li>5. Enter a value for the selected component in the <b>Value (%)</b> field.</li> </ol> |
| <b>Wipe Pattern — Border Color (Preset)</b> | <b>Switcher &gt; Transition &gt; Wipe Border Color (Preset)</b> | <p>Select the preset color you want to apply to the border of the pattern for the wipe transition of the selected ME.</p> <ol style="list-style-type: none"> <li>1. Click the <b>ME</b> button for the ME that you want to perform the event on.</li> <li>2. Click the <b>Matte</b> button and select <b>Wipe Border</b>.</li> <li>3. Click the <b>Color</b> button and select the preset color you want to apply to the border.</li> </ol>  |

| Event                                    | Location                            | Description  |
|--|-------------------------------------|--|
| Wipe Pattern — Border Size               | Switcher > Transition > Wipe Param  | <p>Select the size of border for the wipe pattern you want to use for a wipe transition of the selected ME.</p> <ol style="list-style-type: none"> <li>1. Click the <b>ME</b> button for the ME that you want to perform the event on.</li> <li>2. Click the <b>Parameter</b> button and select <b>Border Size</b>.</li> <li>3. Click the <b>Change Type</b> button and select whether you want to set (<b>Absolute</b>) or reset (<b>Reset</b>) the parameter. Some selections will not be available when you reset the parameter.</li> <li>4. Enter a size for the border in the <b>Value (%)</b> field.</li> </ol>  |
| Wipe Pattern — Edge Softness             | Switcher > Transition > Wipe Param  | <p>Select the amount of softness to apply to the edge of the pattern or border for the wipe pattern you want to use for a wipe transition of the selected ME.</p> <ol style="list-style-type: none"> <li>1. Click the <b>ME</b> button for the ME that you want to perform the event on.</li> <li>2. Click the <b>Parameter</b> button and select <b>Softness</b>.</li> <li>3. Click the <b>Change Type</b> button and select whether you want to set (<b>Absolute</b>) or reset (<b>Reset</b>) the parameter. Some selections will not be available when you reset the parameter.</li> <li>4. Enter an amount of softness for the pattern or border in the <b>Value (%)</b> field.</li> </ol> |
| Wipe Pattern — Horizontal Multiplication | Switcher > Transition > Wipe Param  | <p>Select the number of times you want to multiply the wipe pattern horizontally for the wipe transition of the selected ME.</p> <ol style="list-style-type: none"> <li>1. Click the <b>ME</b> button for the ME that you want to perform the event on.</li> <li>2. Click the <b>Parameter</b> button and select <b>Horizontal Mult</b>.</li> <li>3. Click the <b>Change Type</b> button and select whether you want to set (<b>Absolute</b>) or reset (<b>Reset</b>) the parameter. Some selections will not be available when you reset the parameter.</li> <li>4. Enter the number of times the pattern is multiplied in the <b>Value</b> field.</li> </ol>                                 |
| Wipe Pattern — Pattern                   | Switcher > Transition > Wipe Effect | <p>Select the pattern you want to use for a wipe transition of the selected ME.</p> <ol style="list-style-type: none"> <li>1. Click the <b>ME</b> button for the ME that you want to perform the event on.</li> <li>2. Click the <b>Pattern</b> button and select the pattern you want to use for the wipe.</li> </ol>   |
| Wipe Pattern — Rotation                  | Switcher > Transition > Wipe Param  | <p>Select the rotation for the wipe pattern you want to use for a wipe transition of the selected ME.</p> <ol style="list-style-type: none"> <li>1. Click the <b>ME</b> button for the ME that you want to perform the event on.</li> <li>2. Click the <b>Parameter</b> button and select <b>Rotation</b>.</li> <li>3. Click the <b>Change Type</b> button and select whether you want to set (<b>Absolute</b>) or reset (<b>Reset</b>) the parameter. Some selections will not be available when you reset the parameter.</li> <li>4. Enter a rotation in the <b>Value (%)</b> field.</li> </ol>  |
| Wipe Pattern — Size                      | Switcher > Transition > Wipe Param  | <p>Select the size for the wipe pattern you want to use for a wipe transition of the selected ME.</p> <ol style="list-style-type: none"> <li>1. Click the <b>ME</b> button for the ME that you want to perform the event on.</li> <li>2. Click the <b>Parameter</b> button and select <b>Size</b>.</li> <li>3. Click the <b>Change Type</b> button and select whether you want to set (<b>Absolute</b>) or reset (<b>Reset</b>) the parameter. Some selections will not be available when you reset the parameter.</li> <li>4. Enter a new size in the <b>Value (%)</b> field.</li> </ol>  |

| Event   | Location  | Description  |
|---|---|--|
| <b>Wipe Pattern — Vertical Multiplication</b> | <b>Switcher &gt; Transition &gt; Wipe Param</b> | <p>Select the number of times you want to multiply the wipe pattern vertically for the wipe transition of the selected ME.</p> <ol style="list-style-type: none"> <li>1. Click the <b>ME</b> button for the ME that you want to perform the event on.</li> <li>2. Click the <b>Parameter</b> button and select <b>Vertical Mult.</b></li> <li>3. Click the <b>Change Type</b> button and select whether you want to set (<b>Absolute</b>) or reset (<b>Reset</b>) the parameter. Some selections will not be available when you reset the parameter.</li> <li>4. Enter the number of times the pattern is multiplied in the <b>Value</b> field.</li> </ol> |
| <b>Wipe Pattern — X-Position</b>              | <b>Switcher &gt; Transition &gt; Wipe Param</b> | <p>Select the x-axis position for the wipe pattern you want to use for a wipe transition of the selected ME.</p> <ol style="list-style-type: none"> <li>1. Click the <b>ME</b> button for the ME that you want to perform the event on.</li> <li>2. Click the <b>Parameter</b> button and select <b>X-Pos.</b></li> <li>3. Click the <b>Change Type</b> button and select whether you want to set (<b>Absolute</b>) or reset (<b>Reset</b>) the parameter. Some selections will not be available when you reset the parameter.</li> <li>4. Enter a new position in the <b>Value (%)</b> field.</li> </ol>  |
| <b>Wipe Pattern — Y-Position</b>              | <b>Switcher &gt; Transition &gt; Wipe Param</b> | <p>Select the y-axis position for the wipe pattern you want to use for a wipe transition of the selected ME.</p> <ol style="list-style-type: none"> <li>1. Click the <b>ME</b> button for the ME that you want to perform the event on.</li> <li>2. Click the <b>Parameter</b> button and select <b>Y-Pos.</b></li> <li>3. Click the <b>Change Type</b> button and select whether you want to set (<b>Absolute</b>) or reset (<b>Reset</b>) the parameter. Some selections will not be available when you reset the parameter.</li> <li>4. Enter a new position in the <b>Value (%)</b> field.</li> </ol>  |
| <b>Wipe Reset</b>                             | <b>Switcher &gt; Transition &gt; Wipe Reset</b> | <p>Reset the parameters or direction and flip-flop for the wipe transition of the selected ME.</p> <ol style="list-style-type: none"> <li>1. Click the <b>ME</b> button for the ME that you want to perform the event on.</li> <li>2. Click <b>Reset Params</b> to reset the wipe parameters or <b>Reset Direction</b> to reset the wipe direction and flip-flop.</li> </ol>   |

---

# Glossary

## Interlaced

An Interlaced video format starts at the top of the screen and draws all the odd number scan lines and then all the even number scan lines in sequence. This results in half the image being drawn in one pass and the other half of the image being drawn in the second. These two passes are called Fields, where the first pass is called Field 1 and the second pass is called Field 2. When both Field 1 and Field 2 have been drawn, resulting in a complete image, you have a single Frame.

## Progressive

A Progressive scan video format draws each scan line in sequence, starting from the top of the screen and working to the bottom. Unlike Interlaced, with Progressive scan the entire image is drawn at one time, in a single pass. This means that there are no fields in a Progressive scan image.

## Auto Key

A pairing of two video signals, a key video and a key alpha, to create a key. In the switcher, you associate the fill and alpha so that the switcher knows which alpha to use when the video is selected.

## Auto Transition

An automatic transition in which the manual movement of the fader handle is simulated electronically. The transition starts when the **AUTO TRANS** button is pressed and takes place over a pre-selected time period, measured in frames.

## Chroma Key

Chroma Key is a key in which the hole is cut based on a color value, or hue, rather than a luminance value or alpha signal. The color is removed and replaced with background video from another source.

## Cut

An instantaneous switch from one video signal to another.

## Dissolve

A transition from one video signal to another in which one signal is faded down, while the other is simultaneously faded up. The terms mix or cross-fade are often used interchangeably with dissolve.

## Field

One half of a complete picture (or frame) interval containing all of the odd, or all of the even, lines in interlaced scanning. One scan of a TV screen is called a field; two fields are required to make a complete picture (which is a frame).

## Force, Mask

An effect that forces the masked region to the foreground but is not bound by the key. For example, if you have a key and apply a mask to it. The masked area is bound by the edges of the key. When force is turned on, the masked area is filled with the video from the key (nothing appears masked) but you can move the mask outside of the key and the key video is still filling the masked region.

## Frame

One complete picture consisting of two fields of interlaced scanning lines.

## File Transfer Protocol

A network protocol that is used to transfer files from one host computer to another over a TCP-based network.

## Gain

Gain represents the range of signal values present in a video signal from a lowest to a highest point (from black to white for example). Increasing gain expands this range, while decreasing gain compresses this range. Clipping occurs if applied gain changes cause output signal values to fall outside the allowable range. Generally, increasing the gain for a specific color component causes the video signal colors to become increasingly saturated with that color. Similarly, decreasing the gain for a specific color component progressively removes that color component from the output video signal.

## Gamma

Gamma corrections introduce non-linear corrections to a video signal. A gamma



---

correction can be described as taking a point on the output versus input video signal line and pulling it perpendicularly away from the line. The result is a Bezier curve between the start, the new point, and the end point. Generally, increasing the gamma value adds more of the component to the video signal in the location of the gamma offset point. Decreasing the gamma value reduces the amount of the component in the video signal in the location of the gamma offset point. Moving the gamma offset point allows you to select which part of the input video signal receives the gamma correction. For example, if you increase the red gamma correction to the part of the video signal that has no red component you will add red to those areas while having little effect on areas that already contain a significant amount of red. This allows you to add a red tint to the image while minimizing the amount of red-clipping that occurs.

### General Purpose Interface

A simple high/low signal that is used to trigger an action either on an external device or on the switcher. A GPI can be an input or an output to the switcher.

### High Definition

A high definition (720p, 1080i, or 1080p/3G) video signal.

### Hue

The characteristic of a color signal that determines whether the color is red, yellow, green, blue, purple, etc. (the three characteristics of a TV color signal are chrominance, luminance, and hue). White, black, and gray are not considered hues.

### Hue Rotation

Hue rotate affects the color of the entire video signal by rotating the input video hues. This produces an output video signal with colors that are shifted from their original hues. By rotating colors around the wheel, hue values will shift. For example, a clockwise rotation where yellows become orange, reds become magenta, blues become green. The more rotation applied, the further around the wheel colors are shifted.

### Key

An effect produced by cutting a hole in the background video, then filling the hole with video or matte from another source. Key source video cuts the hole, key fill video fills the hole. The video signal used for cut and fill can come from the same, or separate, sources.

### Key Alpha

The video signal which cuts a hole in the background video to make a key effect possible. Also called Key Video or Source. In practice, this signal controls when a video mixer circuit will switch from background to key fill video.

### Key Invert

An effect that reverses the polarity of the key source so that the holes in the background are cut by dark areas of the key source instead of bright areas.

### Key Mask

A keying technique in which a shape is combined with the key source to block out unwanted portions of the key source.

### Key Video

A video input which is timed to fill the hole provided by the key source video. An example of key video is the video output of a character generator.

### Linear Key

Linear keys make it possible to fully specify the transparency of a key from opaque, through transparent, to fully off. The transparency is specified by the key alpha that is associated with the key video. A keyer capable of a linear key converts the key signal voltage directly to the transparency effect on the screen.

### Mnemonics

A green, orange, or yellow display used to show the names of a source above or below the source button or used as a custom command or pattern button.

### Offsets

Offsets shift the video signal by a set amount. Depending on the offset applied, different parts or all of the video signal may be affected. Clipping occurs if applied offsets cause output signal values to fall outside the allowable range.

---

## Pre-Delay

A pre-delay is a delay that is inserted into a transition between the triggering of a GPI output and performing the transition. The length of the pre-delay is usually the length of time your video server requires to start playing a clip or your character generator required to load a page.

## RossTalk

An ethernet based protocol that allows the control over Ross devices using plain english commands.

## Standard-Definition

A standard definition (480i or 576i) video signal.

## Self Key

A key effect in which the same video signal serves as both the key signal and key fill.

## Shaped Key

An additive key where the Key Alpha cuts a hole based on the monochrome value of the alpha. Shades of gray are translated into either white or black, giving the key a hard edge. Shaped Key alphas are sometimes used with Character Generators to cut very precise holes for the fill.

## Split Key

A Split key allows you to assign a different alpha source for a key than the fill/alpha associations that are set up during configuration or to use a separate alpha source for a Self key.

## Tally

An indicator which illuminates when the associated button, or control, is selected or is on-air.

## Unshaped Key

A multiplicative key where the Key Alpha cuts a hole based on the gradient values of the alpha. Shades of gray are translated into transparency levels, giving the key a soft edge. Unshaped Key alphas can also be considered true linear alphas.

---

# Index

## A

- AES Out [82](#)
- AES Output [82](#)
- Allocated DVEs [99](#)
- Ancillary Data [70](#)
- Ancillary Mode [99](#)
- Animations [51](#)
- Aspect Ratio [80](#)
- Aspect Ratio Conversion [79](#)
  - Full [79](#)
  - Letterbox [80](#)
  - Pillarbox [80](#)
  - Zoom [80](#)
- Audio [51](#)
- Audio Out [82](#)
- Auto Follow [67](#)
  - Custom Pages [67](#)
- Auto Key [66](#)
- Auto Select Keys [35](#)
- Auto Transition [28–30](#)
- Aux Bus [20](#)
  - Source Selection [20](#)

## B

- BG Source [24](#)
- Bus Hold [44](#)
- Bus Map, Default [101](#)
- Bus Maps [87](#)
- Bus Select Buttons, ViewControl [95](#)

## C

- Canvas [20](#)
  - Source Selection [20](#)
- Capture [53](#)
- CC, *See* Custom Controls
- CC Pause [55](#)
- Chroma Key [36–37](#)
  - Advanced Mode [37](#)
  - Basic Mode [36](#)
- Chroma Key Modes [36](#)
- Clean Feed [22, 71](#)
  - Layer Mode [71](#)
- Clear Custom Controls [101](#)
- Clear Memories [101](#)
- Color Background [24](#)
- Color Correction [83](#)
  - Proc Amp [83](#)
  - RGB [83](#)
- Color Schemes [86](#)
- Color Temperature [83](#)
- Colors, Memory Recall [45](#)
- Copy Keys [25](#)
- Copy Logs [99](#)

- Copy MEs [25](#)
- CPU Temperature [99](#)
- Custom Control Buttons, ViewControl [95](#)
- Custom Control Event [106, 116](#)
  - Ancillary Data Mode [106](#)
  - Audio Pan [106](#)
  - Audio Volume [106](#)
  - Auto Trans [106](#)
  - Bus Source [106](#)
  - Cancel All CC [106](#)
  - Cancel CC [106](#)
  - Chroma Key Color [107](#)
  - Chroma Key Initialize [106](#)
  - Chroma Key Mode [107](#)
  - Chroma Key Parameters [107](#)
  - Clean Feed [107](#)
  - Color Framing [107](#)
  - Cut Transition [107](#)
  - DVE Freeze [107](#)
  - DVE Key Aspect [108](#)
  - DVE Key Border [108](#)
  - DVE Key Border Color (HSL) [108](#)
  - DVE Key Border Color (Preset) [108](#)
  - DVE Key Crop (Bottom Edge) [109](#)
  - DVE Key Crop (Dual Edge) [109](#)
  - DVE Key Crop (Left Edge) [109](#)
  - DVE Key Crop (Right Edge) [109](#)
  - DVE Key Crop (Top Edge) [110](#)
  - DVE Key Edge Softness [110](#)
  - DVE Key Size [110](#)
  - DVE Key X-Position [110](#)
  - DVE Key Y-Position [111](#)
  - DVE Wipe Direction [111](#)
  - DVE Wipe Direction (Flip-Flop) [111](#)
  - DVE Wipe Pattern [111](#)
  - DVE Wipe, Reset [111](#)
  - EmbeddedTriggers — Enable [111](#)
  - EmbeddedTriggers — Insert [112](#)
  - EmbeddedTriggers — Set DID [112](#)
  - EmbeddedTriggers — Set Line [112](#)
  - EmbeddedTriggers — Set Remote ID [112](#)
  - EmbeddedTriggers — Set SDID [112](#)
  - Fly Key (DVE) [112](#)
  - GPI Output — Edge Trigger Setup [112](#)
  - GPI Output — Level Trigger Setup [113](#)
  - GPI Output — Mode [113](#)
  - GPI Output — Trigger [113](#)
  - GPI Output — Trigger Type [113](#)
  - Hold CC [113](#)
  - Key Active [113](#)
  - Key Copy [114](#)
  - Key Invert [114](#)
  - Key Mode [114](#)
  - Key Only Transition [114](#)
  - Key Settings (Clip, Gain, Transparency) [114](#)
  - Key Trans Rate [115](#)
  - Key Type [115](#)

---

Custom Control Event (*continued*)

- Key, Make Linear [113](#)
- Key, Reset [114](#)
- Layer Mode [115](#)
- Loop CC [115](#)
- Mask [120](#)
- Mask (Box) — Left Edge Position [116](#)
- Mask (Box) — Right Edge Position [117](#)
- Mask (Box) — Size [117](#)
- Mask (Box) — Top Edge Position [117](#)
- Mask (Box) — X-Position [117](#)
- Mask (Box) — Y-Position [118](#)
- Mask (Pattern) — Aspect Ratio [118](#)
- Mask (Pattern) — Border Size [118](#)
- Mask (Pattern) — Edge Softness [118](#)
- Mask (Pattern) — Horizontal Multiplication [118](#)
- Mask (Pattern) — Pattern [118](#)
- Mask (Pattern) — Reset [119](#)
- Mask (Pattern) — Rotation [119](#)
- Mask (Pattern) — Size [119](#)
- Mask (Pattern) — Vertical Multiplication [119](#)
- Mask (Pattern) — X-Position [119](#)
- Mask (Pattern) — Y-Position [119](#)
- Mask, Force [115](#)
- Mask, Invert [116](#)
- Mask, Reset [116](#)
- Matte Color (HSL) [120](#)
- Matte Color (Preset) [120](#)
- Matte Color, Reset [120](#)
- ME Copy [120](#)
- ME Trans Rate [125](#)
- ME Trans Type [125](#)
- Media Cut Point, Set [124](#)
- Media Trans End Point, Set [124](#)
- Media Trans Start Point, Set [124](#)
- Media Trans Thumbnail [124](#)
- Media-Store — Auto Play [120](#)
- Media-Store — Capture [121](#)
- Media-Store — Capture Alpha [120](#)
- Media-Store — Capture Mode [121](#)
- Media-Store — Capture Source [121](#)
- Media-Store — Clear Channel [121](#)
- Media-Store — Cut Frame [121](#)
- Media-Store — Delete Capture [121](#)
- Media-Store — Load [121](#)
- Media-Store — Looping [121](#)
- Media-Store — Move To Frame [122](#)
- Media-Store — Mute [122](#)
- Media-Store — Play [122](#)
- Media-Store — Play Speed [122](#)
- Media-Store — Reset Media [122](#)
- Media-Store — Reverse [122](#)
- Media-Store — Rewind [122](#)
- Media-Store — Shaped [123](#)
- Media-Store — Trigger GPI Output Delay [123](#)
- Media-Store — Trigger GPI Output [123](#)
- Media-Store — X-Position [123](#)
- Media-Store — Y-Position [123](#)
- MediaWipe — Channel [123](#)
- MediaWipe — Direction [124](#)
- MediaWipe — Direction, Flip-Flop [124](#)

Custom Control Event (*continued*)

- MediaWipe — Layer [124](#)
- Memory Recall [125](#)
- MultiScreen — Edge Blending [125](#)
- MultiScreen — Edge Distance [125](#)
- MultiScreen — Edge Gamma [126](#)
- MultiScreen — Edge Smoothness [126](#)
- MultiScreen — Layout [126](#)
- MultiScreen — Offset [126](#)
- MultiViewer — Clip [128](#)
- MultiViewer — FSFC Label [130](#)
- MultiViewer — Layout [130](#)
- MultiViewer — Outputs [130](#)
- MultiViewer — Tally Display [130](#)
- MultiViewer Box — Aspect Ratio Markers [126](#)
- MultiViewer Box — Border [127](#)
- MultiViewer Box — Green Tally (Preview) [127](#)
- MultiViewer Box — Label [127](#)
- MultiViewer Box — Label Mode [127](#)
- MultiViewer Box — Label Position [127](#)
- MultiViewer Box — Label Transparency [128](#)
- MultiViewer Box — MultiScreen Markers [128](#)
- MultiViewer Box — Red Tally (On-Air) [128](#)
- MultiViewer Box — Video Source [128](#)
- MultiViewer Clock — Background Color (HSL) [130](#)
- MultiViewer Clock — Background Color (Preset) [128](#)
- MultiViewer Clock — Foreground Color (HSL) [129](#)
- MultiViewer Clock — Foreground Color (Preset) [129](#)
- MultiViewer Clock — Format [129](#)
- MultiViewer Clock — Mode [129](#)
- MultiViewer Clock — Size [129](#)
- MultiViewer Clock — Timecode Frame Count [129](#)
- MultiViewer Clock — X-Position [130](#)
- Output BNC Assignment [131](#)
- Pause CC [131](#)
- PBus — Recall [131](#)
- PBus — Trigger [131](#)
- Personality — Auto Remove Key [131](#)
- Personality — Auto Trans Second Press (Key) [131](#)
- Personality — Auto Trans Second Press (ME) [132](#)
- Personality — Next Trans Reset [132](#)
- Personality — Roll Clip [132](#)
- Play CC [132](#)
- Reference Source [132](#)
- Reset [132](#)
- Resume CC [132](#)
- Robotic Camera — Halt All [132](#)
- Robotic Camera — Recall Shot [133](#)
- Robotic Camera — Recall Shot Fast [133](#)
- Robotic Camera — Store Shot [133](#)
- Roll Clip [133](#)
- RossTalk — CC [133](#)
- RossTalk — Clear [133](#)
- RossTalk — Cue (item + framebuffer + layer) [134](#)
- RossTalk — Cue (item + framebuffer) [134](#)
- RossTalk — Cue Current [134](#)
- RossTalk — Focus [134](#)
- RossTalk — GPI [134](#)
- RossTalk — Next [134](#)
- RossTalk — Read [135](#)
- RossTalk — Resume [135](#)

---

Custom Control Event (*continued*)

- RossTalk — Sequencer Down [135](#)
- RossTalk — Sequencer Up [135](#)
- RossTalk — Swap [135](#)
- RossTalk — Swap Current [135](#)
- RossTalk — Take [136](#)
- RossTalk — Take Current [135](#)
- RossTalk — Take Off [136](#)
- RossTalk Custom Command [134](#)
- RState, Load [136](#)
- Source Substitution [136](#)
- Source Substitution, Delete [136](#)
- State, Insert [136](#)
- Switching Field [136](#)
- Trans Clear [136](#)
- Trans Elements [136](#)
- Trans Limit — On/Off [137](#)
- Trans Limit — Reset [137](#)
- Trans Limit — Set [137](#)
- Trans Limit — Value [137](#)
- Video Mode [137](#)
- Video Server — Cue [137](#)
- Video Server — Loop Off [137](#)
- Video Server — Loop On [137](#)
- Video Server — Play [138](#)
- Video Server — Record [138](#)
- Video Server — Stop [138](#)
- Wash Color (HSL) [138](#)
- Wash Color (Preset) [138](#)
- Wash Color Reset [138](#)
- Wash Generator — Disable [138](#)
- Wash Generator — Enable [138](#)
- Wipe Direction [139](#)
- Wipe Direction (Flip-Flop) [139](#)
- Wipe Pattern — Aspect Ratio [139](#)
- Wipe Pattern — Border Color (HSL) [139](#)
- Wipe Pattern — Border Color (Preset) [139](#)
- Wipe Pattern — Border Size [140](#)
- Wipe Pattern — Edge Softness [140](#)
- Wipe Pattern — Horizontal Multiplication [140](#)
- Wipe Pattern — Pattern [140](#)
- Wipe Pattern — Rotation [140](#)
- Wipe Pattern — Size [140](#)
- Wipe Pattern — Vertical Multiplication [141](#)
- Wipe Pattern — X-Position [141](#)
- Wipe Pattern — Y-Position [141](#)
- Wipe Reset [141](#)

Custom Controls [15](#), [55–57](#), [106](#)

- CC Pause [55](#)
- Copy/Paste [57](#)
- DashBoard [15](#)
- Deleting [57](#)
- Editing [55](#)
- Events [106](#)
- Naming [56](#)
- Recording [55](#)
- Run Event [55](#)
- Running [56](#)

Custom Controls, Default [101](#)

Custom Pages [67](#)

- Auto Follow [67](#)

Cut Transition [28–30](#)

Cut Transitions [31](#)

## D

DashBoard [15–17](#)

- Configuration [15](#)
- Custom Controls [15](#)
- Live Assist [15](#)
- MediaManager [16](#)
- Panel [17](#)
- PaneLINK [15](#)
- Personality [16](#)
- Status [15](#)
- ViewControl [15](#)

Date, System Time [81](#)

Default [101](#)

- Factory [101](#)

Default Bus Map [101](#)

Delete Media Item [51](#)

Delete Memory [47](#)

Deleting a Still [51](#)

Device Control [12](#)

Diagnostics [99](#)

- Copy Logs [99](#)

DIP Switches [99](#)

Dissolve Transitions [31](#)

DVE [40–41](#)

- Cropping [41](#)
- Key [40–41](#)

DVE Freeze [41](#)

DVE Transitions [32](#)

## E

EDL [92](#)

Eject Media Item [51](#)

Engine Type [99](#)

Ethernet [58](#)

External Reference [99](#)

## F

Factory Default [101](#)

Fade to Black [89](#)

Field Dominance [99](#)

FlexiClean [22](#), [71](#)

Fly Key [40](#)

Follows, ME [71](#)

Format Conversion [78](#)

FPGA Temperature [99](#)

Frame Setup, Ethernet [58](#)

Frame Synchronizer [78](#)

Freeze [41](#)

FSFC [78–79](#)

- Input [79](#)
- QuadFS [79](#)
- SDI-FS [79](#)

FTP Connection [59](#)

---

## G

- Glow [86](#)
- GPI [66, 89](#)
  - Assign to Source [66](#)
  - Setup [89](#)
- GPO Tally [90](#)

## H

- Help [16](#)

## I

- Input FSFC [79](#)

## K

- Key RATE [31](#)
- Key Swap [25](#)
- Keyer Transition Buttons, ViewControl [95](#)
- Keying [35–37, 40–43](#)
  - Auto Select [35](#)
  - Chroma Key [36](#)
  - Chroma Key, Advanced [37](#)
  - Chroma Key, Basic [36](#)
  - DVE [40–41](#)
  - Key Priority [35](#)
  - Mask [42](#)
  - Self Key [35](#)
  - Split [35](#)
  - Split Keys [43](#)
- Keys [25](#)
  - Copy [25](#)

## L

- Layer Mode [71](#)
- Live Assist [15, 67](#)
  - Custom Pages [67](#)
  - PaneLINK [15](#)
- LiveEDL [92–93](#)
  - Capture [93](#)
  - Store [93](#)

## M

- Mask [42](#)
- Matte [24](#)
- ME [20](#)
  - Source Selection [20](#)
- ME Copying [25](#)
- ME Follows [68, 71](#)
  - Substitution Table [68](#)
- Media Transitions [33](#)
- Media-Store [51–53](#)
  - Animations [51](#)
  - Audio [51](#)
  - Capture [53](#)

## Media-Store (continued)

- Clear Channel [51](#)
- Delete Database Entry [51](#)
- Eject [51](#)
- File Specifications [52](#)
- Loading [52](#)
- MediaManager [16](#)
  - DashBoard [16](#)
- Memories [44–47](#)
  - As Stored Attribute [45](#)
  - Attributes [46](#)
  - Bus Hold [44](#)
  - Delete [47](#)
  - No Recall Attribute [45](#)
  - Recall Attribute [45](#)
  - Recall Colors [45](#)
  - Storing [44](#)
- Memories, Default [101](#)
- Memory Names [47](#)
- MiniME [13, 20, 26, 76](#)
  - Assignment [76](#)
  - Source Selection [20](#)
  - Transitions [26](#)
- MiniME Chroma Key [40](#)
- Mnemonic Source Names [64](#)
- Mnemonics [47, 65](#)
  - Memory [47](#)
- MultiPanel [98](#)
- MultiScreen [68, 76](#)
  - MiniME Assignment [76](#)
  - Substitution Table [68](#)
- MultiViewer [23, 73](#)
  - Ancillary Source [73](#)
  - Embedded Audio [73](#)
  - Formats [73](#)
  - Time-Clock [73](#)

## N

- Network Connection [58](#)
- Network Ports [58, 103](#)
- Next Trans Buttons [28–30](#)

## O

- On-Air Setting [72](#)
- Output Synchronizer [61](#)
- Outputs [69](#)
  - Video [69](#)

## P

- PanelBuilder [96](#)
- PaneLINK [15](#)
- Personality [16, 85](#)
  - DashBoard [16](#)
- Ports, Network [103](#)
- Pre-Tiled Sources [68](#)
- Preview [23](#)
- Preview, Transitions [28–30](#)

---

Proc Amp [83](#)

## Q

QuadFS [79](#)

## R

Rate, Transition [26](#)

Re-Entry [21](#)

Re-Entry Timing [21](#)

Real-Time Clock, System [81](#)

Reference [60–61](#)

External [60](#)

Internal [60](#)

Output Sync [61](#)

Video Switching Field [61](#)

Reference OK [99](#)

Reference Source [99](#)

Reset [101](#)

Custom [101](#)

RGB [83](#)

RGB Color Correctors [83](#)

ROLL CLIP [28–30](#)

RossLinq [59](#)

RossTalk Port [99](#)

RState [101](#)

RState, Save [101](#)

## S

Save Custom Reset [101](#)

SDI-FS [79](#)

Self Key [35](#)

Serial Number [99](#)

Sets [49](#)

Loading [49](#)

Storing [49](#)

Show Alpha [35–38](#), [41–42](#)

SoftPanel [17–18](#)

Bus Area [18](#)

Control Area [17](#)

Menu Area [17](#)

User Area [17](#)

Software Version [99](#)

Source Names [64](#)

Sources [21](#)

Layering [21](#)

Re-Entry [21](#)

Specifications [103–105](#)

AES [105](#)

GPI I/O [103](#)

LTC [105](#)

Serial Port [103](#)

Tally [104](#)

Split Key [43](#)

Split Keys [35](#)

Status [99](#)

Storing Memories [44](#)

Substitution Table [68](#)

MultiScreen [68](#)

Substitution Tables [68](#)

Switcher Mode [62](#)

Switcher Status [99](#)

Switching Field [61](#)

System Real-Time Clock [81](#)

## T

Tallies [67](#), [90](#)

GPO [90](#)

Temperature OK [99](#)

Time-Clock [73](#)

Timecode [92](#), [99](#)

Timing Windows, Re-Entry [21](#)

Trans Preview [28–30](#)

Transition Buttons, ViewControl [95](#)

Transitions [26](#), [28–33](#), [90](#)

Auto Transition [28–30](#)

Cut [28–30](#)

Cuts [31](#)

Direction [26](#)

Dissolves [31](#)

DVE [32](#)

Flip Flop [26](#)

from Panel [28–30](#)

from Touchscreen Menu [26](#)

GPO Trigger [90](#)

Media [33](#)

MiniME [26](#)

Pause [26](#)

Preview [28–30](#)

Rate [26](#)

Roll Clip [26](#)

Trans Preview [26](#)

Whiteflash [31](#)

Wipes [32](#)

Transitions Limit [26](#)

Trigger GPO [90](#)

TSL UMD [64](#)

TSL UMD Port [99](#)

## U

User Buttons [87–88](#)

## V

Video Input Type [64](#)

Video Inputs [63–64](#), [66](#)

Auto Key [66](#)

GPI Device Control [66](#)

Names [64](#)

Video Layering [21](#)

Video Mode [60](#), [99](#)

Setup [60](#)

Video Output [70–71](#), [73](#)

Ancillary Data [70](#)

Clean Feed [71](#)



---

Video Output (*continued*)

MultiViewer [73](#)

Video Outputs [69](#)

Video Processing and Flow [19](#)

Video Source [20](#), [87](#)

Bus Map [87](#)

Video Sources [20](#)

External [20](#)

Follows [20](#)

Internal [20](#)

Selecting [20](#)

Selecting on DashBoard [20](#)

ViewControl [15](#), [95](#)

Bus Selection Buttons [95](#)

Button Setup [95](#)

Custom Control Buttons [95](#)

Keyer Transition Buttons [95](#)

Transition Buttons [95](#)

## **W**

Whiteflash [31](#)

WhiteFlash [31](#)

Wipe Transitions [32](#)